

Investigations on resting site preferences by the tsetse fly *Glossina pallidipes* (Diptera, Glossinidae) as a means of improving the efficacy of visual baits for tsetse population control

**Emmanuel Kamba Mebourou**

Pr. Patrick Guerin, University of Neuchâtel, Neuchâtel, Suisse (Directeur de thèse)

Dr. Betty Benrey, Université de Neuchâtel, Neuchâtel, Suisse

Pr. Pierre Jay-Robert, Université Paul-Valéry, Montpellier, France



(© O. Esnault, cirad.fr)

Université de Neuchâtel

2016



## IMPRIMATUR POUR THESE DE DOCTORAT

---

La Faculté des sciences de l'Université de Neuchâtel  
autorise l'impression de la présente thèse soutenue par

**Monsieur Emmanuel KAMBA MEBOUROU**

Titre:

**“Investigations on resting site preferences by the  
tsetse fly *Glossina pallidipes* (Diptera, Glossinidae)  
as a means of improving the efficacy of visual baits  
for tsetse population control”**

sur le rapport des membres du jury composé comme suit:

- Prof. Patrick Guerin, directeur de thèse, Université de Neuchâtel, Suisse
- Dr Betty Benrey, Université de Neuchâtel, Suisse
- Prof. Pierre Jay-Robert, Université Paul-Valéry, Montpellier, France

Neuchâtel, le 16 janvier 2017

Le Doyen, Prof. R. Bshary





# Contents

<b>Contents</b> .....	5
<b>Dédicace</b> .....	3
<b>Remerciements</b> .....	9
<b>Résumé</b> .....	11
<b>Summary</b> .....	13
<b>Chapter 1. General introduction to the topic</b> .....	15
1.1. Human African Trypanosomiasis.....	16
1.2. The tsetse fly vector.....	16
1.3. Tsetse fly visual system.....	19
1.4. Spectral sensitivity of tsetse visual system.....	20
1.5. Resting site preferences of tsetse.....	21
1.6. Visual baits for sampling and controlling tsetse populations.....	22
1.6.1. <i>Traps for riverine group tsetse</i> .....	23
1.6.2. <i>Traps for savannah group tsetse</i> .....	26
1.6.3. <i>Traps for forest group tsetse</i> .....	31
1.6.4. <i>Efficiency of tsetse trap for other flies</i> .....	32
1.7. The use of targets (two-dimensional visual devices) impregnated with insecticides for tsetse control.....	32
1.8. Perspective for improvement of visual baits for the tsetse population control.....	39
1.9. The situation of sleeping sickness in the Central African Republic.....	40
1.10. Research interests and outline of the thesis.....	42
<b>Chapter 2. The genesis of fundamental survival strategies in tsetse: a laboratory study</b> .....	45
Abstract.....	46
2.1. Introduction.....	47
2.1. Materials and Method.....	49
2.2. Results.....	63
2.4. Discussion and conclusions.....	79
Annex.....	86
<b>Chapter 3. Improvement of landing response of Morsitans tsetse on a small blue target in the wind tunnel</b> .....	89
Abstract.....	90
3.1. Introduction.....	91
3.2. Materials and methods.....	93

3.3. Results .....	105
3.4. Discussion and conclusions .....	123
<b>Chapter 4. The proportion of polyester in deltamethrin-impregnated visual targets affects their efficacy for controlling tsetse .....</b>	<b>129</b>
Abstract .....	130
4.1. Introduction.....	131
4.2. Materials and methods .....	133
4.3. Results .....	137
4.4. Discussion and conclusions .....	143
<b>Chapter 5. General discussion and research perspectives .....</b>	<b>147</b>
<b>References .....</b>	<b>154</b>

## Dédicace

*A tous ceux qui souffrent de la maladie du sommeil  
dans des endroits inaccessibles à notre aide*



## Remerciements

Mes sincères remerciements vont à l'endroit de tous ceux qui ont contribué à promouvoir cette thèse, en particulier :

Dr Patrick Guerin qui m'a accepté dans son laboratoire pour la réalisation de cette thèse, qui a toujours été disponible pour des discussions très constructives, qui m'a toujours encouragé tout en procurant des conseils très précieux, qui a toujours accepté de corriger mes manuscrits avec plaisir et qui, enfin, manifeste un intérêt très touchant à l'intégration de ce travail dans la stratégie de lutte contre la maladie du sommeil dans mon pays;

Dr Silla Semballa qui nous a procuré une formation de haut niveau en master de biochimie de l'Université de Bangui (République centrafricaine);

Feu Dr Auguste Nangouma qui a appuyé mon dossier auprès de la Commission Fédérale Suisse des Bourses pour Etudiants Etrangers (CFBE);

Dr Balázs Bernáth qui a construit certains matériels utilisés dans ce travail comme l'arène de vol libre des insectes et a mis en place la station électrophysiologique permettant l'enregistrement des électrorétinogrammes dans ce travail, qui a aussi inlassablement apporté son expertise dans le domaine de la vision des insectes;

Dr Adam Egri qui a automatisé la station électrophysiologique en construisant un stroboscope adapté;

Dr Armelle Jeanine Vallat qui a fait les analyses chimiques pour la détermination des quantités de deltaméthrine des tissus imprégnés et exposés aux intempéries;

Dominique Schenker qui a apporté son aide précieuse pour la mesure de la lumière résiduelle dans la chambre environnementale utilisée pour les expériences dans ce travail;

Francis Oloo pour sa collaboration précieuse depuis le Kenya à la réussite de ce travail;

Daniel Varidel et Christian Hêche du Service Technique de la Faculté des Sciences de l'Université de Neuchâtel pour leurs précieux appuis techniques;

Dr Radu Slobodeanu pour son aide et conseil en statistique;

Laboratoires Siebeersdorf de l'Agence International de l'Energie Atomique (Vienne, Autriche) pour la fourniture régulière des pupes des mouches tsétsés;

Mónica Guadalupe Hernández Estrada, Alexandre Vernudachi, Dr Thomas Kröber, Andrew Stewart McMullen, Martine Bourquin, Cécile Villiger, Andrea Gomez Chamorro, Dr Alexandre Gurba, Victor Anstett, Aurore Jordan, Daniel Stone, Dr Charles Chappuis, Dr Sébastien Kessler et Dr Jonas Durand;

Mes parents qui m'ont montré le chemin de la réussite avec amour, vous êtes les meilleurs parents au monde;

Mes frères et sœurs qui partagent mes joies et mes moments difficiles;

Ma fille Adeline Clarenca Kamba Yambomba et tous mes neveux et nièces qui m'apportent beaucoup de joie;

La famille Monod que j'ai rencontrés à Neuchâtel alors qu'ils avaient vécu trente (30) ans en République centrafricaine, leur amitié chaleureuse m'a été d'un très grand soutien;

Les familles Horner, Rey et Bouvier pour leurs encouragements et conseils;

Mes collègues boursiers de la Confédération suisse : Xavier Chiriboga, Simplicie Ayangma, Fernanda Celis Gonzales, Choudhury Rimjhim Roy, Jamil Isha, Fares Bellameche, Désiré Manirakiza, etc.

Mes amis de la cité universitaire de Neuchâtel : Shaban Xhafer, Asma Zouari, Gary Mollard, Amine Garci, Camille Kaufmann, Baptiste Nussbaumer, Jihane Haoues;

L'Université de Neuchâtel et plus particulièrement Romain Bessire de la maintenance informatique, Delphine Lab et Pascale Prêtre de la bibliothèque avec leur soutien inconditionnel dans la recherche bibliographique;

À la Confédération suisse pour l'opportunité qui m'a été offerte, je souhaite que la collaboration entre la Suisse et la République centrafricaine se renforce durablement.

## Résumé

Les mouches tsétsés sont des insectes hématophages qu'on trouve en Afrique subsaharienne et dont les espèces sont classifiées en trois principaux groupes écologiques (riverain, savane et forêt). Les mouches tsétsés riveraines et de savane sont les vecteurs potentiels des trypanosomes, parasites qui causent la trypanosomiase (maladie du sommeil), à l'Homme et au bétail à travers leurs piqûres au cours leur repas sanguin. La trypanosomiase est une maladie tropicale négligée qui affecte la santé humaine et cause d'importantes pertes économiques. La réduction de la population des mouches tsétsés par l'utilisation des écrans visuels imprégnés d'insecticide (tissus bleus, noirs ou bleu-noir) reste l'un des moyens efficaces pour lutter contre la maladie. La réduction des écrans visuels standards (1 m x 1 m) aux écrans de petites tailles (25 cm x 25 cm) sont des moyens efficaces et bon marché pour contrôler la population des mouches tsétsés riveraines. Une telle réduction de taille des écrans visuels est inefficace contre les tsétsés de savane. L'objectif principal de cette thèse était de développer des appâts visuels efficaces, bon marché et standardisés qui permettent de contrôler les populations des mouches tsétsés.

Le control et l'éradication des mouches tsétsés requièrent une solide connaissance de leur comportement et de leur écologie. J'ai d'abord exploré au laboratoire le comportement au repos de *Glossina pallidipes* qui est une mouche tsétsé de savane (groupe Morsitans). J'ai montré que (1) le fait de trouver une perche au-dessus du sol est un comportement fondamental de survie chez *G. pallidipes* qui est capable de voler vers des sites de repos dans l'obscurité estimée à 10 fois plus bas que l'illumination pendant une nuit à ciel couvert et (2) le choix des sites de repos diurnes par les mouches est lié à leur résolution visuelle déterminée par leurs réponses optomotrices et par électrorétinographie. Ensuite, j'ai travaillé suivant l'hypothèse que les sites de repos horizontaux des mouches tsétsés (branches horizontales dans la nature) pourraient être des substrats d'atterrissage efficaces de ces mouches lorsqu'ils sont associés à des écrans visuels. Le comportement en vol et l'atterrissage de *G. pallidipes* sur des écrans visuels bidimensionnels et tridimensionnels dans une arène circulaire de vol libre et dans une chambre de vol confirment que *G. pallidipes* s'approche d'un objet visuel par le dessous et explore l'objet en volant autour de la partie inférieure de celui-ci. Une barre en bois de 1.5 cm de diamètre recouverte d'un tissu mat noir et placé horizontalement à la base d'un écran carré bleu (25 cm x 25 cm) augmente les atterrissages de *G. pallidipes* de facteur 2

sur l'écran comparé à l'écran tout bleu dans la chambre de vol. L'écran bleu incorporant une barre noire à la base est prometteur d'un dispositif rentable à utiliser comme appâts visuels imprégnés d'insecticide pour contrôler la population des mouches tsétsés. Enfin, la question de la persistance de deltaméthrine, un insecticide de la classe des pyréthroïdes actuellement utilisé pour le contrôle des tsétsés, a été traitée. L'effet de l'exposition dans les conditions naturelles (Lambwe Valley, Kenya) sur la capacité de quatre différents textiles contenant des proportions croissantes (0, 35, 65 et 100%) de polyester et imprégnés de deltaméthrine a été évalué. Ces textiles ont été saturés d'une solution aqueuse de deltaméthrine à 1000 mg/m<sup>2</sup> et ont été exposés au champ durant 18 mois. La toxicité sur *G. pallidipes* de ces textiles imprégnés de deltaméthrine et exposés au champ a été évaluée sur 24 heures après 45 secondes de contact de ces textiles avec les mouches. Seuls les textiles constitués de polyester à 65% et 100% étaient capables de tuer respectivement 47 et 67% de *G. pallidipes* après 9 mois d'exposition dans les conditions naturelles. Le textile à 100% polyester était encore capable de paralyser toutes les mouches après 18 mois d'exposition au champ. La dose létale de deltaméthrine pour tuer 50% (DL<sub>50</sub>) de *G. pallidipes* était estimée à 30 mg/m<sup>2</sup> sur du papier buvard tandis que le textile à 100% polyester conservait 17 mg/m<sup>2</sup> après 9 mois d'exposition au champ et causait une mortalité de 67% chez les mouches soulignant l'influence du type de matériel sur la disponibilité de l'insecticide aux mouches tsétsés. Sur la base de l'ensemble des résultats de cette thèse, une perspective de recherche a été proposée pour la République centrafricaine qui abrite quatre foyers de trypanosomiase où la lutte contre les mouches tsétsés a longtemps été négligée.

**Mots clés:** la mouche tsétsé, *Glossina Pallidipes*, comportement chez les insectes, géotaxie négative, site de repos, résolution visuelle, réponse optomotrice, électrorétinographie, chambre de vol, appâts visuels, atterrissages des mouches, deltaméthrine, control des populations des tsétsés.

## Summary

Tsetse flies are bloodsucking insects found in Sub Saharan Africa and can be classified in three main ecological groups (riverine, savannah, forest). Riverine and savannah tsetse are major vectors of trypanosomes, parasites that cause trypanosomiasis (sleeping sickness) to humans and animals through biting while taking a blood meal. Sleeping sickness is a neglected tropical disease that affects human health and causes substantial economic losses. Reducing tsetse population density using insecticide-impregnated visual targets (blue, black or blue-black textiles) remains one of the most efficient methods to achieve disease control. Reducing the size of visual targets from the standard size (1 m x m) to 25 cm x 25 cm smaller targets has been found as a cost-efficient tool to control *Palpalis* (riverine) tsetse. Such a reduction in size in visual targets does not work for *Morsitans* (savannah) tsetse. The main goal of this thesis was to develop cost-efficient and standardized visual baits permitting to control populations of tsetse.

The control and eradication of tsetse requires a solid knowledge of their behaviour and ecology. Firstly, I investigated the resting behaviour of *Glossina pallidipes*, a *Morsitans* tsetse species, through laboratory studies. I show that (1) finding perches off the ground, namely negative geotaxis, is a fundamental survival behaviour in *G. pallidipes* that is able to fly to resting sites in near darkness estimated at 10 times lower than the illumination during an overcast night, and (2) the choice of diurnal resting sites by the flies is related to their visual resolution as assessed by optomotor reactions and by electroretinography. Secondly, I worked under the hypothesis that horizontal resting sites for tsetse (horizontal branches in the field) could provide efficient landing substrates for the flies when associated to visual targets. Assessing behaviours in flight and landing responses by *G. pallidipes* on two- and three-dimensional visual targets in a circular free-flight arena and in a wind tunnel confirmed that *G. pallidipes* approaches a visual object from the below and investigates the object by flying around the bottom part of it. A 1.5 cm diameter wooden bar covered by black matt textile and placed horizontally at the base of a 25 cm x 25 cm blue square target increased landings by *G. pallidipes* on the target by a factor 2 compared to the all blue target in the wind tunnel. A blue target incorporating a black bar at the base shows promise as a cost-effective device to use as visual bait impregnated with insecticide for controlling tsetse. Finally, the question of the persistence of deltamethrin, a pyrethroid insecticide, currently used on targets for tsetse

control was treated. The effect of weathering (in the Lambwe Valley, Kenya) on the capacity of four different deltamethrin-impregnated textiles, with increasing proportions (0, 35, 65 and 100%) of polyester was assessed. Such textiles, saturated with an aqueous solution of deltamethrin at 1000 mg/m<sup>2</sup>, were weathered for 18 months. The toxicity to *G. pallidipes* of deltamethrin-impregnated and weathered textiles was evaluated over 24 h after 45 seconds of contact with the flies. Only textiles made of 65 and 100% polyester were able to kill 47 and 67% of *G. pallidipes*, respectively, after 9 months of weathering. The 100% polyester textile was still able to knock down all flies exposed to it after 18 months of weathering. The estimated lethal dose of deltamethrin for killing 50% (LD<sub>50</sub>) *G. pallidipes* was 30 mg/m<sup>2</sup> on blotting paper whereas the 100% polyester textile retained 17 mg/m<sup>2</sup> after 9 months of weathering and caused 67% mortality in flies, underlining the influence of the type of material on the availability of the insecticide to tsetse. On the basis of results presented in this thesis, a research perspective is proposed for the Central African Republic that harbours four foci of Human African Trypanosomiasis and where tsetse control has long been neglected.

**Keywords:** tsetse, *Glossina Pallidipes*, insect behaviour, negative geotaxis, tsetse visual resolution, optomotor response, electroretinography, wind tunnel, visual baits, fly landing responses, deltamethrin, tsetse control.

## **1. General introduction to the topic**

### 1.1. Human African Trypanosomiasis

Human African Trypanosomiasis (HAT), also known as sleeping sickness, is a neglected tropical disease that impacts 70 million people distributed over 1.55 million km<sup>2</sup> in Sub Saharan Africa (Simarro et al., 2012). Current new cases are estimated at about 30,000 per year (7,197 reported new cases in 2012 (WHO, 2014)). Livestock is also affected by Animal African Trypanosomiasis (AAT) known as “nagana”: about 50 000 cattle in 37 countries, with consequences for agriculture (FAO, 1998) and causes major economic losses to countries already strained for resources (Shaw, 2004). The parasites are trypanosomes, transmitted to the mammalian hosts through the bite of an infected tsetse fly.

Achieving disease control in mammalian hosts is demanding given the lack of effective mammalian vaccines. The challenge is to identify control methods to ensure that the endemic areas remain free of sleeping sickness. Several methods are used against the disease and its vectors: the use of medical treatment based on Niflurtimox and Eflornithine (Priotto et al., 2009) against *Trypanosoma brucei gambiense*, the major parasite responsible for more than 80% of the total number of reported human cases of HAT (Simarro et al., 2008, Simarro et al., 2012); the use of the sterile male technique (Vreysen, 2001), insecticide-treated cattle (Hargrove et al., 2003) and the use of insecticide-impregnated traps and targets for tsetse fly population control (Mangwiro et al., 1999). The latter is certainly one of the most efficient methods due to the low reproduction rate of tsetse (Hargrove, 2004) and the relatively low infection rates (<0.1%) by parasites in tsetse (Koffi et al., 2009). Thus, reducing tsetse population density reduces infection rates in humans and animals.

### 1.2. The tsetse fly vector

Tsetse flies are bloodsucking insects found in Sub Saharan Africa. Tsetse transmit trypanosome parasites through biting while taking a blood meal on a human or an animal (Figure 1). Tsetse are commonly divided into three ecologically distinct groups: savannah tsetse (= *Morsitans* group) which are largely responsible for transmitting the trypanosomes that cause nagana; riverine tsetse (= *Palpalis* group) which play a major role in the transmission of *Trypanosoma brucei spp.*, the causative agents of sleeping sickness; and forest tsetse (= *Fusca* group) which, generally speaking, do not play an important epidemiological role. Tsetse are believed to be extremely old insects since fossil tsetse have been identified from the Florissant Fossil Beds in Colorado (Cockerell, 1917). Today living tsetse are almost

exclusively found on the African continent south of the Sahara (Rogers and Robinson, 2004). Some 29 to 31 species and sub-species (depending on the classification) have been identified. However, only few of them are recognized as vectors of sleeping sickness (Table 1.1), incriminated in the transmission of pathogenic parasites (WHO, 2014). Mechanical vectors of trypanosomes like Tabanidae, Stomoxidae and Hippoboscidae can also transmit some parasites. *Trypanosoma congolense* was identified in Tabanidae in Burkina Faso (Solano and Amsler Delafosse, 1995) and *Atylotus agrestis* (Diptera: Tabanidae) can transmit *Trypanosoma vivax* and *Trypanosoma congolense* to cattle (Desquesnes and Dia, 2003a, Desquesnes and Dia, 2003b).

Tsetse breed by the adenotrophic viviparity mode of reproduction. After copulation, only one egg is fertilized at the time, and the development of three larval stages occurs in the uterus (Fig. 1.2). The larva is fed with a form of milk produced by specialized glands in the uterus. The third instar is deposited on the ground and the larva burrows into the soil to pupate. Pupal duration varies with temperature and lasts about 30 days at 25°C. A female can produce a larva every 8-10 days (Hargrove, 2004), or 6 offspring within a mean lifespan of 2 months. This low reproductive rate classifies tsetse as k-strategists (Carey, 2001) facilitates the control of tsetse populations with visual traps and targets.



**Fig. 1.1.** The tsetse fly *Glossina bevipalpis* feeding on a human arm (Chappuis, 2013)

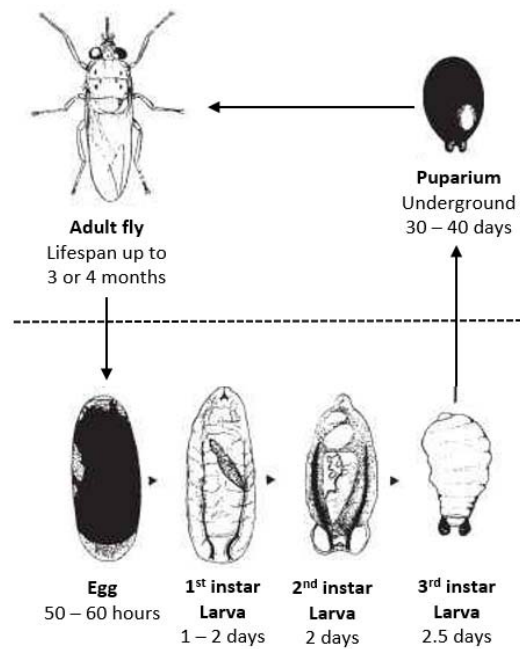

Fig. 1.2. Life cycle of the tsetse fly

**Table 1.1. Tsetse incriminated in the transmission of sleeping sickness (Brunhes et al., 1998)**

Group	species	host	zones
<b>palpalis</b>	<i>G. tachinoides</i>	human-animal	central and west Africa
	<i>G. p. palpalis</i>	human-animal	central and west Africa
	<i>G. p. gambiensis</i>	human-animal	central and west Africa
	<i>G. f. fuscipes</i>	human-animal	central and east Africa
	<i>G. f. martinii</i>	human-animal	central and east Africa
	<i>G. f. quanzensis</i>	human-animal	central and east Africa
<b>morsitans</b>	<i>G. pallidipes</i>	human-animal	east Africa
	<i>G. swinnetorni</i>	human-animal	east Africa
	<i>G. austeni</i>	animal	east Africa
	<i>G. m. morsitans</i>	human-animal	east Africa
	<i>G. m. centralis</i>	human-animal	central and east Africa
	<i>G. m. submorsitans</i>	animal	central and west Africa
	<i>G. longipalpis</i>	animal	central and west Africa

### 1.3. Tsetse fly visual system

Tsetse are diurnal and visual stimuli are one of the most important determinants in fly behaviour. These insects have over half the head comprised of two large compound eyes accompanied by a cluster of simple eyes (ocelli). The term "ocellus" (plural ocelli) is derived from the Latin *oculus* (eye), and literally means "little eye". Two distinct ocellus types exist: dorsal ocelli (or simply "ocelli"), found in most insects, and lateral ocelli (or stemmata), which are found in myriapods and in some insect larvae. Compound eyes are composed of multiple functional units called ommatidia. Each ommatidium is composed of the dioptric structures (cornea and cone), photosensitive cells (retinula cells with rhabdoms) and shielding cells (pigment cells surrounding retinula cells and the cone; Fig. 1.3). In the apposition eyes of diurnal insects like tsetse, rhabdoms extend from the cone to the basement membrane and there is little to no movement of the pigment in the shielding cells so that light strikes the photosensitive pigment only when entering axially, shielded from light straying from adjacent ommatidia. The eyes of tsetse are very similar to other higher dipterans with the exception that the number of the surrounding secondary pigment cells is unusually high at 16-18 (Hardie et al., 1989). Reflected light enters the compound eyes or ocelli and stimulates photosensitive cells that trigger phototransduction, which converts photons into electrical signals which are transmitted to the insects optic lobes (Zuker, 1996).

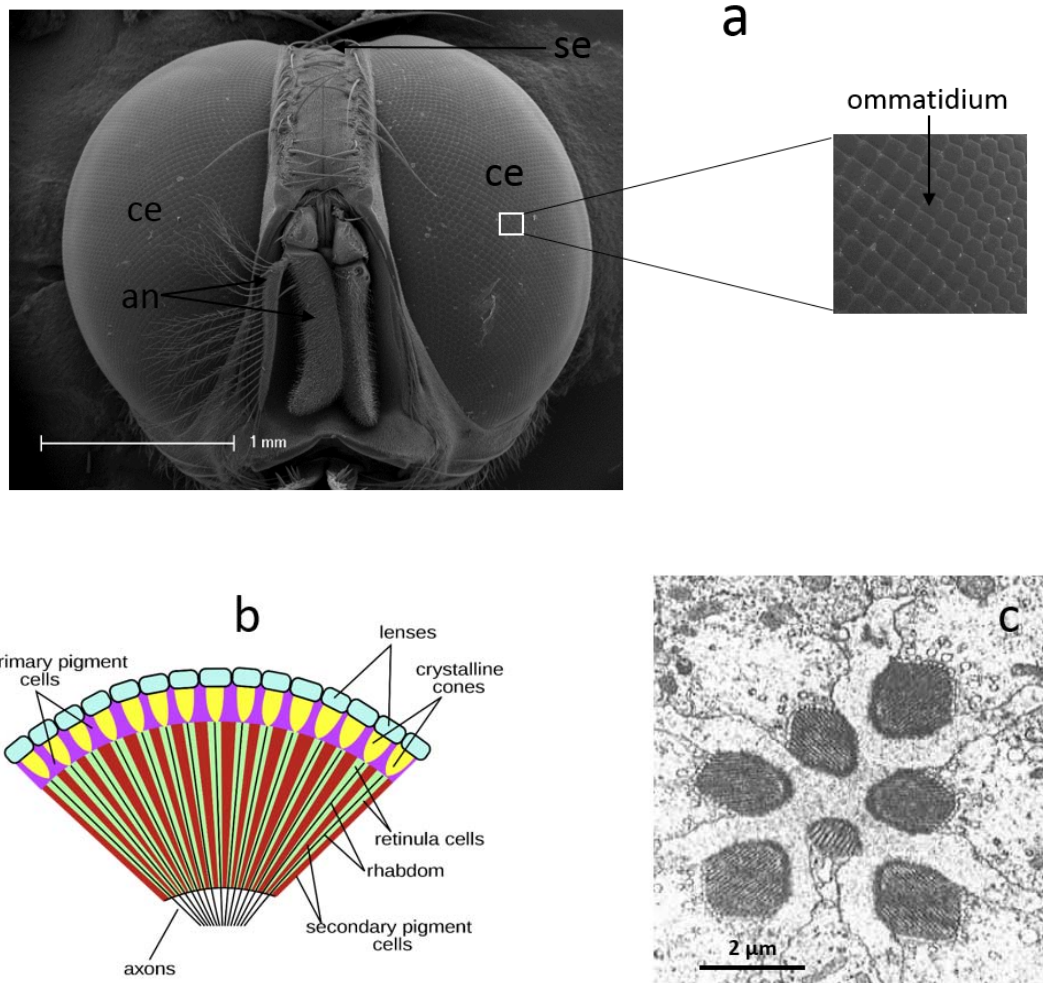
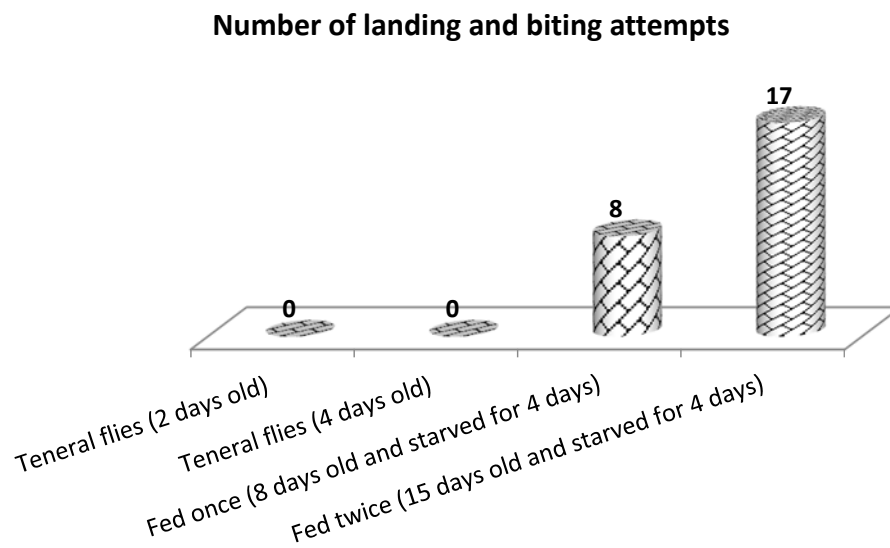

**Fig. 1.3.** (a) Scanning electron micrographs of *G. pallidipes* compound eyes, showing part of the peripheral ommatidia openings; **an** = antenna; **ce** = compound eye; **se** = simple eye. (b) Transverse section through an insect compound eye (<http://www.earthlife.net/insects/anat-head.html>) and (c) transmission electron micrograph of a tangential section through the eye of *G. morsitans morsitans* showing the typical dipteran open rhabdom, with the central rhabdomere (R7) significantly smaller than the peripheral rhabdomeres (R1-6) (Hardie et al., 1989).

#### 1.4. Spectral sensitivity of tsetse visual system

The spectral sensitivity, i.e. perception of different parts of the light spectrum of the savannah species *G. morsitans morsitans* has been established by electroretinography. Findings show that wavelengths in the blue part of the spectrum (450-520 nm) are most stimulating followed by wavelengths around 625 nm in the visible part of the light spectrum, with a strong peak in the ultraviolet part of the spectrum at 350 nm (Green and Cosens, 1983). This sensitivity explains the use of blue colour in control devices (Challier and Laveissière, 1973, Gouteux and Lancien, 1986). Sensitivity to the other parts of the light spectrum (infrared) and the spectral sensitivity of tsetse species from other groups (riverine and forest)

have not been documented. We have observed, however, that laboratory reared *G. pallidipes* was able to fly in a 35 x 35 x 55 cm Plexiglas® under an infrared source emitting light at 950 nm beyond of tsetse spectral sensitivity. More intriguing, starved flies (fed at least once) were more active and they even landed and attempted to bite on the floor of the cage (Fig. 1.4). This aroused our curiosity to investigate night vision in such flies. Vanderplank (1941) found that *G. pallidipes* seemed to be more active on days following moonless nights than on days following moonlit nights. This suggested that flies were more active on moonlit nights than on dark nights and were therefore less active the following day. Both sexes of *G. pallidipes* may be active throughout the night on moonlit nights (Chorley and Hopkins, 1942).



**Fig. 1.4.** Activity of *G. pallidipes* (n =15) in a Plexiglas® cage (35cm x 35cm x 45cm) in presence of infrared light. Numbers accounted for over 15 min are flies landing and biting on the floor (black cardboard) of the cage.

### 1.5. Resting site preferences of tsetse

Tsetse rest for most of the day, making use of sites that provide protection from extreme temperatures and from predators. The sites may also provide vantage points from which to seek hosts, and their location can change according to time of day, season, and hunger stage of the fly. Recently engorged tsetse rest low down on tree trunks; the height above ground level of the resting site increases in relation to the fly's nutritional state: recently engorged flies generally rest on tree trunks while hungry ones prefer higher branches probably to locate hosts for blood meal (Nash, 1952). High temperatures result in tsetse moving to rest in sites such as the boles of large trees, where they squeeze into the fissures of the bark, at

heights generally less than 0.3 m from the ground. Flies can also hide in rot holes, often quite high up, in big tree trunks (Pilson and Leggate, 1962). Horizontal resting sites of tsetse have been documented. For riverine species, Okoth and Kapaata (1987) for example found that *G. f. fuscipes* shows a preference for twigs and the undersides of branches between 0.5-1 cm diameter, while it was observed that *G. p. palpalis* rests mostly on undersides of larger branches of 2.5-5 cm diameter (Abdurrahim, 1971). For savannah species, it was observed that *G. longipalpis* rests most frequently on undersides of stems and horizontal branches with a diameter in a range of 1-6 cm (Omoogun, 1985). This is similar to that noted for *G. pallidipes* that choose branches in the early morning, but flies shift to the rot holes and boles in the middle of the day, followed by a return to branches in the evening (Pilson and Leggate, 1962). The forest specie *G. f. congolensis* rests most frequently on the undersides of horizontal branches with a diameter range of 1-6 cm (Omoogun, 1985), a behaviour that is also reported for the forest species *G. brevipalpis* (Moloo et al., 1980).

### **1.6. Visual baits for sampling and controlling tsetse populations**

The first trapping devices for controlling tsetse were black overalls worn by workers, coated with glue and hung up in the plantations of Sao Tome and Principe in 1910 to trap *G. p. palpalis* (Da Costa et al., 1916). Later, in the 1930s, Harris developed a trap (Fig. 1.5) that was employed with great success in Zululand against *G. pallidipes* (Harris, 1930; Harris 1938). This trap consisted of a wooden frame, a triangular profile on which Hessian or other tissue was stretched. The trap was based on the principle that tsetse are attracted by dark surfaces or shady places and entered into the trap through a slot underneath, moved upwards into the body of the trap and then into a holding cage, a non-return device ensuring the capture of all tsetse entering it. As a further development of the Harris' idea, Morris and Morris (1949) introduced the 'animal' trap whose shape was designed to look like an animal. As described by Muirhead-Thomson (1991), the most important feature of the trap was the cylindrical shape of the body constructed of hessian cloth opened along the ventral surface, producing highlights and shadows from the curved shape. Flies attracted into this dark opening along the under surface were directed from inside through a slit along the upper surface of the trap body, over which a retaining cage was superimposed. These traps were used against *G. palpalis* and *G. tachinoides* in West Africa (Morris and Morris, 1949). A further series of traps followed but were rarely used for controlling tsetse. After the Second World War, trapping

was abandoned as a control method in favour of widespread spraying with DDT (dichlorodiphenyl-trichloroethane), an insecticide discovered by the Swiss chemist Paul Hermann Müller in 1939.

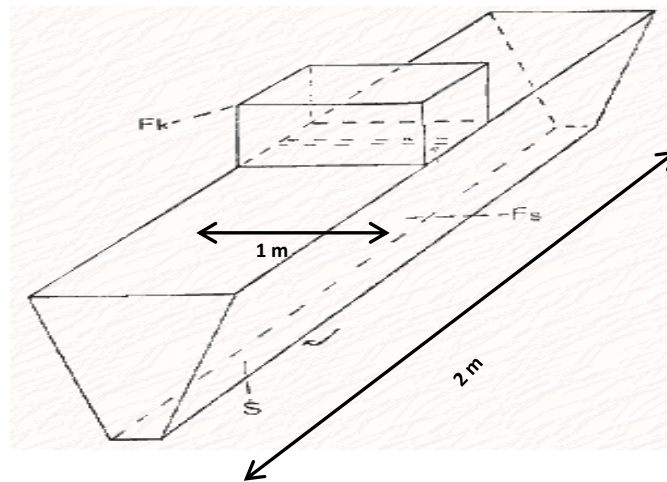

**Fig. 1.5.** Harris trap. **S** bottom slot where flies enter into the trap; **F<sub>s</sub>** body of the trap; **F<sub>k</sub>** cage. (<http://www.sleeping-sickness.ird.fr/zumpt.htm>)

#### **1.6.1. Traps for riverine group tsetse**

It was only in the 1970s that trapping was seriously considered again. The development of the biconical trap (see Table 1.2 for description; Fig. 1.6) by Challier and Laveissière for trapping *palpalis* and *fuscus* group tsetse (Challier and Laveissière, 1973) is based on the principle of Harris trap mentioned above. The original version of this trap was made of two white cones, the upper cone made of white mosquito netting and the lower one made of white cloth. This version was improved by replacing the white cloth of the lower cone by a blue one (Challier et al., 1977). Blue colour was thus introduced into tsetse trapping devices. Flies enter into this trap through 4 holes in the lower cone, which the internal black screen can be seen. As flies are attracted by the daylight coming from the above through the upper netting cone, they move upward and enter into the holding cage placed at the apex of the trap. Based on this original model, simpler traps were developed such as the monoconical trap obtained by replacing the lower cone of the biconical trap by a crossed blue-black screen and by adding blue streamers surrounding the crossed screen (Lancien (1981); Fig. 1.6, Table 1.2). This trap was designed in an effort to make a moving object as the streamers are constantly moved by the wind increasing its attractiveness to tsetse. To protect the device against rain, the upper cone was made of polyvinyl chloride (PVC). Flies land firstly on the blue-black crossed screens before moving upward into the upper cone and then into the holding cage at

the apex. A variant of this trap, the “Vavoua” (Table 1.2 and Fig. 1.6) caught 1.2 times more flies than the biconical trap with a lower blue cone (Laveissière and Grebaut, 1990). The pyramidal trap (Gouteux and Lancien (1986); Fig. 1.6, Table 1.2) was created by replacing the lower cone of the biconical trap by blue-black crossed panels (Table 1.2). According to the authors, the choice of the pyramidal form was due to a desire for simplicity. The metallic ring which supported the cone of previous traps (biconical and monoconical) was replaced by plastic or wooden sticks. The PVC forming the cone was replaced by mosquito netting preventing stronger temperature increase inside the pyramidal trap during hot periods and so increasing tsetse catch. The pyramidal trap worked on the model of the biconical trap but caught 7.5-10 times more flies (Gouteux and Lancien, 1986). All traps currently used have cones made of mosquito netting.



**biconical trap**



**pyramidal trap**



**monoconical “Vavoua” trap**

**Fig. 1.6.** Main traps used for trapping riverine tsetse group flies

**Table 1.2. Main traps developed for *palpalis* (riverine) tsetse group flies**

<b>Tool</b>	<b>Description</b>	<b>Tsetse species concerned</b>	<b>Catch index*</b>	<b>First trials</b>	<b>Reference</b>
Biconical trap 1	Two cones pointing upward and downward, upper cone made of white mosquito netting, lower cone in white cloth pierced by 4 holes; black cross inner screens in the lower cone sewn between holes	Palpalis group	0.4	Ivory cost	Challier and Laveissière (1973)
Biconical trap 2	Two cones pointing upward and downward, upper cone made of white mosquito netting, lower cone in blue cloth pierced by 4 holes; black cross inner screens in the lower cone sewn between holes	Palpalis group	1	Burkina Faso	Challier et al. (1977)
Pyramidal trap	Upper cone made of mosquito netting, lower part in blue and black crossed cloth panels	Palpalis group	7.5-10	Ivory cost	Gouteux and Lancien (1986)
Monoconical "Vavoua"	Upper cone in mosquito netting, lower part in blue-black-blue crossed cloth sewn into the cone	Palpalis and Morsitans group	1.2	Ivory cost	Laveissière and Grebaut, 1990

(\*) catch index was either reported or calculated (by taking biconical trap 2 as reference) from the corresponding reference.

### 1.6.2. Traps for savannah group tsetse

The A7C trap (Table 1.3, Fig. 1.7) was one of the first traps developed for the savannah tsetse species *G. pallidipes* (Vale and Hargrove, 1979). Flies enter into the trap by one of the 4 bottom entrances (0-50 cm above the ground) and arrive into one of the 4 chambers delimited by the crossed black panel inside the body of the trap. Flies are immediately attracted by daylight coming from above through the netting top of the trap. Then the fly moves upwards into the retaining cage. This trap was later replaced by the F3 trap (Table 1.3, Fig. 7.1), a blue version of the F2 trap (Flint, 1985). Here, flies were attracted by the shadow zone at the body of the trap and seen through the large bottom entrance (0-45 cm above the ground). Once in the trap, flies moved upwards into the netting cone and then into the retaining cage. The Epsilon trap which was conceived on the same principle as the F3 trap but set up on a triangular base, was found to be very efficient for *G. m. morsitans* (Flint, 1985). The Ngu trap (Brightwell et al. (1987); Table 1.3, Fig. 1.7) was created and required less materials to build. The overall design was a blue-black-blue device topped by a cone made of white mosquito netting. The black front shelf inclined towards the inside of the trap created in addition a shadow in the body of the trap. Flies entered into the shady place and moved up into the cone, then into the holding cage at the top of the cone. Researches also focussed on other less studied savannah species *G. swynnetorni* for which the S3 trap was developed (Ndegwa and Mihok (1999); Table 3.1, Fig. 7.1) and operated on the same general principle of black surfaces and upwards flight responses inside the trap. This trap is a particularity because of the white panels joining the lower edges of the black internal screens and the bottom white mosquito netting of the trap (Fig. 1.7). The efficiency of the trap was due to the black and white contrast sewn between entrances to the trap. The most recent trap developed for savannah tsetse is the Nzi trap for *G. pallidipes* (Mihok (2002); Table 1.3, Fig. 1.7). A white vertical band made of mosquito netting divides the black inner portion into a black-white-black screen sewn through the large entrance of the trap. Tsetse are attracted into the trap by the black inner panels, they pass below the horizontal blue front shelf and then move upwards into the cone and the holding cage. The Tetra trap is efficient against both savannah and riverine species (Dia et al. (2008 ), Table 1.13 Fig. 1.7), with tsetse enter into the trap between upper edges of panels and the cone, or between lower edges of panels and the ground. The Mbangala Trap was recently developed in Ghana for *G. m. morsitans* (Esen, 2013). As in the case of the Ngu and the Nzi traps tsetse enter into the Mbalanga trap by

passing under the blue horizontal shelf before moving up into the cone and into the holding cage at the top.

**Table 1.3. Main traps developed for *Morsitans* (savannah) tsetse group flies**

<b>Tool</b>	<b>Description</b>	<b>tsetse species concerned</b>	<b>Catch index*</b>	<b>First trials</b>	<b>Reference</b>
A7C trap	A truncated cone with the base facing up, outside white. The target was a crossed black cloth set inside the cone and sewn between 4 triangular entrances at the bottom sides of the trap. It had 4 retaining cages at top.	<i>Morsitans</i> group	No comparative studies with other traps	Zimbabwe	Vale and Hargrove (1979)
F3 trap (blue version of F2 trap)	White cone in mosquito netting set in a square base made of black and white cotton cloth stretched over a cube metal frame (90cm x 90cm x 90cm), The body was covered by a blue cloth, providing a 90 x 45 cm bottom front entrance.	<i>Morsitans</i> group	1	Zimbabwe	Flint (1985)
Epsilon trap	White cone in mosquitoes netting set in a triangular base made of blue cotton cloth stretched over three metal poles (90cm high), the body was closed by a blue top front shelf providing a 90 x 45 cm bottom front entrance. The inside corner opposite the entrance is lined with a black band as an internal baffle.	<i>Morsitans</i> group	2	Zimbabwe	Flint (1985)
Ngu trap	Upper white netting cone, lower part in blue cloth opens in a half circle; the opened face just under the netting was closed by a black top front shelf inclined towards the inside of the trap, leaving a bottom front entrance.	<i>G. pallidipes</i>	2.8	Kenya	Brightwell et al. (1987)
S3 trap	The royal blue triangular sides are 90 x 90 cm, "wings" (90 x 30 cm) added, with three central entrances (40 x 40 cm), one on each side, and 8 cm above the bottom. A white netting bottom is also added to the trap. The interior consists of a target made of three black panels (58 x 25 cm) joined together on the longer axis into a three vanned design visible from the outside through each of the entrances. White panels are similarly designed and join the lower edges of the target, touching the bottom white netting.	<i>G. swynnertoni</i>	2.8	Kenya	(Ndegwa and Mihok, 1999)
Nzi trap	The body is in the shape of an equilateral triangle flanked by two blue wings at the front. The sides are half black towards the front and half netting towards the back. A trapezoidal netting shelf extends horizontally from the bottom of the front shelf to the midpoint of the sides, leaving a gap at the back through which insects fly up into the cone. The cone is a netting tetrahedron.	<i>G. pallidipes</i>	2.8	Kenya	Mihok (2002)

Tetra trap	Horizontal upper blue panel tilted inwardly to form additional entrances. Furthermore this façade reproduced four times in radial symmetry. In addition, bands made of black cloth join the upper and lower edges of each blue panel.	<i>Palpalis and Morsitans</i> group	No comparative studies with other traps	Burkina Faso	Dia et al. (2008 )
Mbangala Trap	Blue outside, with the upper half of the front (120 x 22 cm) sewn separately to the 3 edges of the main cloth and then stitched to the white netting. The target has a crossed black piece of cloth 22 cm x 26 cm sewn onto each of the 3 blue cloth panels (90 cm x 52 cm). The cone is recessed half way into the trap as an asymmetric pyramid with its apex to the fore of centre and level with the trap top a collecting bag.	<i>G. m. morsitans</i>	3	Tanzania	Eseno (2013)

(\* ) catch index was either reported or calculated (by taking F3 trap as reference) in the corresponding reference.

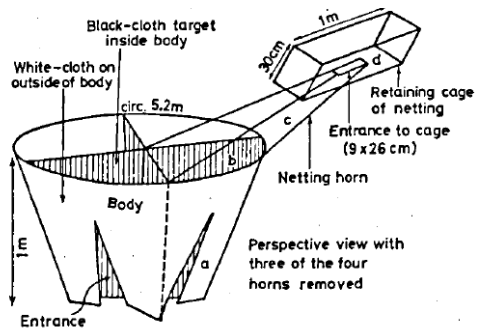

A7C trap



F3 trap



Epsilon trap



Ngu trap

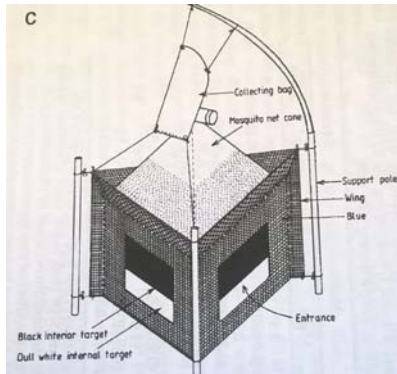

S3 trap



Nzi trap



Tetra trap (Big and small)

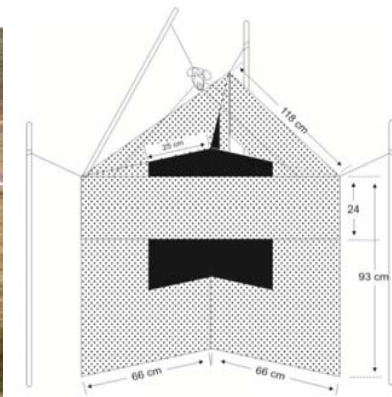

Mbangala trap

Fig. 1.7. Main traps used for trapping savannah tsetse group flies

### 1.6.3. Traps for forest group tsetse

The biconical and the Ngu traps have also been used for forest group tsetse. The best trap used to date is the H-trap (Kappmeier (2000b); Table 1.4, Fig. 8.1) for trapping *G. brevipalpis*. Unlike other tsetse species, the upward flight responses of *G. brevipalpis* is very low. The principle of trapping is based on the horizontal flight of *G. brevipalpis* and *G. austeni* (two cones of white mosquito netting extending from the lateral ends in opposite directions) and also most probably based on the large zigzags of about 1 m in flight as shown in the laboratory for *G. brevipalpis* (Gurba et al., 2012) hence the large entrance of the trap. *G. brevipalpis* is lured to enter into the trap by an internal black crossed panel which enhances shadow in the body of the trap. Once inside, *G. brevipalpis* is attracted by the daylight through lateral netting cones. They fly horizontally towards them and enter into the holding cages set up at the apex of the cones.

**Table 1.4. Main trap developed for *fusca* (forest) tsetse group**

Tool	Description	Concerned tsetse species	First trials	Reference
H-trap	Consisting of phthalogen blue cloth box (100 x 65 x 65 cm), an inner black cloth X-target acting as a baffle attached to the centre of the roof, and two horizontal cones of white mosquito netting extending laterally from the ends of the trap in opposite directions.	<i>G. brevipalpis</i>	South Africa	Kappmeier (2000b)



**H trap**

**Fig. 1.8. Main trap used for trapping *G. brevipalpis* (forest group species)**

#### 1.6.4. Efficiency of tsetse trap for other flies

Table 1.5 modified from Bouyer et al. (2005) shows the efficiency of tsetse traps for other biting flies such as tabanids (Diptera, Tabanidae) whose females feed on the blood of vertebrates, and *Stomoxys* (Diptera, Muscidae) where both sexes suck blood. All traps designed for tsetse are more or less efficient for tabanids and stomoxys. This observation underlines the propensity of bloodsucking insects to attack visual objects from below. Trap function is strongly based on the flight behaviour of these insects. It has been reported that the Morris trap (animal-model) conceived for tsetse were used successfully to trap African tabanids (Morris, 1963).

**Table 1.5. Tsetse trap efficiency for other biting flies (Table modified from Bouyer et al. (2005))**

Tools	Riverine tsetse		Savannah tsetse		Others biting flies	
	<i>G. palpalis</i>	<i>G. tachinoides</i>	<i>G. longipalpis</i>	<i>G. morsitans</i>	Tabanids	<i>Stomoxys</i>
<b>Biconocal trap</b>	++++	+++	++	++	+	++
<b>A7C trap</b>	No data	No data	No data	+++	++	++
<b>Pyramidal trap</b>	++	++	+	+	++	+
<b>Vavoua</b>	+++	++++	+++	++	++	+++
<b>Nzi trap</b>	+++	++	++	+++	+++	++
<b>Big Tetra</b>	+++	++++	++	+++	+++	++
<b>Small Tetra</b>	+++	+++	++	+++	+++	+++

#### 1.7. The use of targets (two-dimensional visual devices) impregnated with insecticides for tsetse control

Control of tsetse has relied increasingly on attracting them to simple insecticide-impregnated 2D targets which require less material to manufacture (Laveissiere et al., 1988). Improvement of 2D targets is focused mainly on three parameters: colour, shape and size. Colour is one of the main factors in attracting tsetse towards targets. Objects made of blue cloth with a reflectance peak at 460 nm (phthalogen blue) have been established as the most attractive (Green and Cosens, 1983; Green, 1988; Lindh et al., 2012), whereas colours such as green, white or black combined with blue significantly improve landing by tsetse on targets

(Green, 1988; Laveissière et al., 1988; Lindh et al., 2009). Black is more suitable for use with blue in the field as dust quickly discolours white fabrics. Recent studies on visual responses of tsetse to different designs of targets have shown that visual targets reduced from the standard size (1m x 1m) to smaller targets catch equivalent or even more flies per unit surface area than the older bigger ones (Tirados et al., 2011; Kaba et al., 2014; Lindh et al., 2009). I have explored the characteristics of the recently developed optimal 2D objects following size reductions, shapes and spatial orientation. To simplify, 2D device efficiencies were compared by taking daily effective landings on each device relative to the unit surface area and the perimeter of the whole device (cloth + flanking nets). For traps which are 3D objects, the area and perimeter perceived by the flies were considered, i.e. for the biconical trap for example, the fly perceives a quadrilateral shape whose perimeter is the sum of the object contours; the surface area is then the sum of two triangular surfaces (two cones perceived as triangular shapes). A quantitative parameter, namely perimeter to surface area ratio (PSR), was defined in order to clarify whether this parameter influences the visual attractiveness of flies to targets as discussed by Oloo et al. (2014). Highest catches were recorded on objects that have a PSR between 6 - 7 for *G. tachinoides* and *G. p. gambiensis* (Table 1.6) whereas for *G. f. fuscipes* and *G. p. palpalis*, the PSR is above 8 as data from smaller targets have been documented for these species (Table 1.7). A PSR of ca. 6 has been found for the better objects to use for *G. pallidipes* and *G. swynnertoni* but a target with a PSR higher than 6 seems inefficient for such tsetse species (Table 1.8). Reducing target size leads to an increase of object perimeter relative to the surface area and this increase plays a role in landing responses of tsetse (Oloo et al., 2014). Moreover, the PSR perceived by flies from 3D objects (3D object simulating a biconical trap) is also ca. 6 and corresponding catches of *G. tachinoides* and *G. p. gambiensis* per unit of surface area are rather good (Table 1.6). These observations are in agreement with the results obtained by Doku and Brady (1989) who investigated the effect of shape on landing responses of *G. m. morsitans* using circular, square and triangular black objects with a fixed surface area (225 cm<sup>2</sup>) in the laboratory. Results showed that a triangular object was the most attractive, followed by the square and circle of same surface area (Doku and Brady, 1989), presumably because the perimeters were 68, 60 and 53 cm, respectively, for the triangle, the square and circle. The contour length of visual devices is an important landing-inducing parameter for tsetse.

Targets (0.5 m<sup>2</sup>, PSR = 6) presented horizontally or vertically induce equivalent or even more landings per unit area by riverine tsetse than those of standard size (Table 1.9). For savannah tsetse, even though comparisons of the efficiency of 0.5 m<sup>2</sup> vertical oblong targets have not been tested, horizontal ones of 0.5 m<sup>2</sup> were as good as targets of standard size to induce landings by savannah tsetse when counted on a fly per unit area basis (Table 1.9). Some studies have already indicated that when a visual object is horizontally extended more savannah tsetse alight on it (Vale, 1993b, Vreysen et al., 1998). To summarize, a horizontally designed blue or blue-black 2D target reduced to an optimal size such that the PSR is around 6 is efficient for controlling almost all tsetse species. Furthermore, the efficiency of black, blue or blue-black 0.25 x 0.25 cm targets for controlling riverine tsetse population has been recently demonstrated (Tirados et al., 2015). Such tiny targets in black alone were found inefficient for savannah tsetse (Table 1.8). To improve and standardize these tiny targets as cost-effective baits against all tsetse groups it is necessary to consider other aspects (3D and blue-black contrast) to combine with the horizontal aspect.

**Table 1.6. Summary of different target sizes tested in the field for *G. tachinoides* and *G. p. gambiensis* (+ E-grids = covered by electric grids)**

Riverine species	Perceived device size (m <sup>2</sup> )	Dimensions (m x m)	Disposition in the field	Perimeter perceived (m)	Daily landing/device	Daily landing/m <sup>2</sup>	Daily landing/unit of perimeter	Perimeter-surface ratio (perceived)	References
<i>G. tachinoides</i>	1	1 x 1 black	square + E-grids	4	22.7	22.7	5.7	4	Esterhuizen et al. (2011b)
	0.0625	0.25 x 0.25 black	square + E-grids	1	2.2	35.2	2.2	16	
	0.5	<b>3 x (1 x 0.5) (blue with little black holes in the cloth centres)</b>	<b>triangular vertical 3D object simulating biconical trap + E-grids</b>	<b>3</b>	<b>47</b>	<b>94</b>	<b>15.66</b>	<b>6</b>	
	1	1 x 1 net-blue-net (1:2:1)	vertical oblong between two nets + E-grids	4	17.9	17.9	4.5	4	Rayaisse et al. (2011)
	0.375	<b>0.75 x 0.5 net-blue-net (1:2:1)</b>	<b>vertical oblong between two nets + E-grids</b>	<b>2.5</b>	<b>20.7</b>	<b>55.9</b>	<b>8.3</b>	<b>6.7</b>	
	0.125	0.5 x 0.25 net-blue-net (1:2:1)	vertical oblong between two nets + E-grids	1.5	5.1	40.8	3.4	12	
	1	1 x 1 blue-black (1:1)	square + adhesive film	4	24	11.9	6	4	Oloo et al. (2014)
	0.375	<b>0.75 x 0.5 blue-black (1:1)</b>	<b>horizontal oblong + adhesive film</b>	<b>2.5</b>	<b>18</b>	<b>24.7</b>	<b>7.2</b>	<b>6.8</b>	
0.25	0.5 x 0.5 blue-black	square + adhesive film	2	13	25.6	6.5	8		
<i>G. p. gambiensis</i>	1	1 x 1 black	square + E-grids	4	11.3	11.3	2.8	4	Esterhuizen et al. (2011b)
	0.0625	0.25 x 0.25 black	Square + E-grids	1	0.17	2.8	0.2	16	
	0.5	<b>3 x 1 x 0.5 blue (with little black holes in the cloth centres)</b>	<b>triangular vertical 3D object simulating biconical trap + E-grids</b>	<b>3</b>	<b>27.5</b>	<b>55</b>	<b>9</b>	<b>6</b>	
	1	1 x 1 blue	vertical oblong between two nets + E-grids	3	7.9	7.9	2.6	4	Rayaisse et al. (2011)
	0.375	<b>0.75 x 0.5 net-blue-net (1:2:1)</b>	<b>vertical oblong between two nets + E-grids</b>	<b>2.5</b>	<b>15</b>	<b>40</b>	<b>6</b>	<b>6.7</b>	
	0.125	0.5 x 0.25 blue net-blue-net (1:2:1)	vertical oblong between two nets + E-grids	1.5	0.4	3.2	0.3	12	

**Table 1.7. Summary of different device sizes tested in the field for *G. f. fuscipes* and *G. p. palpalis* (+ E-grids = covered electric grids)**

Riverine species	Perceived device size (m <sup>2</sup> )	Dimensions (m x m)	Disposition in the Field	Perimeter (m)	Daily landing/device	Daily landing/m <sup>2</sup>	Daily landing/unit of perimeter	Perimeter-surface ratio (perceived)	References
<i>G. f. fuscipes</i>	1	1 x 1 black	square + E-grids	4	10.5	10.5	2.6	4	Lindh et al. (2009)
	0.5	1 x 0.5 black	vertical oblong + E-grids	3	12	24	4	6	
	0.5	1 x 0.5 black	horizontal oblong + E-grids	3	13.3	26.6	4.4	6	
	0.49	0.7 x 0.7 black	square + E-grids	2.8	10.6	21.6	3.8	5.7	
	<b>0.25</b>	<b>0.5 x 0.5 black</b>	<b>square + E-grids</b>	<b>2</b>	<b>13.3</b>	<b>53.2</b>	<b>6.7</b>	<b>8</b>	
	<b>0.0625</b>	<b>0.25 x 0.25 black</b>	<b>square + E-grids</b>	<b>1</b>	<b>6.4</b>	<b>102</b>	<b>6.4</b>	<b>16</b>	
	1	1 x 1 blue-black (1:1)	square + adhesive film	4	5	2.3	1.3	4	Oloo et al. (2014)
	0.25	0.5 x 0.5 blue-black (1:1)	square + adhesive film	2	3	6.4	1.5	8	
	<b>0.0625</b>	<b>0.25 x 0.25 blue-black (1:1)</b>	<b>square + adhesive film</b>	<b>1</b>	<b>2</b>	<b>15.2</b>	<b>2</b>	<b>16</b>	
<i>G. p. palpalis</i>	1	1 x 1 net-blue-net (1:2:1)	square + E-grid	4	77	77	19.25	4	Tirados et al. (2011)
	<b>0.125</b>	<b>0.25 x 0.5 black-blue-black (1:2:1)</b>	<b>vertical + E-grid</b>	<b>1.5</b>	<b>10.5</b>	<b>84</b>	<b>7</b>	<b>12</b>	
	0.125	0.25 x 0.5 net-blue-net (1:2:1)	vertical + E-grid	1.5	7	56	5	12	
	1	1 x 1 blue-black (1:1)	square + adhesive film	4	14	14	3.5	4	Kaba et al. (2014)
	1	1 x 1 blue-black-blue (1:1:1)	square + adhesive film	4	11	11	2.8	4	
	<b>0.25</b>	<b>0.5 x 0.5 blue-black (1:1)</b>	<b>square + adhesive film</b>	<b>2</b>	<b>10</b>	<b>40</b>	<b>5</b>	<b>8</b>	
	1	pyramid (r=0.82; h=0.68) (white) Lower square cloth (1 x 1) (blue-black)	pyramidal trap, white pyramid above, blue-black clothes below	4	13	13	3.25	4	

**Table 1.8. Summary of different targets sizes tested in the field for *G. swynnertoni* and *G. pallidipes***

Savannah species	Perceived device size (m <sup>2</sup> )	Dimensions (m x m)	Disposition in the Field	Perimeter (m)	Daily landing/device	Daily catch/m <sup>2</sup>	Daily landing/perimeter	Perimeter-surface ratio (perceived)	References
<i>G. swynnertoni</i>	1	1 x 1 (blue-black)	square + adhesive film	4.0	99.2	99.2	24.8	4.0	Mramba et al. (2013)
	1	1 x 1 (blue-black-blue)	square + adhesive film	4.0	84.8	84.8	21.2	4.0	
	<b>0.49</b>	<b>0.55 x 0.9 (blue-black-blue)</b>	<b>horizontal + adhesive film</b>	<b>3.0</b>	<b>48.1</b>	<b>96.4</b>	<b>16.0</b>	<b>6.1</b>	
	<b>0.49</b>	<b>0.55 x 0.9 (blue)</b>	<b>horizontal + adhesive film</b>	<b>3.0</b>	<b>34.22</b>	<b>68.44</b>	<b>11.4</b>	<b>6.1</b>	
	0.47	(0.7 x 0.64) leg panel	horizontal + adhesive film	3.4	31.0	66.0	9.1	7.3	
	0.32	(0.65 x 0.46) leg panel	horizontal + adhesive film	2.7	22.0	68.8	8.2	8.4	
	0.25	0.5 x 0.5 (blue)	square + adhesive film	2.0	17.1	68.5	8.6	8.4	
	0.25	0.5 x 0.5 (blue-black-blue)	square + adhesive film	2.0	18.4	73.6	9.2	8.0	
	1	pyramid (r=0.82; h=0.68) (white) Lower square cloth (1 x 1) (blue-black)	pyramidal trap, white pyramid above, blue-black clothes below	4	59.1	59.1	14.77	4.0	
<i>G. pallidipes</i>	1	1 x 1 (blue-black)	square + adhesive film	4.0	64.5	64.5	16.1	4.0	Mramba et al. (2013)
	1	1 x 1 (blue-black-blue)	square + adhesive film	4.0	69.6	69.6	17.4	4.0	
	<b>0.49</b>	<b>0.55 x 0.9 (blue-black-blue)</b>	<b>square + adhesive film</b>	<b>3.0</b>	<b>39.54</b>	<b>79.08</b>	<b>13.18</b>	<b>6.1</b>	
	<b>0.49</b>	<b>0.55 x 0.9 (Blue)</b>	<b>square + adhesive film</b>	<b>3.0</b>	<b>41.6</b>	<b>84.9</b>	<b>13.9</b>	<b>6.1</b>	
	0.25	0.5 x 0.5 (blue)	square + adhesive film	2.0	10.6	42.4	3.5	8.0	
	0.25	0.5 x 0.5 (blue-black-blue)	square + adhesive film	2.0	8.1	32.2	2.7	8.0	
	1	pyramid (r=0.82; h=0.68) (white) Lower square cloth (1 x 1) (blue-black)	pyramidal trap, white pyramid above, blue-black clothes below	4	8.8	8.8	2.2	4.0	
<i>G. pallidipes</i>	1	1 x 1 (black)	square + E-grid	4	21.7	21.7	5.4	4.0	Torr et al. (2011)
	0.0625	0.25 x 0.25 (black)	square + E-grid	1	0.9	14.4	0.9	16.0	
<i>G. m. morsitans</i>	1	1 x 1 (black)	square + E-grid	4	14	14	3.5	4.0	
	0.0625	0.25 x 0.25 (black)	square + E-grid	1	0.4	6.4	0.4	16.0	

**Table 1.9. Efficiency of small (0.5 m<sup>2</sup>) visual targets at inducing landing by tsetse (horizontal = 1 m x 0.5 m; vertical = 0.5 m x 1 m; standard = 1 m x 1 m)**

Species	Group	Target 0.5 m <sup>2</sup>	Catch/m <sup>2</sup>	Catch/m <sup>2</sup> on the standard	references
<i>G. f. fuscipes</i>	Riverine	black horizontal	26.6	10.5	Lindh et al. (2009)
<i>G. f. fuscipes</i>	Riverine	black vertical	24	10.5	Lindh et al. (2009)
<i>G. f. fuscipes</i>	Riverine	black square	21.6	10.5	Lindh et al. (2009)
<i>G. p. palpalis</i>	Riverine	black horizontal	54	21	Tirados et al. (2011)
<i>G. p. palpalis</i>	Riverine	black vertical	38	21	Tirados et al. (2011)
<i>G. f. quazensis</i>	Riverine	black horizontal	16	7.8	Tirados et al. (2011)
<i>G. f. quazensis</i>	Riverine	black vertical	6	7.8	Tirados et al. (2011)
<i>G. swynnertoni</i>	Savannah	blue horizontal	68.4	99.2	Mramba et al. (2013)
<i>G. swynnertoni</i>	Savannah	blue-black-blue horizontal	96.4	84.8	Mramba et al. (2013)
<i>G. swynnertoni</i>	Savannah	blue horizontal leg panel	31.6	35.3	Mramba et al. (2013)
<i>G. swynnertoni</i>	Savannah	blue vertical	-	-	No data
<i>G. swynnertoni</i>	Savannah	blue-black-blue vertical	-	-	No data
<i>G. pallidipes</i>	Savannah	blue horizontal	84.9	65.4	Mramba et al. (2013)
<i>G. pallidipes</i>	Savannah	blue-black-blue horizontal	79	69.6	Mramba et al. (2013)
<i>G. pallidipes</i>	Savannah	blue vertical	-	-	No data
<i>G. pallidipes</i>	Savannah	blue-black-blue vertical	-	-	No data

## 1.8. Perspective for improvement of visual baits for the tsetse population control

Previous work on the landing reaction of insects has suggested that there are at least two different visual stimuli for landing (Goodman, 1960, Braitenberg and Ferretti, 1966): the “expansion” of a pattern on the visual field of the insect’s compound eye and the variation in the total luminous flux from the visual pattern, a decrement of which elicits a landing reaction by the insect. Neurons that serve as brightness detectors and movement detectors are known in arthropods (Burr and Catton, 1960, Rowell, 1971, York et al., 1972). Electrophysiological recordings from the sub-oesophageal ganglion and cervical connective of *Musca domestica* have revealed the existence of units which integrate visual stimuli that elicit landing behaviour (light-off stimulus or the expansion of a spatial pattern) and those which cause inhibition of a landing (light-on stimulus or contracting pattern; Taddei-Ferretti and Perez de Talens (1973)). Furthermore, the landing response can be triggered in tethered flying *Drosophila melanogaster* using a black disk against a white background moving towards the fly (Vvitek, 1988).

It is clear that improving landing by insects on a visual object must take into account the property of the object to create a shadow. The interior of tsetse traps as seen through entrances must be sufficiently shadowed. The presence of interior black panels enhances decreasing brightness inside traps to encourage flies to enter (Green and Flint, 1986; Vale, 1982). All traps developed over decades were conceived with flies entering from a bottom opening before being attracted by the daylight coming from above through the white cone made of mosquito netting (Challier and Laveissière, 1973; Vale and Hargrove, 1979). Landing on the bottom of visual objects was also observed in the case of targets in the field by Vreysen et al. (1998). In fact, using sticky crossed panels horizontally and diagonally divided into blue–white parts forming, respectively, horizontal oblong and triangular patterns, landing positions of flies were recorded on crossed panels. The authors found most *G. austeni* landed on the bottom exterior corners of crossed panels irrespective of colour (white or blue). This confirms that the improvement of visual baits must take into account the propensity of tsetse to alight on the bottom parts of objects. The choice of this exterior landing site on crossed panels could be related to the concern of visual environmental control by tsetse. In fact, the more flies alight near the joining of panels the more they are losing their environmental visual control as the orthogonal panel covers a part of their visual field. Vreysen et al. (1998) also found that

the catch of *G. austeni* increases with increasing horizontal dimensions but not with vertical extensions of targets tested. These observations were already made by Vale (1974) for *G. pallidipes* where horizontal oblongs were found to be most attractive and to induce more landings. Some investigations have also been made for *G. f. fuscipes* and *G. tachinoides* under field conditions using targets 1 m<sup>2</sup> (square) and 1.5m<sup>2</sup> (horizontal oblong) in size vertically divided into blue and black parts and covered on both sides by adhesive film (Oloo et al., 2014). More males were caught on the bottom third of the blue and black portions of targets and females showed a preference for the top and bottom sections of the blue and black components of a same target (Oloo et al., 2014). Furthermore, analysis of the visual attractiveness and landing responses of tsetse flies from more recent studies shows that the perimeter-surface ratio of the visual object must be in a range of 6-8 to produce an efficient target (Tables 1.6, 1.7 and 1.8). If a deltamethrin-impregnated visual object meets all these conditions, an approaching tsetse would land on it to pick up the insecticide.

### **1.9. The situation of sleeping sickness in the Central African Republic**

The Central African Republic (CAR) is among the countries most affected by African trypanosomiasis and hosted 50% of affected persons in 1945 in French Equatorial Africa (Nguembi, 1982, Ngoumale, 1984). The CAR had declared more than 1000 new human cases per year since 2005. Four foci of trypanosomiasis are known (Bailly *et al.*, 1990; Mbelesso *et al.*, 2011; Fig. 1.9):

- The focus of Nola in the forest area in the south-west of the country;
- The focus of Ouham, in the north-west savannah area;
- The focus of Haut-Mbomou is the far east of the country;
- The focus of Lobaye, in the southern part of the country, is less important but deserves regular monitoring because it is close to the very active focus of the Equator region in the Democratic Republic of Congo.

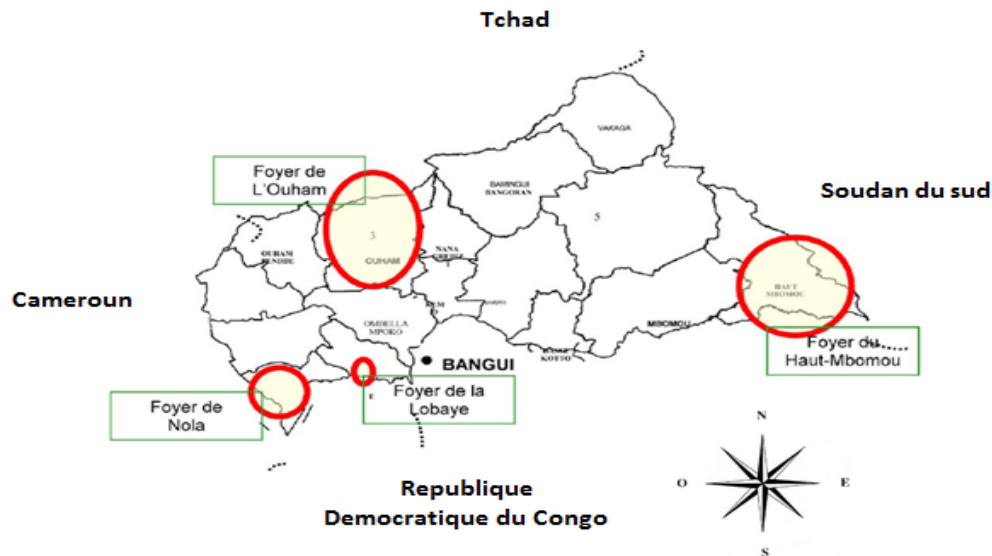

Fig. 1.9. Mains foci of human trypanosomiasis in the Central African Republic (CAR) (Mbelesso et al., 2011)

Three main riverine species exist in the CAR and are distributed as follows (Delas, 1972, Ezouan and Ferrera, 1973, Finelle et al., 1963):

- *G. p. palpalis*, only found in the Nola focus;
- *G. f. fuscipes* found everywhere in the country in forests and along forest galleries;
- *G. tachinoides* found in savannah zones in the north of the country.

Furthermore, the presence of *G. m. morsitans* and *G. m. submorsitans* has been reported in savannah zones (Rogers and Robinson, 2004).

In the 90s the government of CAR created a national programme against HAT. This programme aimed at the stabilization and progressive decrease in the number of recorded cases by active screening of the population, chemotherapy and the use of traps (biconical and monoconical) against tsetse (RCA, 1994). But this process was interrupted by different political crises, preventing the intensification of entomological surveys and consequently giving rise to an increase in disease incidence at the beginning of 2000 (Mbelesso *et al.*, 2011). The situation in CAR remains of concern as the climate favours the survival of tsetse vectors of trypanosomes for humans and animals. Some 68% of rural populations depending on agriculture, animal husbandry, fishing or hunting are most exposed to tsetse fly bites and, as a consequence, to Human African Trypanosomiasis (HAT) and Animal African Trypanosomiasis

(AAT) (RCA, 2008). Biconical traps are occasionally used for sampling tsetse populations in the focus of Nola while others remain inaccessible due to insecurity in the corresponding regions. The newer visual bait technologies (targets in a 2D configuration) against tsetse have never been used in the CAR.

### **1.10. Research interests and outline of the thesis**

Much remains to be done to eradicate trypanosomiasis. One method of tsetse control is the use of deltamethrin-impregnated traps and targets (Mangwiro *et al.*, 1999; Torr *et al.*, 1992). In this respect, efforts have been focused on the development of cost-effective visual targets by reducing their size and this is proving worthwhile for riverine tsetse (Lindh *et al.*, 2009; Esterhuizen, *et al.*, 2011; Rayaisse *et al.*, 2011; Tirados *et al.*, 2011; Mramba *et al.*, 2013; Kaba *et al.*, 2014; Tirados *et al.*, 2015). Such targets do not work for savannah tsetse. However, the installation of visual targets requires manpower. Poles required to be planted in the ground to support targets deployed in the field and in arid areas the soil is hard to dig. Poles are usually made of wood and therefore degrade after a few months so it is necessary to replace them. Further, smaller targets can be covered over by vegetation and become inoperative (Esterhuizen *et al.*, 2011a). In integrated control of tsetse, devices sometimes need to be moved within a site or focus according to the local tsetse population density (Sciarretta *et al.*, 2005; Sciarretta *et al.*, 2010). It is necessary to develop cost-efficient, easy deployable and standardized visual baits to facilitate tsetse control.

Interest by tsetse for shadows had been extensively exploited to improve tools for tsetse control. Some improvements in devices were performed based on the tendency for flies to alight on black portions of objects (which symbolize shadow) inside traps and on targets (Green and Flint, 1986; Vale, 1982; Green, 1989; Vale; 1993). Few studies (Vreysen *et al.*, 1996, Vreysen *et al.*, 1998) have examined the possibility to provide a 3D component to simple 2D targets. The main goal of the present work is to develop new 2D tools equipped with a 3D component based on the horizontal diurnal resting sites of all tsetse groups. Since we suspected that tsetse can “see” in the dark (Fig. 1.4), investigations have been made under light and dark conditions to assess the genesis of fundamental survival strategies of tsetse related to their resting sites (Chapter 2). Resting site characteristics of tsetse were used to improve landing responses of savannah tsetse group, especially *G. pallidipes*, on a blue small target in a wind tunnel taking into account the behaviour of flies in flight in the presence of

such a target (Chapter 3). As objects used for tsetse control are impregnated with deltamethrin, the question of the efficacy of textiles to retain the insecticide under field conditions is also treated (Chapter 4).



## **2. The genesis of fundamental survival strategies in tsetse: a laboratory study**

## Abstract

The basis of the survival strategy of tsetse flies consists in the exploitation of vegetation as refugia (cool, humid and shady places) where horizontal branches constitute preferred resting sites. Tsetse are considered as diurnal insects even though night activity has been reported in some species. Control and eradication of tsetse require a solid knowledge of their behaviour and ecology. In this chapter, negative geotaxis to resting sites by freshly-emerged *G. pallidipes* was assessed under light (photophase) and dark (scotophase) conditions in the laboratory. Results show that, in the photophase, freshly-emerged *G. pallidipes* stayed immobile for 15-30 min around the emergence dish before flying away. In the scotophase, *G. pallidipes* walked rapidly in the seconds following its emergence to climb vertical bars disposed around the emergence dish or, when flies missed such the bars, they climbed the wall of the cage. When black bars were suspended horizontally in the cage, freshly-emerged and older *G. pallidipes* flew to them in the scotophase. An estimation of the residual light in the scotophase indicated illuminance of at most 10 times below that reported for a night with an overcast sky. Criteria of selection of resting sites by *G. pallidipes* were also investigated in the photophase. Older (5-7 day-old, fed once) *G. pallidipes* preferred the horizontal suspended bar of smaller diameter (1 cm) to one with the bigger diameter (2 cm) presented simultaneously whereas teneral flies (0 day-old) rested in equal number on both bars. Assessing the visual resolution of *G. pallidipes* by optomotor and electroretinography responses showed that the temporal resolution of the eye of 7 day-old *G. pallidipes* (fed once) was 1.3 – 1.5 time higher than that of 1 day-old teneral flies. These findings clearly show that (1) *G. pallidipes* is able to find a perch off the ground in the dark, an adaptation that is an innate behaviour in this species, and (2) the selection of resting sites is probably related to the degree of visual resolution of flies. These results are discussed in the context of survival strategies in tsetse.

**Keywords:** tsetse fly, emergence, geotaxis, resting sites, visual resolution, optomotor, electroretinography.

## 2.1. Introduction

Tsetse flies have a low rate of reproduction (Carey, 2001) and such organisms have to develop all possible strategies for its species survival. The metabolism of tsetse, like most of insects, is influenced by abiotic factors such as temperature and humidity. Oxygen consumption and feeding frequency increase with temperature whereas flight duration decrease in male of *G. m. morsitans* (Bursell and Taylor, 1980). To limit such metabolic cost tsetse prefer to rest in refuges (shady, cold and humid microhabitats). Tsetse of different sexes, species, nutritional states and pregnancy stage are affected to different degrees when temperatures rise above 32°C (Vale, 1971, Hargrove, 1999, Hargrove and Packer, 1993, Torr and Hargrove, 1999) and those most affected, especially small individuals whose pupae were produced from fewer meals and pregnant females will first enter refuges (Hargrove, 1999, Torr and Hargrove, 1999). Vegetation provides refuge to tsetse to limit metabolic cost (Hargrove, 1994) and serves as larviposition, emergence and resting sites (Swynnetorn, 1936; Nash, 1939; Harley, 1954). Undersides of horizontal branches are the most preferred diurnal resting sites besides twigs, tree trunks and rot holes (Pilson & Leggate, 1962; Okoth & Kopaata, 1987; Abdurrahim, 1971). At dusk and night they move on upper sides of leaves (McDonald, 1960, Spielberger and Barwinek, 1978). The emergence of tsetse is temperature-dependent and freshly-emerged fly, in diurnal conditions, stays generally immobile at the emergence site for 15-30 min before flying away (Zdárek and Denlinger, 1992). This immobility is rendered possible since adults normally emerge into refuges where risks from desiccation and high metabolic rate due to extreme temperatures are limited. The behaviour of freshly-emerged tsetse in the dark is unknown. However, night activity by *G. austeni* and *G. brevipalpis* has been reported (Moggrige, 1948, Kappmeier, 2000a) and *G. pallidipes* can also be active during moonlit nights (Vanderplank, 1941) when both sexes were found active (Chorley and Hopkins, 1942). We hypothesized that adult tsetse which emerge at night might adopt an innate survival behaviour to find a suitable place to complete metamorphosis and that propensity of tsetse to find suitable objects in shady places could be related to the resolving power of their visual system. In this study, the behaviour of freshly-emerged and older *G. pallidipes* in relation to bars presented at different orientations in a cage under light and dark conditions was observed to assess the role of the vision in the dark in the genesis of survival strategies of tsetse. Factors influencing the choice of horizontal bars as resting sites under light conditions were also investigated. We provide evidence that both freshly-emerged and mature tsetse are

able to find suitable resting sites in the dark and that mature tsetse clearly possess a higher visual resolution.

## 2.1. Materials and Method

### *Tsetse flies*

*G. pallidipes* pupae were obtained from the International Atomic Energy Agency (Siebersdorf Laboratories, Austria). Adults emerged into cotton netting cages (1 mm mesh, 25 × 15 × 15 cm), in an environmental cabinet at 25°C, 80% relative humidity (RH) under high frequency (1 KHz) fluorescent lighting (for details see below) with 8 h photophase, 1 h light ramps at dawn and dusk and 14 h scotophase. Flies were fed on day 3 with heparinized (1000 UI/ml) bovine blood, collected at a local slaughterhouse, through a silicone membrane at 35-37°C (Langley and Maly, 1969). In the horizontal bar experiment below, fed flies are 5-7 day-old, i.e. fed on day 3 and starved for 2-4 days. Afterwards, flies were maintained under the same conditions as above and fed every five days during one month for electroretinogram recordings.

### *Negative geotaxis in freshly-emerged G. pallidipes*

We hypothesized here that freshly-emerged tsetse might show negative geotaxis to find a refuge above ground to complete metamorphosis. To test this, two wooden round bars 1 cm in diameter painted matt black (Dupli-color®, MOTIP DUPLI GmbH, Hassmersheim, Germany) were joined to form a T providing vertical and horizontal resting sites and called “T-bars” here (Fig. 2.1a). Three T-bars of different heights (13.5, 19.5 and 25.5 cm) and with different spans (12, 18 and 24 cm) and 16 vertical bars 1 cm diam and 25.5 cm high (called upright bars hereunder) were inserted into a 34 cm square plywood base 1.5 cm equidistant from one another (Fig. 2.1a). In this manner the vertical and T-bars formed a 15 cm diameter circle around the emergence dish (8 cm in diameter, 1.5 cm deep) set in a central trough flush with the plywood and containing *G. pallidipes* pupae placed on cotton wool. A Plexiglas cage (55 x 35 x 35 cm) with two holes was superimposed on the plywood base containing the bars (Fig. 2.1b). The hole in the cage ceiling was covered by a transparency sheet of cellulose acetate for Opra™ C printer (LEXMARK, Greenwich, Connecticut, USA) (Opra C, LEXMARK, Greenwich, Connecticut, USA) and that on the side by mosquito netting. An infrared (IR) light source (Helios/L-IR series, GEUTEBRUCK GmbH, Germany) with a peak of transmittance at 950 nm (Fig. 2.1c), i.e. beyond to the spectral sensitivity range of tsetse (300-700 nm; Green and Cosens, 1983) and an IR-sensitive black and white charge-coupled device camera (CCD WV

BP310; Panasonic, Osaka, Japan) equipped with a TV zoom lens (TARCUS TV lens, 8 mm, F1.3 mm, Tokyo, Japan) were placed 25 cm above the cage ceiling. To monitor the movement of freshly-emerged flies the camera was connected to Ispy software (version 6.3.3.0, [www.ispyconnect.com](http://www.ispyconnect.com)) on a personal computer and recordings were made continuously over 24 hours. During the photophase the high frequency fluorescent tubes positioned 45 cm above the cage ceiling were set to provide an intensity of ca. 300 lux on the emergence dish as measured by a lux meter (Reed ST-8820 Environment Meter, ELV Elektronik, Leer, Germany) to simulate shaded conditions. During the scotophase the IR lamp was used. The temperature of bars was checked using a non-contact IR thermometer (Lutron co., LTD; Taipei, Taiwan) and was not influenced by the IR light source. All the setup was installed using disposable gloves to avoid any human deposits on materials. Two different batches of pupae were used. At emergence the time spent by a freshly-emerged fly before leaving the emergence dish was recorded. The position of the freshly-emerged fly was recorded on the emergence dish, around the emergence dish but inside the circle (15 cm diameter) delimited by upright and T-bars (Fig. 2.1a), on bars themselves or elsewhere in the cage. In these experiments emergence of 102 and 288 *G. pallidipes* was recorded, respectively, during the photophase and scotophase.

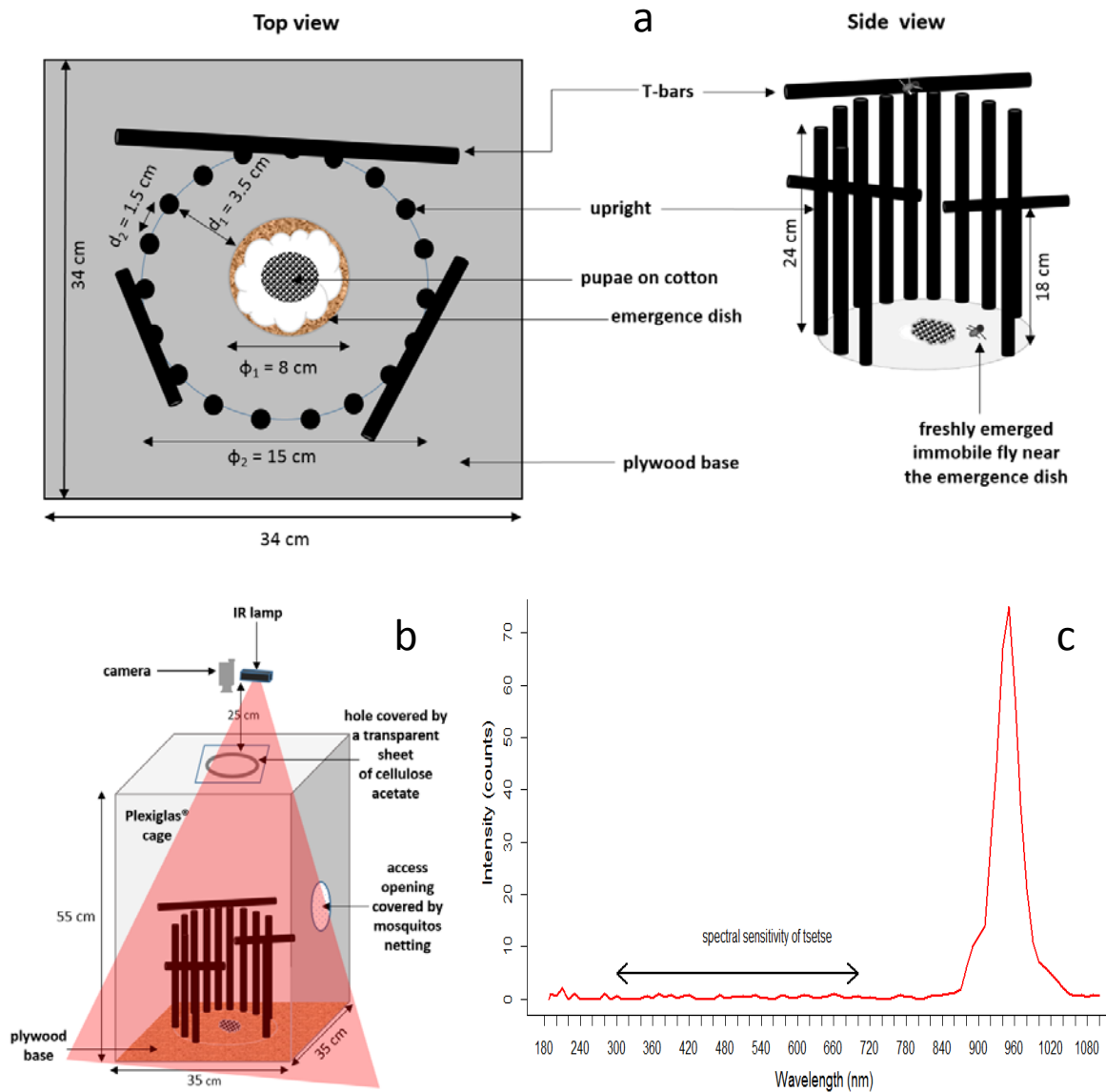

**Fig. 2.1.** (a) Top and side views of the set up (not to scale) used for the assessment of negative geotaxis in freshly emerged *G. pallidipes*:  $d_1$  distance between bars and emergence dish,  $d_2$  distances between bars,  $\phi_1$  diameter of emergence dish,  $\phi_2$  diameter of the circle formed by bars around the emergence dish. (b) Complete view of the setup with the Plexiglas cage and the positions of the camera and the IR lamp with its transmittance spectrum (c) as measured by a high-resolution optic spectrometer (HR2000 Series, Ocean Optics, Inc., Florida, USA).

### Horizontal suspended bar experiment

Experiments were made to test the hypothesis that freshly-emerged tsetse can fly to horizontal suspended bars as resting sites in the dark and, subsequently, preferences for bars of different diameters and forms under different lighting conditions were tested. For this, wooden round bars 16 cm long and 1 cm diam, 16 cm long and 2 cm diam, and 24 cm long and 1 cm diam painted matt black as above were tested as resting sites. To test whether the form

of the bar could influence resting site preference, an equilateral triangular bar (called the triangular bar hereunder) 24 cm long and 1 cm high was also tested. Bars were suspended in parallel by 0.15 mm diameter transparent nylon fishing line in a cage with netting on a white plastic frame (80 cm long, 45 cm deep and 45 cm high; BugDorm-4180F, MegaView Science, Taichung, Taiwan). The bars were hung at 20 cm from the floor and were separated from each other by 20 cm (Fig. 2.2). Bar positions were interchanged daily in all experiments. The floor of the cage was covered with black cloth (100% cotton, 470 g/m<sup>2</sup>; Gubser Textile AG, Schlieren, Switzerland) showing no reflectance below 660 nm as measured with Datacolor Check Spectrophotometer (Datacolor AG, Dietlikon, Switzerland; Fig. 2.2). The cage was placed under high frequency fluorescent lighting positioned 50 cm above its ceiling, providing a light intensity of ca. 2000 lux on the cage floor whereas during the scotophase the IR lamp described above was used. The environmental cabinet was at 25°C, 80% RH. All the setup was installed using disposable gloves to avoid any human depositions on bars.

For experiments with teneral flies, i.e. flies that had not yet taken the first blood meal, mature pupae were placed inside the cage at the end of the photophase and recordings of flies' positions on bars started for 24 h. Pupae with pharate adults were removed after 1 h into the subsequent photophase with freshly-emerged flies staying in the cage for recordings. As flies emerged directly into the cage both sexes participated in these experiments and their numbers were counted at the end of recordings permitting to assess recruitment to bars as a function of fly density in the cage. Such flies were not used again. For 1-2 day-old teneral and 5-7 day-old fed tsetse, 30 flies that had emerged into the rearing cages were introduced into the test cage just prior to the scotophase and fly positions on bars were recorded 5 min every hour over 24 hours. These experiments were repeated at least 15 times for all groups of flies tested (0 day-old, 1-2 day-old and 5-7 day-old flies). Moreover, as fed *G. pallidipes* preferred the smaller diameter bar for resting it was hypothesised that the resting behaviour of tsetse is related to input from commonly occurring environmental visual stimuli of a certain size and visual aspect. To test this, a black bar (24 cm long, 1 cm wide and 1 cm high) and a black rectangular parallelepiped (24 cm long, 6 cm large and 1 cm high) made of black insulating foam were both suspended inside the test cage in the same manner as above. The parallelepiped was constructed such as its width was 6 fold wider than the square bar but of the same height. Thirty 1 day-old *G. pallidipes* were used under the same conditions as above

per repetition, i.e. flies were introduced just prior the scotophase but here, resting positions of flies on the square black bar and the black parallelepiped were recorded 1 h after onset of the subsequent photophase. This experiment was repeated 8 times. *G. pallidipes* positions were monitored by two webcams (HD C270, Logitech, Suzhou, China) camouflaged with aluminium paper and placed at opposite corners on the floor and on the top of the cage to record fly positions on both the under and upper sides of suspended objects. Recordings at one hour intervals were facilitated by Ispy software (version 6.3.3.0, [www.ispyconnect.com](http://www.ispyconnect.com)) installed on a personal computer.

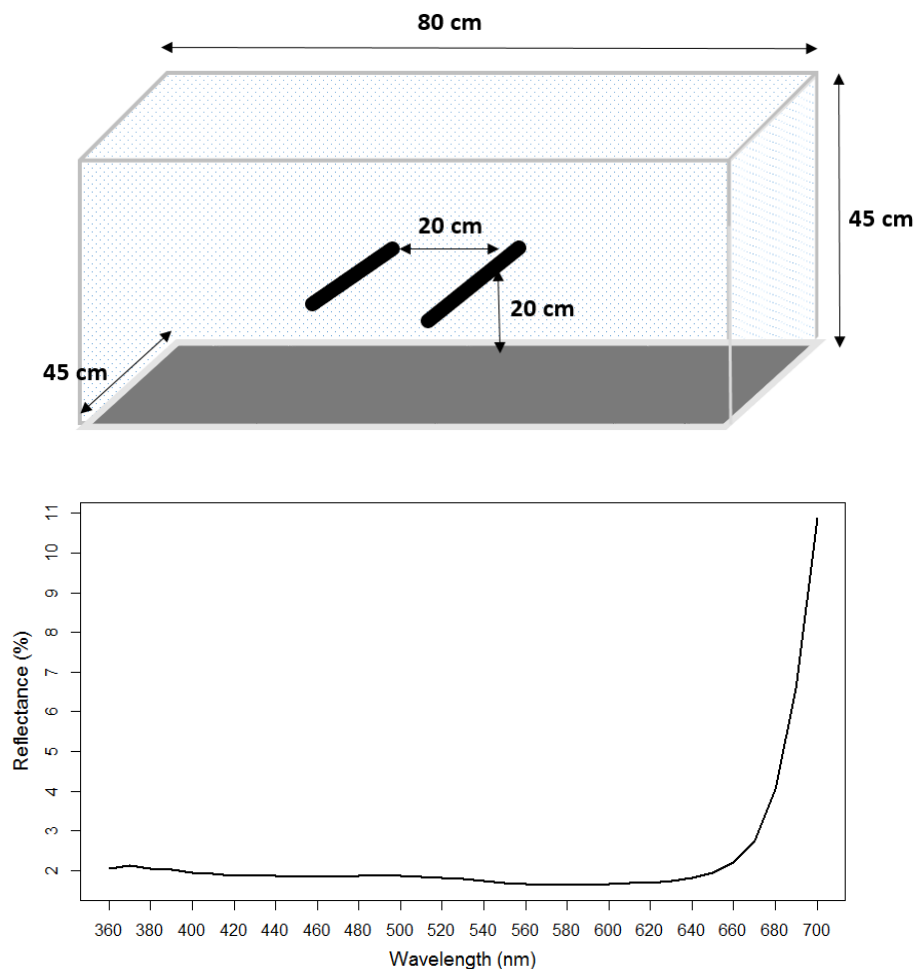

**Fig. 2.2.** **Above** two suspended parallel horizontal bars in the white netting cage with white plastic frame and black cloth covering the floor; **below** reflectance spectrum (measured with Datacolor Check Spectrophotometer, Datacolor AG, Dietlikon, Switzerland) of the black cotton cloth used to cover the floor of the cage.

Considering how recruitment to horizontal bars rose during the first hours of the scotophase for both teneral and fed flies we suspected tsetse to exploit the residual

phosphorescence from the fluorescent lamps in the environmental cabinet to locate bars in the scotophase. To test this, thirty 1-2 day-old *G. pallidipes* were transferred into the test cage 1 hour before the end of the photophase and the number of tsetse on bars was recorded at the end of the photophase and during the onset of the subsequent scotophase. Just after lights off the experimenter entered the cabinet and hid the high frequency fluorescent lamps with black cardboard, leaving only the IR lamp turned on for video recording. This experiment was repeated 6 times.

#### *Estimation of the residual light in the experimental cages during scotophase*

The contribution of residual light, i.e. the phosphorescence from fluorescent tubes in the environmental cabinet after lights off was suspected as it was found that hiding fluorescent tubes stopped recruitment of *G. pallidipes* to horizontal suspended bars during the scotophase. The intensity of residual light was estimated using a photomultiplier (PM) tube (XP2020, ET Entreprises, Uxbridge, England) and a lux meter (Reed ST-8820 Environment Meter, ELV Elektronik, Leer, Germany). Measurement was made by Dominique Schenker, Faculty of Science Technical Support Service, University of Neuchâtel. A PM is a vacuum tube consisting of an input window (photocathode), focusing electrodes, an electron multiplier system consisting of dynodes and an anode usually sealed inside an evacuated glass tube (Fig. 2.3A). Light entering a photomultiplier tube produces an output signal through the following process (Hamamatsu Photonic, 2006; Fig. 2.3A):

1. Light passes through the input window and reaches the photocathode;
2. Light excites the electrons in the photocathode which are emitted into the vacuum (external photoelectric effect). Such electrons are called photoelectrons;
3. Photoelectrons are accelerated and focused onto the first dynode where they are multiplied by means of secondary electron emission. This secondary emission is repeated at each of the successive dynodes;
4. The multiplied secondary electrons emitted from the last dynode are finally collected by the anode which transmits the electron current pulses (gain) to an external circuit (counter).

Light sources in the environmental chamber (2.5 x 2.5 x 2.2 m) are made of two metal boxes (133 cm long, 73 cm wide and 7.5 cm high) whose inner walls were covered by

aluminium plates. The light boxes hung from the ceiling on the two opposite long sides of the environmental chamber. Each of the two light boxes housed 133 cm long eight fluorescent tubes (Osram L 36W/840 Lumilux) and were covered on the underside by an acrylic glass plate to scatter light (Fig. 2.3B). The PM tube with an aperture  $d_1 = 16$  mm was placed inside the cage used for experiments with horizontally suspended bars such that the aperture was 70 cm under the centre of a light box. The PM tube was powered by a high voltage power supply (2.3 kV; Keithley model 247, Beaverton, USA) and was connected to a counter (Agilent 53131; San Diego, USA) that displayed the number of detected photons every 5 s. The counter was set to high sensitivity, the trigger level of the counter was 20 mv at an impedance of 50  $\Omega$ . The background noise of the PM equalled 15 photons/s measured with its aperture covered with black opaque vinyl electric tape (Scotch<sup>®</sup>, 3M Electrical; Austin, USA).

A lux meter was used to calibrate the PM. As the PM works only at very low light levels (maximum  $10^{-4}$  lux) the aperture was reduced to  $d_2 = 200$   $\mu$ m. The calibration was done within an illuminance range of 0.1 – 1 lux. Values measured in parallel with the lux meter and the PM were used to fit a polynomial function of calibration (Fig. 2.3C). Numbers of photons detected during the scotophase using the large aperture of the PM were normalized using the PM aperture ratio  $d_1/d_2 = 6400$  as denominator and converted into illuminance values (lux) by extrapolation using the polynomial function. The emission spectrum of the fluorescent tube was considered to be stable during the scotophase. The transmission spectrum of the colour filter of the lux meter follows the CIE photopic luminosity function (CIE, 1951) and transmits light in the 400 - 600 nm range (Fig. 2.4), corresponding to the spectral sensitivity of tsetse (Green and Cosens, 1983). Measurements and calibrations were made at 25°C and 50% RH.

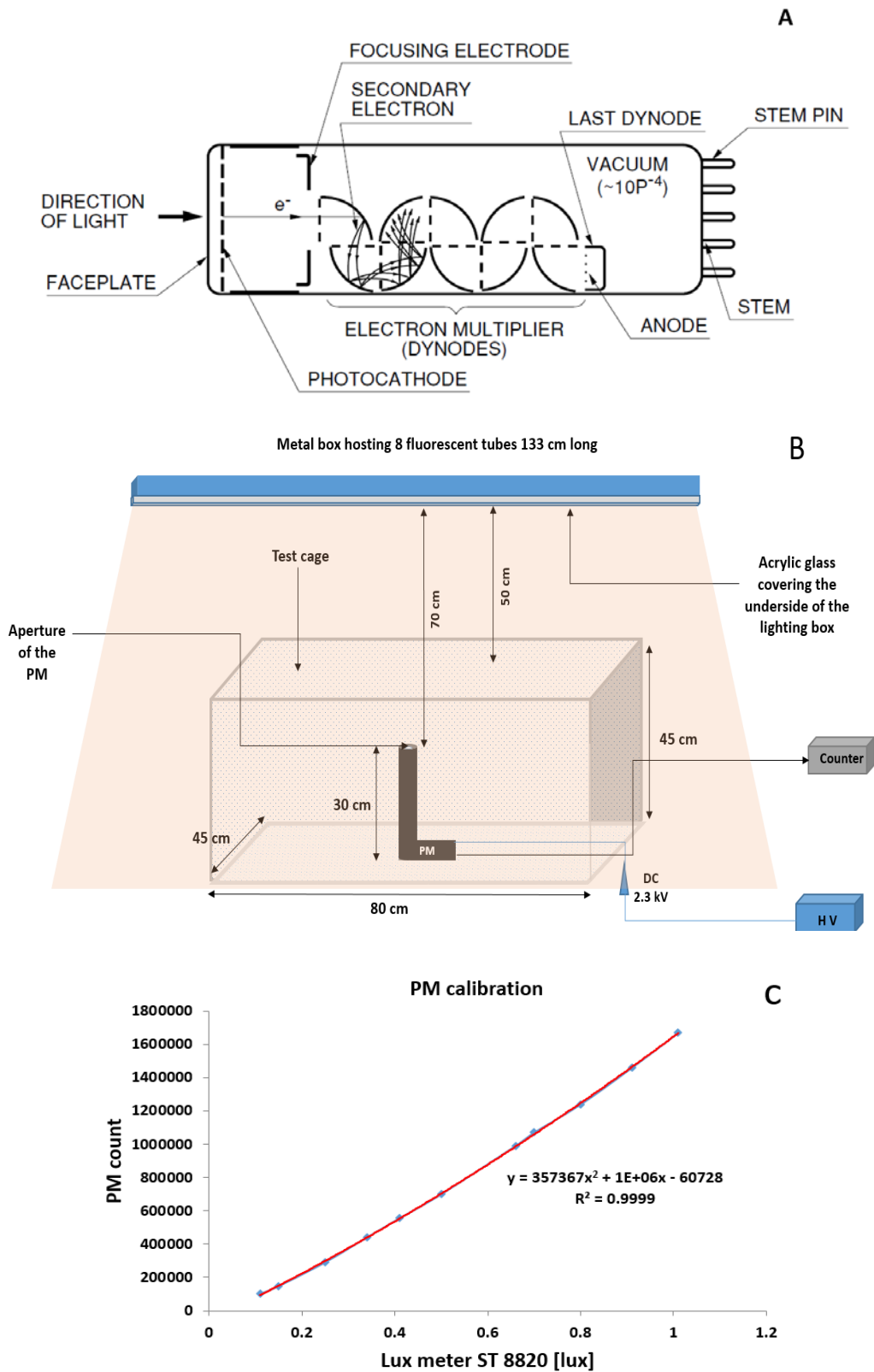

**Fig. 2.3.** (A) Structure of a photomultiplier tube (Hamamatsu Photonic, 2006). (B) Setup for the measurement of the residual phosphorescence from the light box with 8 fluorescent tubes with the photomultiplier tube (PM), the high voltage power supply (H V) and the current pulse counter. (C) Calibration of the PM (PM relative count of photons as a function of the relative luminosity displayed by the ST 8820 lux meter).

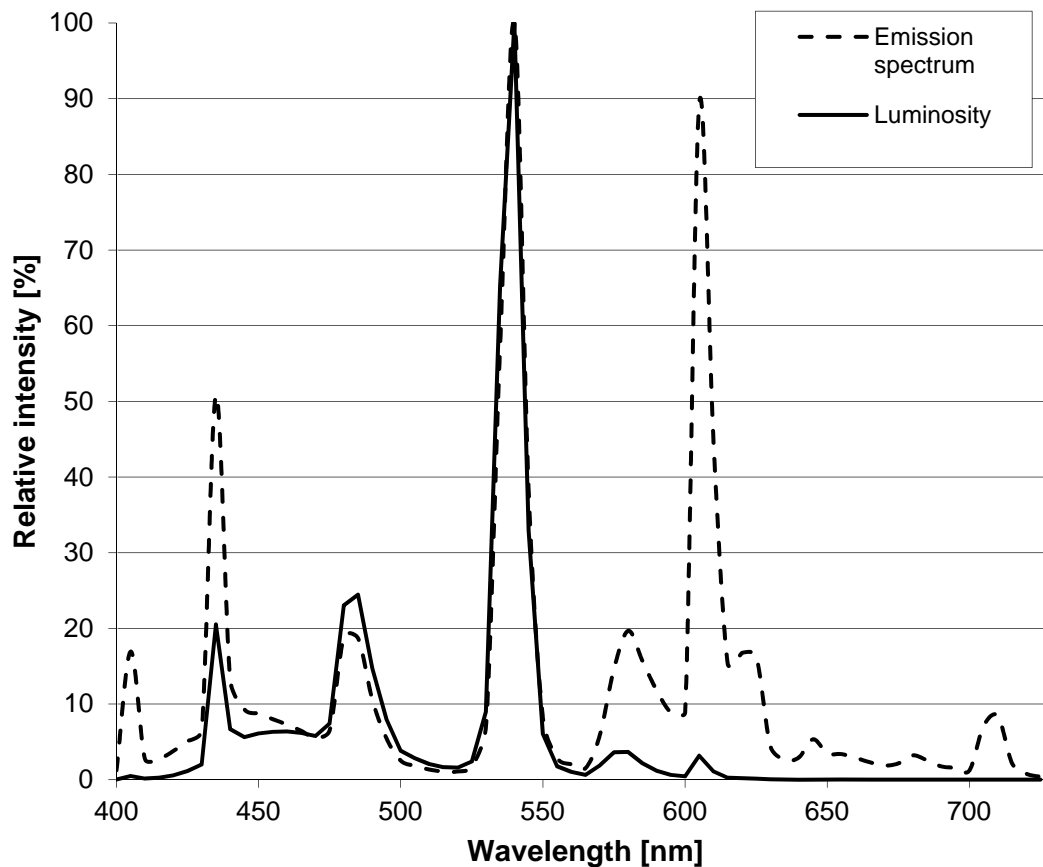
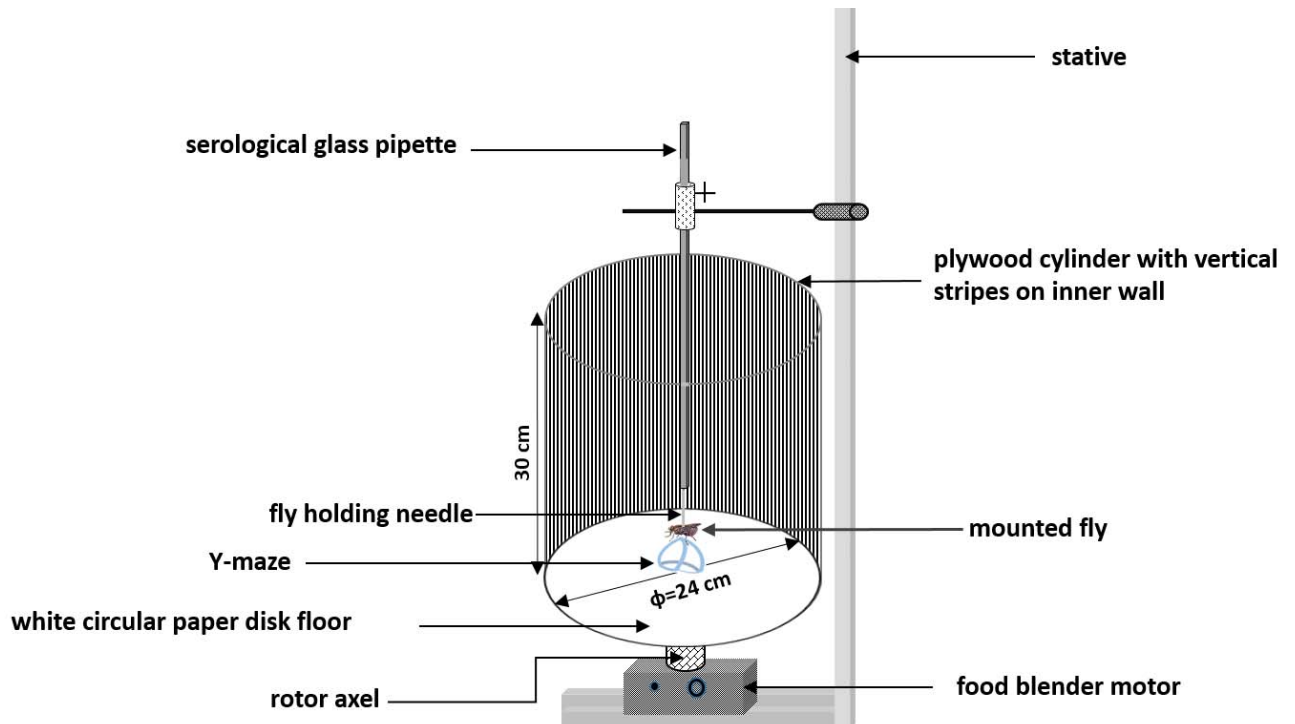

**Fig. 2.4.** Emission spectrum (dotted line) of the fluorescent tube that provided light in the environmental cabinet where horizontal bar experiments were made, and its luminosity (solid line) was calculated using the CIE 1951 luminosity function corresponding to the spectrum of light passing through the colour filter of the ST 8820 lux meter used to calibrate the photomultiplier for the estimation of residual phosphorescence during the scotophase.

#### *Testing *G. pallidipes* visual resolution as a function of age*

The size of horizontally suspended bars influenced the choice of resting positions by older and fed *G. pallidipes*, but did not have any effect on the choice by teneral tsetse. This suggested differences in visual resolutions between these two tsetse groups. The temporal resolving power of their compound eyes was then compared by both behaviour and electrophysiology. The flicker fusion frequency (FFF) of the eyes was compared behaviourally using the optomotor response where the fly reacts to the perception of movement by making a compensatory turning response using the method of Hassenstein (1951). For this a plywood cylinder 24 cm in diameter, 30 cm high fixed on the rotor of a food blender and bearing 180 black vertical stripes 2 mm wide and 2 mm apart printed on white paper on its inner walls (Fig.

2.5). The width of stripes was chosen following Turner and Invest (1973) such that at its minimum resolving power (based on the value of  $3.4^\circ$  for the lateral ommatidia of *G. morsitans* in the traverse plane) the tsetse compound eye covered at minimum a field 6 mm wide (three stripes) from a position at the middle of the cylinder. The fly was fixed by its mesonotum (dorsal plate) to the round head of a needle (3.75 cm long, 0.5 mm diam) using a quick-drying paper glue. The needle tip was then fixed inside the drawn out 1 mm tip diameter of a 5 ml glass serological pipette (36 cm long, 1 cm diameter) using plasticine. Mounted flies were dark adapted for 60 min in an environmental cabinet (25°C, 75% RH) where tests were conducted. High frequency lighting (1 kHz, described above) placed 80 cm above the cylinder provided illumination of 2000 lux on the floor of the cylinder. The serological pipette with the attached fly was fixed vertically to a stative from above such that the pipette was positioned in the centre of the cylinder and the fly positioned at 3 cm above the floor. A Y-maze sphere (Hassenstein, 1951) 4 cm in diameter and 40 mg in weight made of sky-blue paper strips 4 mm in width hung from the fly by its legs. Each fly was tested successively at increasing frequencies of moving stripes from 50 to 350 Hz in steps of 50 Hz. Two responses were recorded: when the fly moved the Y-maze opposite to the direction of the stripe movement or walked to one of the Y-maze crossings and turned in the direction of the movement the response was recorded as positive (the fly compensated for stripe movement by turning its body in the direction of the stripe movement with its legs turning the Y-maze in the opposite direction); when the fly moved the Y-maze in the direction of the stripe movement or walked to one of the Y-maze crossings and turned opposite to stripe movement the response was recorded as negative. Each fly was tested with five moving stimulations lasting 15 s each with 15 s pauses per frequency. Eight 1 day-old teneral and eight 7 day-old flies fed once and starved for 4 days were tested providing a total of 40 recordings per frequency for each group of flies (teneral or fed). The frequency from which 50% of responses were positive was considered as the FFF.



**Fig. 2.5.** Scheme of the device used for testing the optomotor reactions of *G. pallidipes* (after Hassenstein, 1951).

The electroretinogram (ERG) was used to compare the FFF of teneral and fed *G. pallidipes* (Agee, 1971). This allows measurement of electrophysiological responses of an insect's compound eye receptor cells to light stimuli. The spectral sensitivity and FFF of *G. m. morsitans* has already been tested using the ERG (Miall, 1978; Davis & Gooding, 1983) whereas Green and Cosens (1983) established the spectral sensitivity in this species over the range 300 - 700 nm using the ERG. The ERG setup was mounted by Drs. Balázs Bernáth and Adam Egri, Laboratory of Animal Physiology, University of Neuchatel during the course of my thesis research and spectral sensitivity of *G. pallidipes* recorded by these researchers over the 300 - 700 nm range using the setup (unpublished data) is very similar to that recorded for *G. m. morsitans* by Green and Cosens (1983). To record the ERG, a fly were immobilized inside a plastic 2 ml microtube that was placed on ice for 3 min and was then placed inside a 1 ml plastic pipette tip (Sherwood Medical Industries, Dublin, Ireland) in such a way that the head and the thorax protruded (Fig. 2.6). The head, mouthparts and thorax were fixed to the opening of the pipette tip with melted beeswax. To prevent desiccation during ERG measurements, a piece of wet cotton was slipped into the pipette tip behind the prepared fly and the RH of the dark room where ERG recordings were made was held above 60%. Flies were dark adapted for 90 min in a humidified plastic box (7.5 cm x 6.5 cm x 5 cm) at 90-100%

RH and  $23^{\circ}\text{C}\pm 1$ . Glass capillaries (2 mm outer diameter with a drawn out tip of 1  $\mu\text{m}$  diameter) pulled with an Ealig electrode puller (model No. 50-2013) were used as measuring and reference electrodes and were filled with 100 mM KCl. Prior to ERG recordings made in the dark, the preparation was positioned under a stereo microscope and red illumination ( $\lambda > 600$  nm) in order to minimize light adaptation. The tip of the reference electrode was inserted into the centre of the head through the fronto-lateral region of the right compound eye and the measuring electrode was inserted into the fronto-lateral region of the left compound eye to a depth of 60 - 100  $\mu\text{m}$  beneath the level of the cornea lenses. The measuring electrode contained a chloridized silver wire that was connected to an amplifier (AM 92, Syntech, Hilversum, The Netherlands) via a preamplifier (X10 Syntech). The output signal of the amplifier was recorded by an IDAC-2000 multiplexer (Syntech) which was connected to a Dell laptop computer running the neurophysiological analysis software Autospike (version 3.0, Synthec; Fig. 2.6). Light stimuli were produced by a white light-emitting diode (LED, L5-W601 STD, SLOAN Precision Optoelectronics, Basel, Switzerland) connected to a remote controllable custom-developed stroboscope running on an Arduino UNO development board (<http://arduino.cc/en/Main/ArduinoBoardUno>, date last visited 06.06.2016). The stroboscope was controlled by the output control function of Autospike through the IDAC-2000. The stroboscope LED was placed 10 cm distant from the eye in the equatorial fronto-lateral plane (Fig. 2.6). The basic stimulus consisted of a 1 ms light flash, independent of the frequency of stimulation. To determine the FFF, stimuli consisted of these 1 ms flashes repeated for 3 s and separated by 5 s dark periods. Flash rates were tested in steps of 20 Hz between 15 to 105 Hz and in steps of 5 Hz between 105 Hz to 350 Hz. Measurements were performed in the AC mode of the amplifier that facilitated the determination of the response amplitudes in millivolt (mv) using Autospike. The frequency at which the ERG amplitude merged with the noise (ca. 0.1 mv) was considered as the FFF.

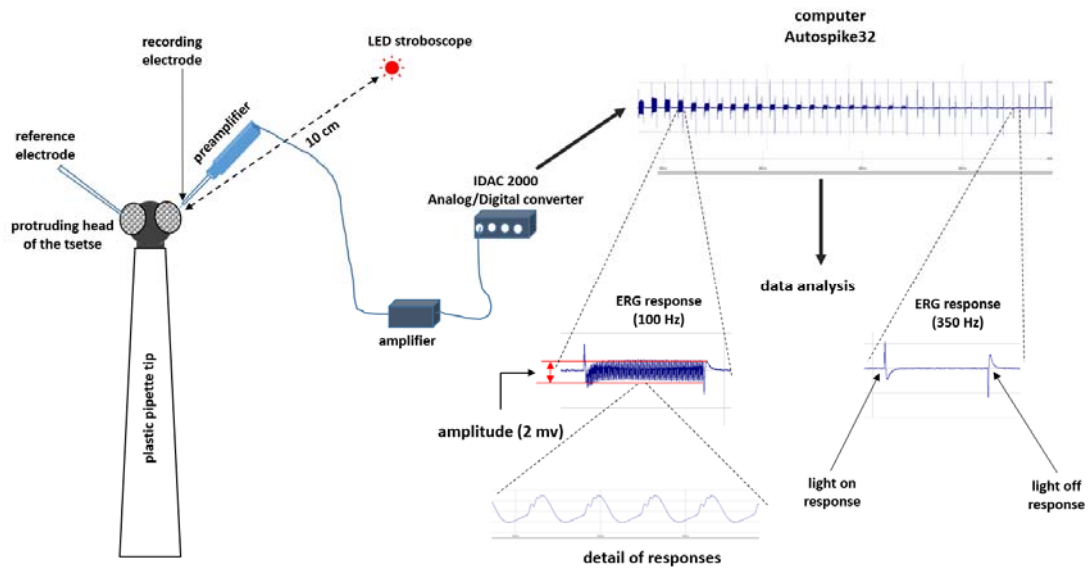

**Fig. 2.6.** Scheme of the set up used for ERG recordings and data analysis.

### Statistics

The proportion of freshly emerged tsetse that climbed up vertical bars and the proportion of flies that stayed immobile on the emergence dish, immediately around the dish and that walked past the bars without climbing up were compared using a generalized linear model (GLM) with the errors distribution of the binomial family. The exact binomial test was applied to determine the probability for a freshly-emerged *G. pallidipes* to climb up bars following the Bernoulli distribution. The Chi-square test was used to compare the observed proportion of flies that climbed up bars *versus* the expectation to determine whether meeting a vertical bar by a freshly-emerged fly was a coincidence. The choice of horizontal bars by *G. pallidipes* as a function of fly nutritional status, bar length, diameter and shape was analysed using a GLM with the errors distribution of Poisson family, or quasipoisson family when re-fitting the model was necessary owing to over dispersion of data. When a simplification of the model was needed each step was controlled by a deviance analysis following a Chi-square distribution (Crawley, 1993). The recruitment to bars as a function of the number of flies in the cage was analysed by a GLM with the errors distribution of Gamma family as variance was not homogeneous following the Bartlett test. The proportion of tsetse that showed a positive optomotor response was analysed with a linear mixed effect model by modelling the nutritional status and the sex as fixed effects whereas stripe frequency of movement and successive flies (1 to 8 for each stripe movement frequency) were modelled as random effects. The GLM with Poisson errors distribution was used to compare FFF measurements recorded

using ERG. All statistical analyses (level of significant 0.05) and all figures were generated using R software version 3.2.2 (R Core Team, 2016).

## 2.2. Results

### *Negative geotaxis in freshly emerged G. pallidipes*

Behaviour of freshly emerged *G. pallidipes* was observed in order to assess the propensity of flies to find a refuge above the ground. The *G. pallidipes* photophase: scotophase emergence ratio was 0.94. During the photophase, respectively, 42% and 48% of freshly emerged tsetse remained immobile on the emergence dish and immediately around it. But this 6% difference was not significant ( $n = 102$  flies, GLM with binomial errors,  $P = 0.1$ ; Fig. 2.7a and b). The remaining 7% and 3% of flies, respectively, climbed up the bars and walked past the bars from the total of 102 flies observed (Fig. 2.7b). By contrast, some 40% of flies that emerged during the scotophase climbed up the bars, 32% walked out of the circle delimited by the bars, 16% remained immobile around the emergence dish and the remaining 12% remained immobile on the dish (Fig. 2.7b). In the scotophase the proportion of flies that climbed up the bars was high compared to the proportion that stayed on the emergence dish ( $n=288$  flies, GLM with binomial errors,  $P<0.0001$ ; Fig. 2.7b) and that walked off the emergence dish but became immobile near it ( $P<0.001$ ). No difference was found between the proportion of flies that climbed up bars and those (32%) that walked past them in the scotophase ( $P=0.13$ ). Considering only those that walked as far as the bars, i.e. flies that climbed up bars and those that walked past them, the probability for a freshly emerged fly to climb up bars in the photophase was less than 0.02 (exact binomial test following the Bernoulli distribution,  $P=0.9$ ,  $n=102$  flies) whereas the probability rose to 0.53 in the scotophase ( $P<0.0001$ ,  $n=288$  flies). In the photophase, 90% of freshly-emerged immobile tsetse needed 15-30 min after emergence before flying to bars or to the walls of the cage ( $n = 90$  flies, Fig. 2.7c). In the scotophase, more than 84% of freshly-emerged tsetse immediately walked to the bars or past them within 20 s ( $n = 208$  flies; Fig. 2.7d). The proportion of flies that climbed up bars and rested vertically halfway up with their heads up was equal to that of flies that reached the top of the vertical bars or the upper sides of the horizontal component of T-bars (Fig. 2.8). No fly was found resting on the undersides of the horizontal component of T-bars. Negative geotaxis was observed only for flies that walked past bars during the scotophase when 78% of flies ( $n=99$  flies) climbed up the walls of the cage.

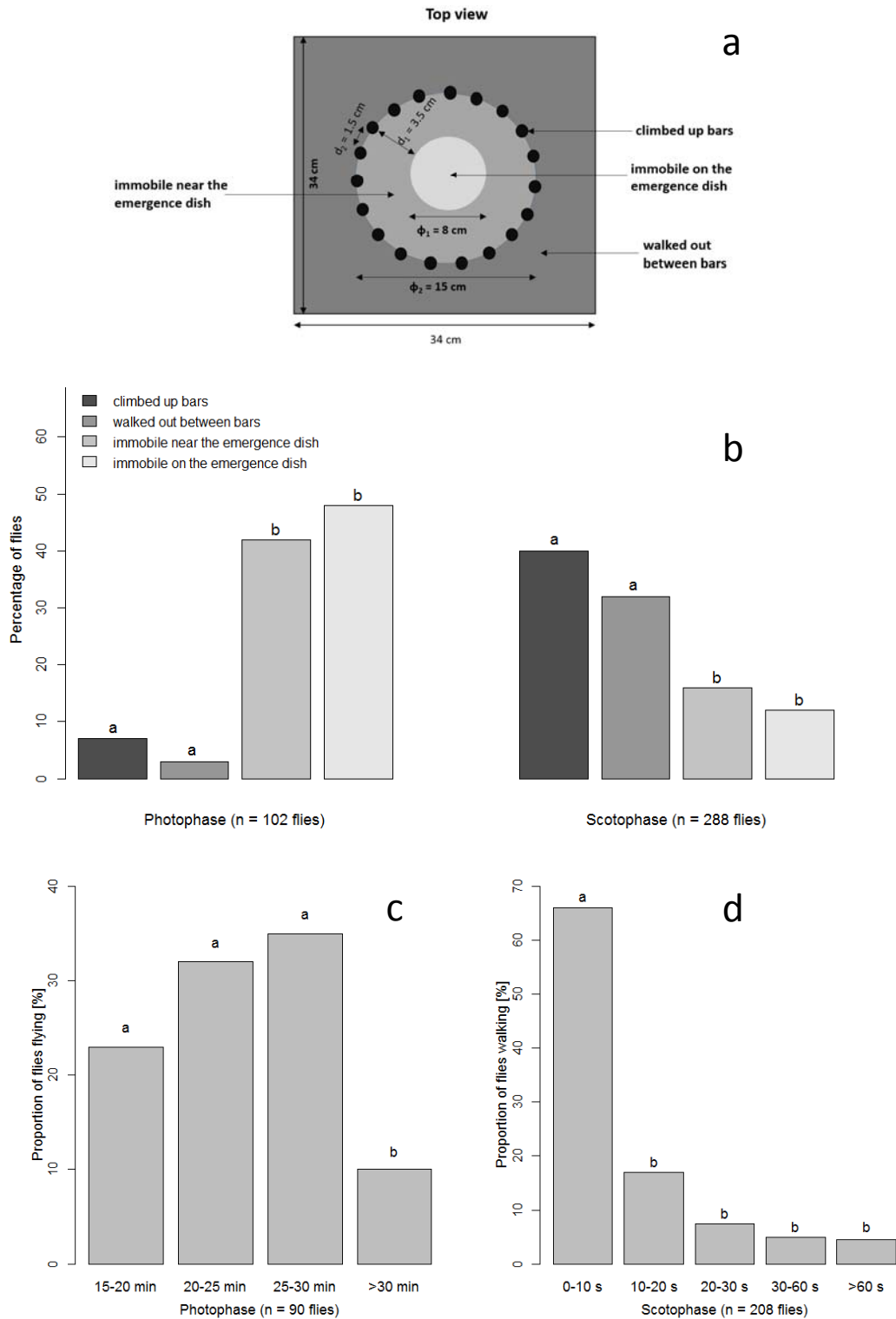

**Fig. 2.7.** Behaviour of *G. pallidipes* at emergence: **(a)** Assessment of negative geotaxis using 19 vertical and 3 T-bars (see also legend to Fig. 2.1) inserted 1.5 cm apart into a plywood base around the emergence dish in centre; **(b)** Negative geotaxis recorded on bars; **(c)** Time needed by immobile freshly-emerged flies to fly in the photophase and **(d)** Time needed by freshly-emerged flies to walk to bars during the scotophase. Bar plots with different letters on the same figure are statistically different at level of probability 0.05 following a GLM with binomial errors.

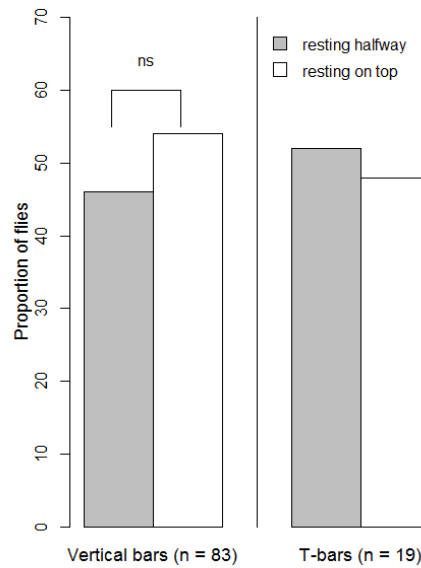

**Fig. 2.8.** Fly positions on bars in the scotophase (ns = not significant following a GLM with binomial errors,  $P > 0.05$ ).

*Did freshly-emerged G. pallidipes encounter vertical bars by coincidence in the scotophase?*

To answer such a question, spaces occupied by the vertical bars on the circular line (15 cm diameter, Fig. 2.7a) surrounding the emergence dish must be considered. The ratio of the spaces between the vertical bars to the spaces occupied by them on the circular line is 1.5 (3:2 in proportion). The observed proportion of freshly-emerged *G. pallidipes* that encountered the bars was different from the expectation 3:2 ( $\chi^2 = 4.5$ ,  $P = 0.03$ ; Table 2.1). Being that the probability for a freshly-emerged tsetse to encounter a vertical bar in the scotophase was 0.53, one can conclude that doing so was not a coincidence. All tsetse that encountered the bars climbed up.

**Table 2.1. Statistical comparison of the observed and expected proportions of freshly-emerged *G. pallidipes* (n = 208) that encountered vertical bars in the scotophase**

Climbing up bars	Observed (%)	Expected 3:2 (%)	$\chi^2$ value	<i>P</i> value
yes	55	40	4.5	0.03
no	45	60		

*Recruitment of G. pallidipes to horizontal bars over 24 hours*

7.8±0.7 *G. pallidipes* that emerged into the scotophase (0 day-old) were found resting on horizontally-suspended bars when lights were turned on (Fig. 2.9a). This number significantly decreased two hours later to 5.5±0.5 (GLM with Poisson errors,  $P<0.001$ ) and remained constant until the 11<sup>th</sup> hour into the photophase (Fig. 2.9a). Just at the end of the photophase significantly less flies (3.8±0.4) were counted on bars compared to the number at the 11<sup>th</sup> hour ( $P<0.05$ ). The same pattern was observed for 1-2 and 5-7 day-old tsetse with 6±0.6 and 5±0.4 flies, respectively, counted on bars when lights were turned on (Fig. 2.9b and c); then significantly decreased after 2 h to 4±0.3 and 1.6±0.2, for 1-2 and 5-7 day-old tsetse, respectively ( $P<0.05$ ).

A progressive recruitment to bars was observed for both 1-2 and 5-7 day-old *G. pallidipes* during the first 4 hours of the scotophase. Thereafter fly counts remained constant until onset of the photophase (Fig. 2.9b and c). Number of flies on bars at the end of scotophase was significantly higher than that at the end of the photophase for both teneral and fed *G. pallidipes* (GLM with Poisson errors,  $P<0.0001$ ). This provided evidence that flies flew to bars in the scotophase. Furthermore, teneral tsetse were more recruited to bars. As an example, an average numbers of 3.5±0.3 and 5.8±0.35 flies (1-2 day-old), respectively, hourly counted on bars during the photophase and scotophase compared to, respectively, 2.2±0.2 and 4.6±0.2 for 5-7 day-old flies (GLM with Poisson errors,  $P<0.01$ ).

To ensure that the IR light was not influencing the recruitment of flies in the scotophase a test was performed without the IR lamp. For this, 1-2 day-old tsetse were transferred into the test cage 1 h before the end of the photophase and the number of flies on bars was recorded at the end of the photophase and at the onset of the subsequent photophase. No difference was found between numbers of flies on bars at the end of the photophase and at the onset of the subsequent photophase with or without the IR source (Wilcoxon rank sum test,  $P>0.05$ , Fig. 2.10) confirming that recruitment to bars in the scotophase was not influenced by the IR source.

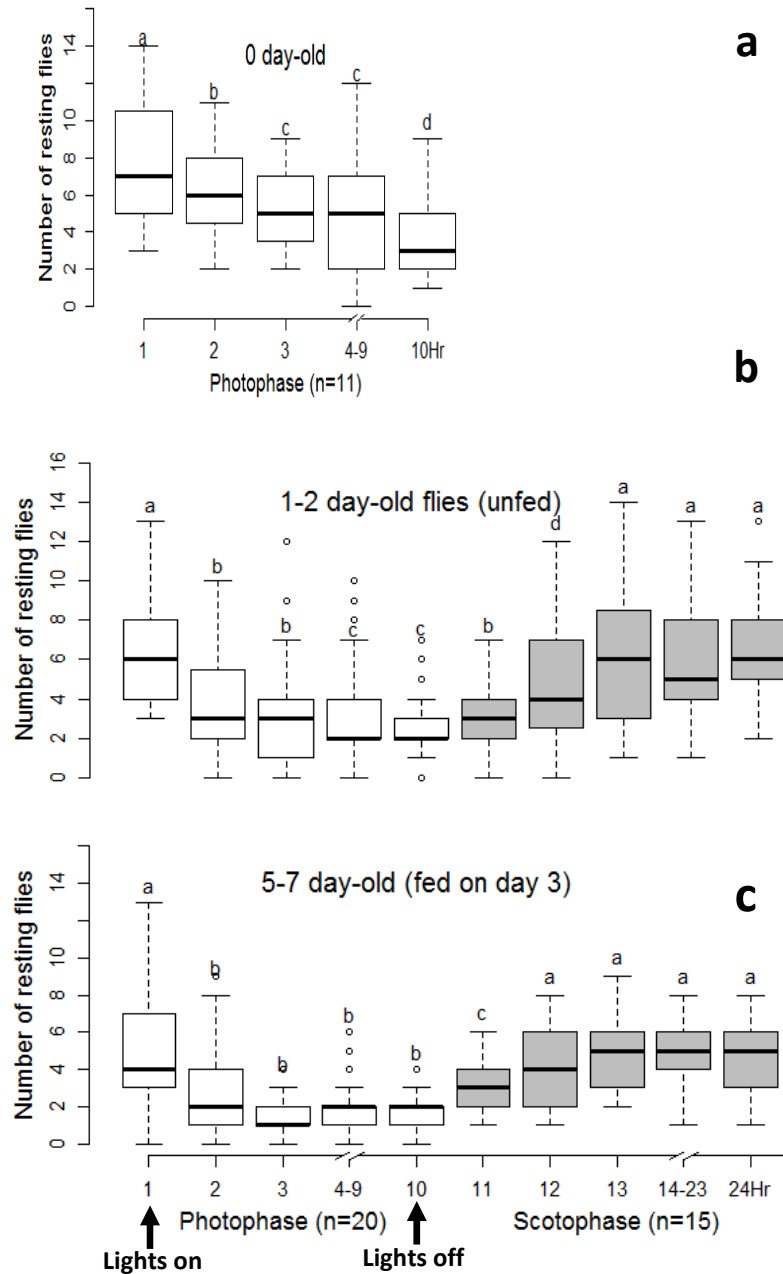

**Fig. 2.9.** Box plots of recruitment of *G. pallidipes* to triangular (apex pointing up) and round bars. Data for sex and bar types were pooled as there was no influence of bar choice by sex following a GLM with Poisson errors ( $P>0.5$ ); box plots represents the position of the median, minimum, maximum and the 25th - 75th quartiles of the numbers of resting flies. Each box plot with different letters on the same graph are statistically different (GLM with Gamma errors,  $P>0.5$ ); 30 flies were used per repetition ( $n=20$  and  $15$ , respectively, for observations in the photophase and scotophase) for both teneral (1-2 day-old) and fed tsetse. Especially for freshly-emerged tsetse (0 day-old) 25-35 were used ( $n=11$  repetitions). Box plots are presented for the 4<sup>th</sup>-11<sup>th</sup> hour in the photophase and 16<sup>th</sup>-23<sup>rd</sup> hour in the scotophase as fly numbers on bars remained constant during these time periods (GLM with Poisson errors,  $P>0.05$ ).

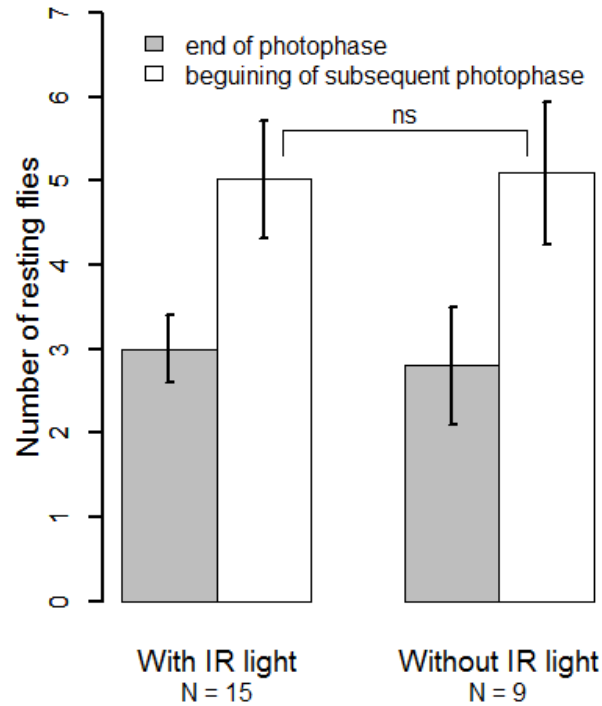

**Fig. 2.10.** Bar plots of recruitment (mean  $\pm$  SD) to horizontal round and triangular bars of teneral male and female *G. pallidipes* (1-2 day-old) at the end of the photophase and at the beginning of the subsequent photophase with and without an infrared (IR) source (see also Materials and Method and Fig. 2.1) used for video recording during the scotophase (N is the number of repetitions); ns = non significance difference following the Wilcoxon rank sum test ( $P > 0.05$ ).

#### *Resting positions of G. pallidipes on horizontal bars during the photophase and scotophase*

Resting positions of tsetse on bars during the scotophase was the opposite of that during the photophase (Fig. 2.11). As no statistical difference between teneral and fed flies (GLM with Poisson errors,  $P = 0.7$ ) nor between different lengths of starvation in teneral ( $P = 0.4$ ) and fed flies ( $P = 0.5$ ) was recorded, data for teneral and fed flies were pooled to provide a total of 143 and 166 resting flies, respectively, for photophase and scotophase observations. Flies preferred to hang on the underside of horizontal bars during the photophase with, respectively,  $83.6\% \pm 3.8$  ( $P < 0.0001$ ) and  $84\% \pm 2$  ( $P < 0.0001$ ) of flies on the undersides of the round and the triangular bars (Fig. 2.11). During the scotophase, flies preferred to sit on both the round ( $73\% \pm 3.5$ ,  $P < 0.001$ ) and triangular bars ( $74.5\% \pm 5$ ,  $P < 0.001$ ; Fig. 2.11). No influence of sex (GLM with Poisson errors,  $P = 0.8$ ) nor between bar types ( $P = 0.1$ ) was recorded.

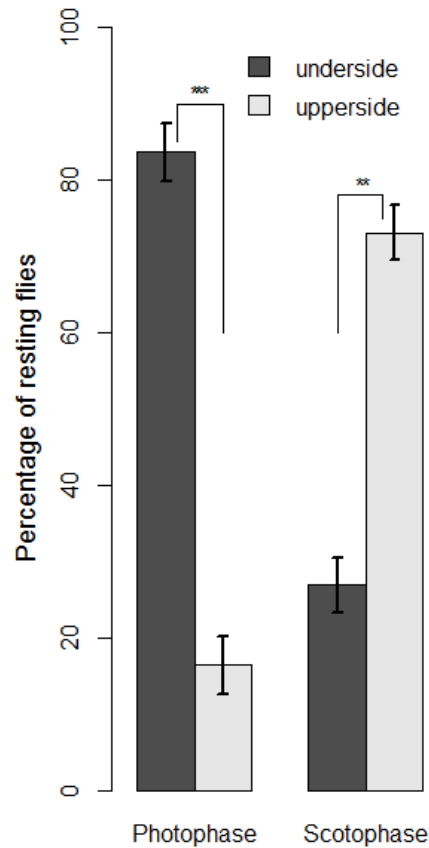

**Fig. 2.11.** Bar plots of resting positions (mean  $\pm$  SEM) on 24 cm long and horizontally-suspended round and triangular (apex up) bars by teneral (0-2 day-old) and fed male and female *G. pallidipes* (fed once and 3-5 days starved). Data for teneral and fed flies were pooled as they showed the same pattern (GLM with Poisson errors,  $P=0.85$ ). Asterisks indicate levels of probability (GLM with Poisson errors, \*\* $P<0.005$ , \*\*\* $P<0.0005$ ).

When fluorescent tubes were hidden in the scotophase no increase was observed between the recruitment of flies at the corresponding period (ANOVA,  $P>0.05$ ; Fig. 2.12) permitting to conclude that tsetse were exploiting the residual phosphorescence in the light tubes to gain access to the upper sides of bars during the early scotophase.

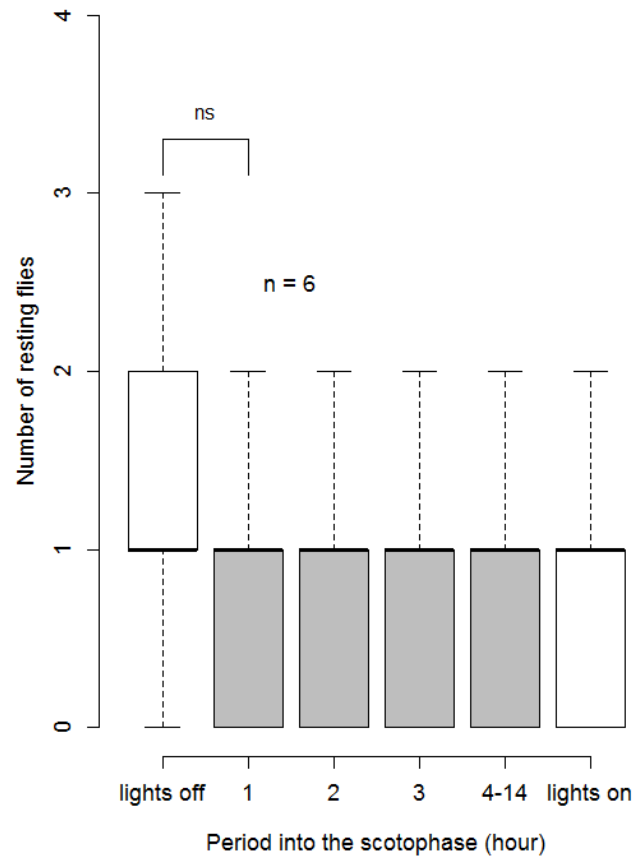

**Fig. 2.12.** Box plots (n= 6 repetitions) of recruitment to horizontal round and triangular bars of male and female *G. pallidipes* (1-2 day-old flies fed once) in the scotophase when the phosphorescence from the fluorescent tubes was hidden using black cardboard; each box plot represents the position of the median, minimum, maximum and the 25th - 75th quartiles boxes of the numbers of resting flies; ns = non significance difference following a GLM with Poisson errors ( $P>0.05$ ).

### *Residual phosphorescence in the scotophase*

The estimation of the residual light in the scotophase showed that, indeed, there was a phosphorescence from fluorescent tubes when lights were turned off. The illuminance fell rapidly from ca.  $1.2 \times 10^{-4}$  lux after 1 min to ca.  $2 \cdot 10^{-5}$  lux after 5 min, then decreased progressively to  $10^{-5}$  after 10 min before staying constant at ca.  $9 \cdot 10^{-6}$  lux after 1 h (Fig. 2.13).

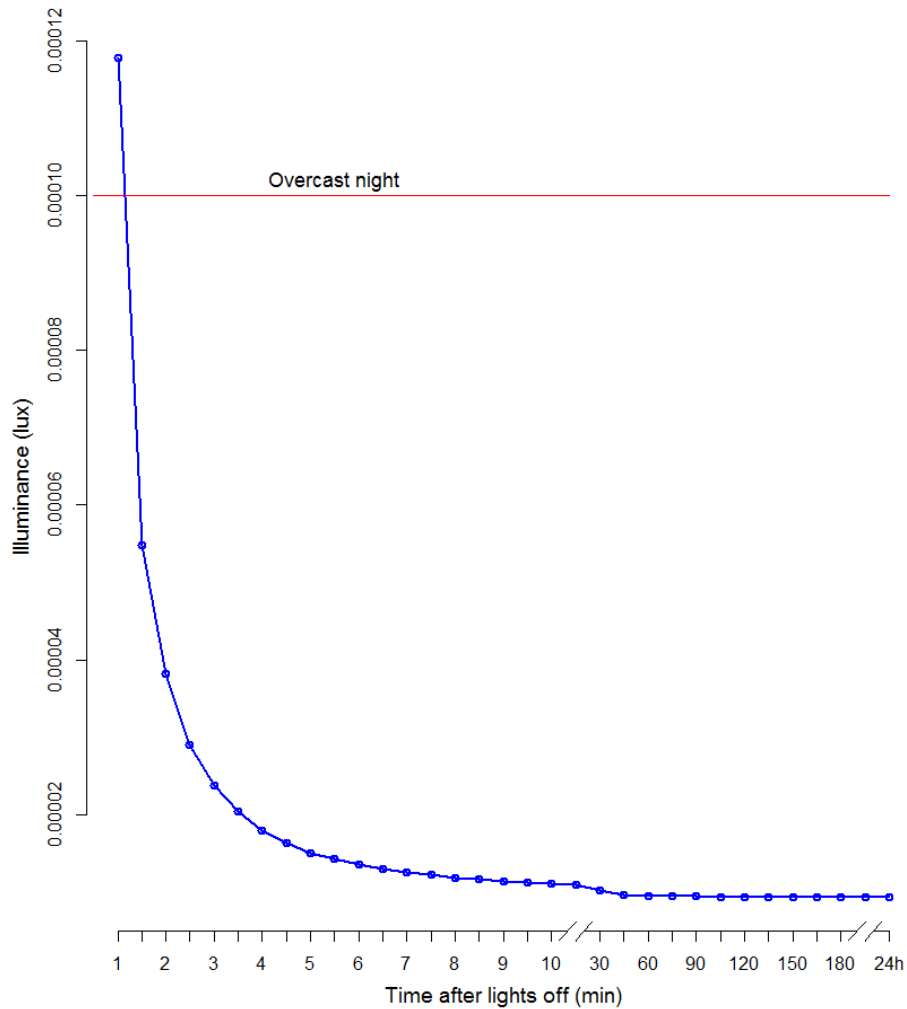
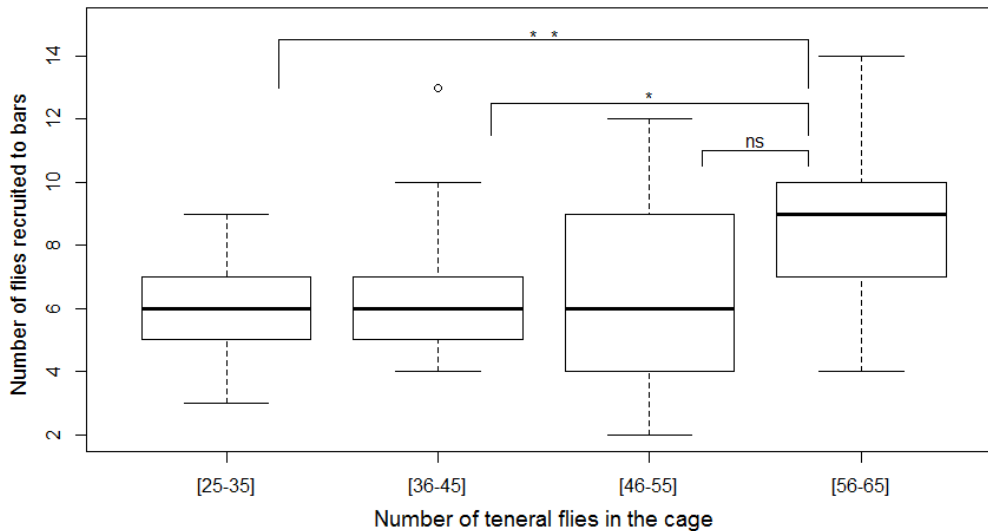

**Fig. 2.13.** Residual light emitted by fluorescent tubes in the environmental cabinet. The illuminance was calculated from the number of photons recorded using a photomultiplier calibrated with a lux meter (see Materials and Methods). The value ( $10^{-4}$  lux) of illuminance during an overcast night (Contor and Griffith, 1995) is shown on the figure for the matter of comparison.

#### *Effect of the number of *G. pallidipes* in the emergence cage on recruitment to bars*

Data of the resting behaviour recorded at 1 h into the photophase were analysed to determine some factors influencing the choice of horizontal bars by *G. pallidipes* in the cage. Recruitment to bars was similar when the number of flies was between 25 and 55 in the cage ( $n=10$ , GLM with Gamma errors,  $P>0.05$ ; Fig. 2.14). However, more flies were recruited when the number of flies exceeded 56 in the cage:  $7\pm 0.6$  flies were recruited to both round and triangular bars at more than 56 flies in the cage compared to  $6.6\pm 0.7$  with 46-55 flies in the

cage ( $N=10$ ,  $P<0.005$ ; Fig. 2.14). No difference was found in recruitment between bar types (round or triangular;  $P=0.2$ ).

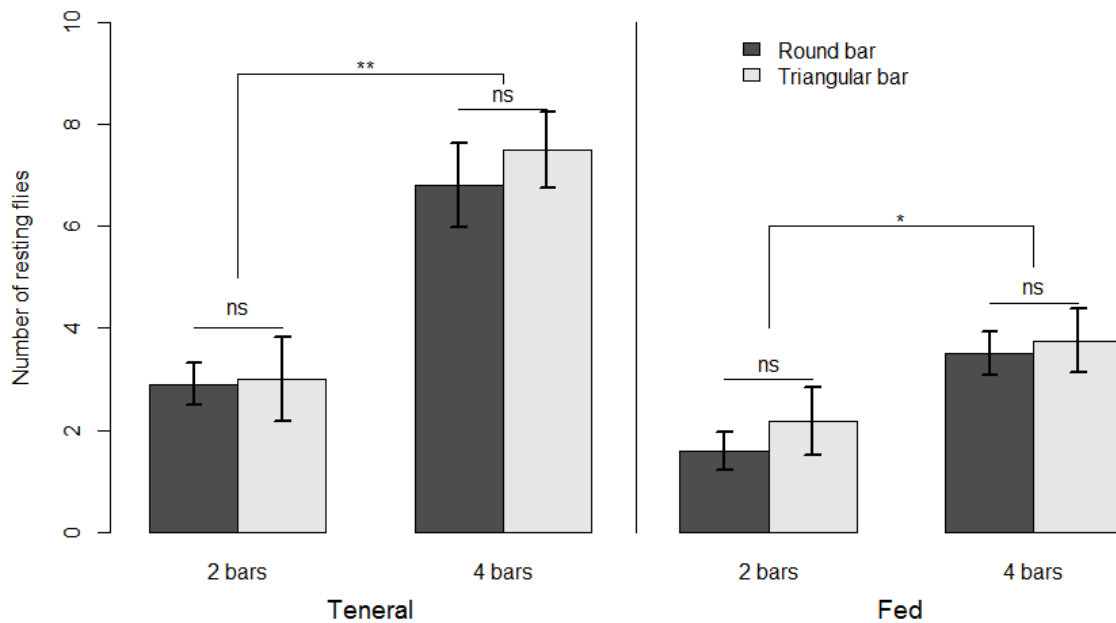

**Fig. 2.14.** Box plots of number of teneral (0 day-old) male and female *G. pallidipes* recruited to round and triangular (apex pointing up) 24 cm long bars at 1 h into the photophase as a function of the number of flies that emerged into the cage overnight. Each box plot represents the median, minimum, maximum and the 25<sup>th</sup> - 75<sup>th</sup> quartiles boxes. Asterisks indicate significant differences (GLM with Gamma errors, \* $P<0.05$ , \*\* $P<0.005$ , ns non-significant;  $n=10$  repetitions for any group).

#### *Effect of the number of bars on the recruitment of G. pallidipes to horizontal suspended bars*

25-30% and 10-15% of total number of flies in the cage were recruited to bars for teneral and fed *G. pallidipes*, respectively (Fig. 2.9). We hypothesized that this low recruitment may be due to the avoidance by the flies to rest near one another. To test this, the number of horizontal bars was doubled. Four rounds and triangular bars 24 cm long were presented alternatively at 15 cm from one another across the cage. The triangular bars had their apex pointing up. Doubling the number of bars increased the number of *G. pallidipes* recruited by a factor 2 for both teneral and fed flies with  $6.8\pm 0.7$  and  $7.5\pm 0.5$  teneral flies recruited, respectively, to round and triangular bars compared to  $2.95\pm 0.4$  and  $3\pm 0.7$  when only two bars were presented (GLM with Poisson errors,  $P<0.005$ ; Fig. 2.15). Increased recruitment of the same order with four bars was observed for fed flies with  $3.6\pm 0.3$  and  $3.8\pm 0.5$  flies versus  $1.7\pm 0.3$  and  $2.5\pm 0.5$  flies recruited, respectively, to round and triangular bars ( $P<0.05$ ; Fig.

2.15). No difference was found in recruitment between bar types for either teneral or fed flies ( $P=0.318$ ).



**Fig. 2.15.** Bar plots of recruitment (mean  $\pm$  SE,  $n = 12$  repetitions) of teneral (0 day-old) and fed (5-7 day-old) *G. pallidipes* (male and female) to any side of 24 cm long round and triangular (apex pointing up) bars 1 h into the photophase. Asterisks indicate significant differences (GLM with Poisson errors,  $*P<0.05$ ,  $**P<0.005$ , ns not significant). Data were pooled for males and females as there was no influence in the choice of bars by sex (GLM with Poisson errors,  $P=0.581$ ). Numbers of teneral flies were variable (25-35 flies per repetition) as adults emerged into the cage overnight, whereas 30 fed flies were used per repetition.

#### *Effect of the form of bars on the recruitment of G. pallidipes to horizontal suspended bars*

When a round bar and a triangular one with its apex pointing up, both 24 cm long, were presented no difference was observed in the choice of bars at 1 h into the photophase by either teneral or fed flies with  $2.95 \pm 0.4$  and  $3 \pm 0.8$  teneral flies, respectively, on the round and triangular bars (GLM with Poisson errors,  $P=0.47$ ) and  $1.6 \pm 0.4$  and  $2.2 \pm 0.7$  fed flies, respectively, on the round and triangular bars ( $P=0.09$ ; Fig. 2.16). Presenting the triangular bar with its apex pointing down did not influence the choice by teneral flies in contrast to fed flies where the triangular bar now recruited less flies ( $1.3 \pm 0.3$ ) than when its apex was pointing up ( $2.2 \pm 0.3$ ,  $P<0.005$ ).

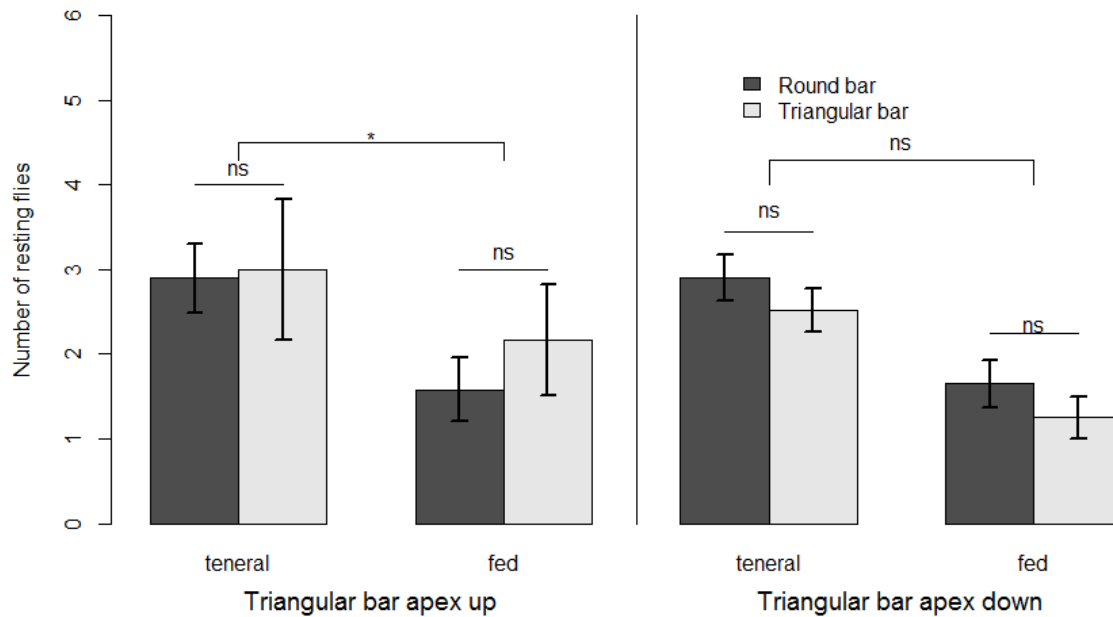

**Fig. 2.16.** Bar plots of resting preferences (mean  $\pm$  SE,  $n=20$  repetitions) by teneral (0 day-old) and fed (5-7 day-old) male and female *G. pallidipes* on any side of triangular and round bars 1 h into the photophase. The round bar was 24 cm long x 1 cm in diameter and the triangular one was 24 cm long x 1 cm high. 25-35 teneral and 30 fed flies were tested per experiment. Asterisks indicate significant differences (GLM with Poisson errors, \*  $P<0.05$ , \*\*  $P<0.005$ , ns not significant). Data were pooled for males and females as there was no influence in the choice of bars by sex (GLM with Poisson errors,  $P=0.46$ ).

#### *Effect of the size of bars on the recruitment of G. pallidipes to horizontal suspended bars*

When presented two cylindrical bars 1 cm in diameter but of different lengths (16 and 24 cm), teneral and fed *G. pallidipes* were found resting predominantly on the longer one at 1 h into the photophase with  $4.1\pm 0.3$  and  $2\pm 0.5$  teneral flies, respectively, on the longer and shorter bar (GLM with Poisson errors,  $P<0.005$ ) and  $3.3\pm 0.4$  and  $1.6\pm 0.3$  fed flies, respectively, on the longer and shorter bar ( $P<0.05$ ,  $n=20$ ; Fig. 2.17). Increasing the diameter of the shorter bar from 1 cm to 2 cm did not influence the preference for the longer bar by either teneral or fed flies (Fig. 2.17). No preference was observed for teneral flies when presented a choice between bars of the same length but of different diameters with  $3.5\pm 0.3$  flies on the 1 cm diameter bar and  $3.3\pm 0.4$  flies on the 2 cm diameter one ( $P>0.5$ ; Fig. 2.17). However, fed flies preferred the bar 1 cm in diameter over the one of the same length but 2 cm in diameter ( $2.4\pm 0.4$  versus  $1.3\pm 0.3$  resting flies, respectively,  $P<0.01$ ; Fig. 2.17).

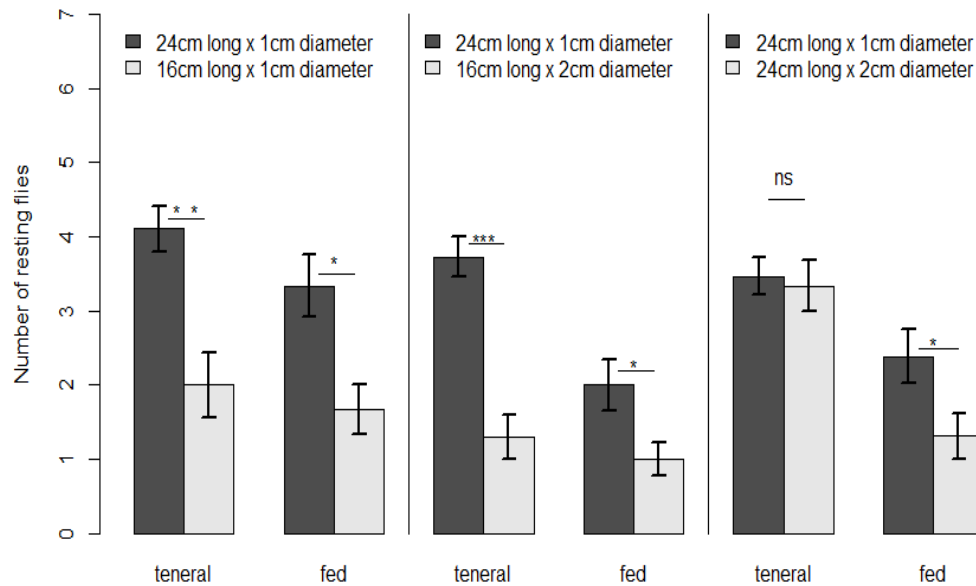
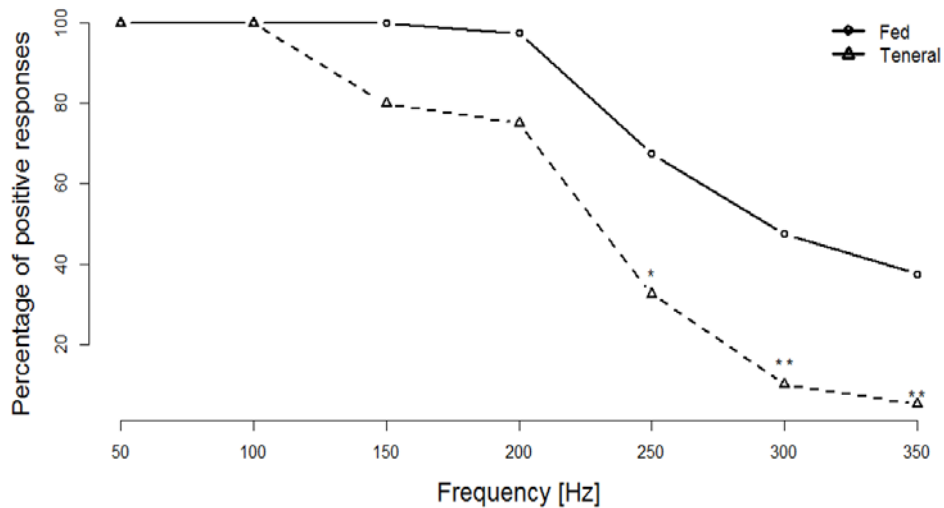

**Fig. 2.17.** Bar plots of resting preferences (mean  $\pm$  SE,  $n=20$  repetitions) by teneral and fed male and female *G. pallidipes* on any side of round bars 1 h into the photophase. Numbers of teneral flies were variable between repetitions (25-35 flies) as they emerged into the cage overnight; 30 fed flies were used. Asterisks indicate significant differences (GLM with Poisson errors, \*  $P<0.05$ , \*\*  $P<0.005$ , \*\*\*  $P<0.0005$ , ns not significant). Data were pooled for males and females as there was no influence in the choice of bars by sex (GLM with Poisson errors,  $P=0.62$ ).

The choice of the smaller diameter bar by fed *G. pallidipes*, as presented in Fig. 2.17, raised the hypothesis that the resting behaviour of tsetse is related to pertinent visual input from the environment. To attempt to understand it, a black square bar and a black rectangular parallelepiped were presented to 1 day-old *G. pallidipes* (males and females). The number of resting *G. pallidipes* counted on the square bar was  $3 \pm 0.6$ , three time higher than the  $1 \pm 0.7$  flies counted on the parallelepiped ( $n = 8$  repetitions, Wilcoxon rank sum test,  $P = 0.05$ ). 86% of resting flies was on the underside of the square bar, significantly different from the 50% of resting flies counted on the underside of the parallelepiped ( $F$ -test,  $F = 6$ ,  $P < 0.05$ ). These observations lend credence to the notion that *G. pallidipes* chooses the narrower resting substrates permitting a better view of the surroundings and that it is not shelter *per se* that matters.

### *G. pallidipes* visual resolution as a function of age

Unlike 5-7 day-old fed flies, 0 day-old teneral *G. pallidipes* did not distinguish between two bars of the same length but different in diameter (Fig. 2.17). We hypothesized that such choices were related to fly visual resolution, i.e. that the lack of discrimination between bars of different diameter in freshly emerged *G. pallidipes* could be due to the degree of eye maturation. The flicker fusion frequency (FFF) of the compound eye of teneral *G. pallidipes* as determined by their optomotor reactions to moving black and white vertical stripes showed that the percentage of flies that responded positively, i.e. that moved in the direction of the rotating stripes, decreased from 100% at 100 Hz to 80% at 150 Hz and thereafter dropped off rapidly to 8% of flies responding positively at 300 Hz (Fig. 2.18). The FFF, i.e. the frequency where 50% of positive responses occurred in 1 day-old teneral tsetse was found between 200 and 250 Hz whereas this was at 300 Hz for 7 day-old flies fed once. In fed *G. pallidipes* all flies still responded positively to the moving stripes at 200 Hz and the number responding decreased progressively to 300 Hz where about 50% of flies still responded (Fig. 2.18). A significant difference between the proportions of responding teneral and fed flies was recorded from 250 Hz (mixed effect model with Poisson errors,  $P=0.03$ ). No effect of sex was recorded for either teneral or fed flies ( $P=0.39$ ).



**Fig. 2.18.** Optomotor reaction curves of 1 day-old teneral and 7 day-old fed and starved (for 4 days) male and female *G. pallidipes* to moving mat black and white vertical stripes. Asterisks indicates significant differences between responses teneral and fed flies at a given frequency (mixed effect model with Poisson errors, \* $P < 0.05$ , \*\* $P < 0.005$ ).

The higher visual resolution of fed flies was confirmed by ERG measurements. No statistical difference was recorded between male and female teneral or fed *G. pallidipes* (GLM with Poisson errors,  $P = 0.13$ ). The FFF of freshly emerged tsetse (less than 12 hour-old) at a mean of  $125.5 \pm 15$  Hz was significantly lower than the FFF of  $175 \pm 22$  Hz recorded for 7 day-old tsetse fed once at day 3 ( $P < 0.005$ ; Fig. 2.19). FFF was not related to feeding since the FFF of 3 day-old teneral *G. pallidipes* (male and female) was statistically no different to that of 12 day-old flies (males or females) fed twice and starved for 5 days ( $P = 0.55$ ,  $n = 14$  flies). A significant higher FFF was already recorded for 1 day-old flies compared to 0 day-old ones ( $P < 0.05$ ; Fig. 2.19). Moreover, the general pattern of the evolution of the FFF over one month in *G. pallidipes* showed a rapid increase in FFF from 125 Hz in 0 day-old flies to 185 Hz in 3 day-old ones, a stabilization over ca. 13 days and thereafter a significant subsequent increase to 220 and 265 Hz, respectively, at day 17 and 27 (Fig. 2.19).

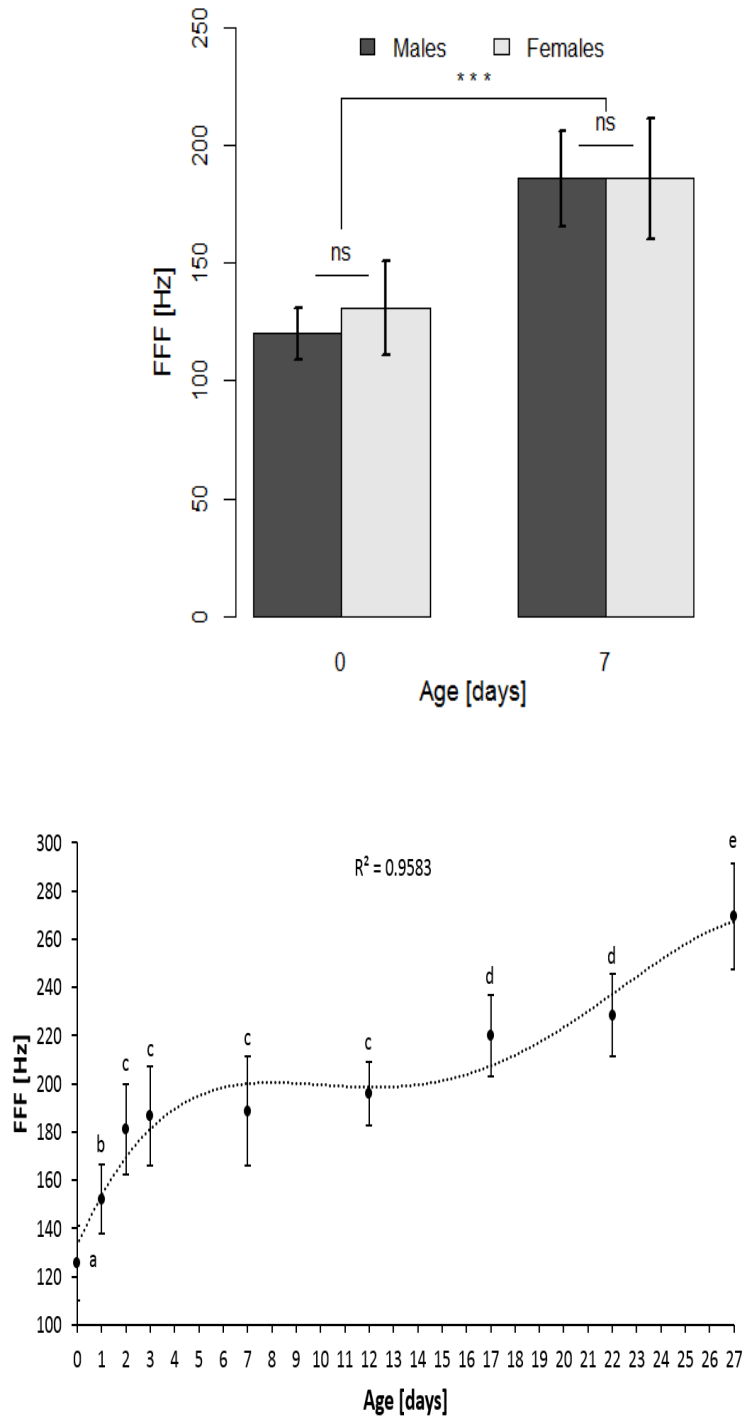

**Fig. 2.19.** Mean flicker fusion frequency (FFF) at the fronto-lateral part of the compound eye of teneral and fed *G. pallidipes* (males and females) as measured by ERG. Data are presented as mean FFF  $\pm$  SD (n=7 flies in each case). **Top** freshly-emerged and fed flies used in behavioural experiments with horizontal bars, \*\*\* $P$ <0.0005; **bottom** FFF (pooled data for males and females) as a function of age. FFF Values with different letters are statistically different at level of probability 0.05 (GLM with Poisson errors).

## 2.4. Discussion and conclusions

We investigated here the resting behaviour of *G. pallidipes* from their emergence to their mature state under light and dark conditions. We observed a remarkable predilection for negative geotaxis by *G. pallidipes* immediately after emergence in the scotophase whereas in the photophase, they stay longer immobile until their complete metamorphosis before flying. Freshly-emerged and mature *G. pallidipes* clearly were able to fly to resting sites in the scotophase. The predilection for tsetse to use bars as resting sites was stronger in the scotophase and resting positions on bars are different following photophase and scotophase. The number of flies or bars in the test cage influenced the choice of bars as resting sites by *G. pallidipes* and older flies were able to discriminate a preferred horizontal longer substrate for resting under light conditions. Furthermore, older *G. pallidipes* discriminate between bars of different diameter and this is probably related to their higher visual acuity as shown by ERG and optomotor experiments. These observations are discussed below in the context of survival strategies in tsetse.

### *Negative geotaxis in freshly-emerged G. pallidipes*

We have recorded emergence by *G. pallidipes* throughout the light cycle in the laboratory (emergence ratio photophase: scotophase of 0.94). Whereas the peak of emergence by *G. morsitans* is in the mid-afternoon (Bursell, 1958) emergence may occur at night depending on the maturation of pupae in the field. Some 90% of freshly-emerged *G. pallidipes* stayed immobile for more than 15 min on or near the emergence dish during the photophase. Zdárek and Denlinger (1992) observed in the laboratory under light conditions that freshly-emerged *G. brevipalpis* and *G. austeni* generally remained immobile at the emergence site for at least 15 min presumably to complete metamorphosis, a behaviour also noted by Southon (1958) in the field for *G. swynnertoni*. This immobility in freshly-emerged tsetse can be considered as an adaptation in the presence of the light to avoid attracting attention of predators such as beetles and lizards (Southon, 1958, Southon, 1956). This strategy is rendered possible since tsetse colours (brown or dark brown) match to their emergence sites that are moist soil, rot holes, undersides of fallen logs (Harley, 1954). By contrast, during the scotophase more than 60% of freshly-emerged tsetse moved off within 30 s of hatching to climb vertical bars or walked further away from the emergence dish to

climb up the walls of the cage, behaviours that can be interpreted as an adaptation to seek a refuge off the ground under cover of darkness.

#### *Recruitment of G. pallidipes to horizontal bars*

Newly-emerged tsetse flew onto the suspended horizontal bars from the floor, the walls or the roof of the cage during the night of their emergence. Recruitment of 1-2 day-old teneral tsetse to horizontal bars was also recorded and was higher than that of 5-7 day-old fed flies. A progressive increase in the number of teneral and fed flies recruited to bars was observed during the first three hours of the scotophase and was 2-3 fold superior to the number of flies on bars in the corresponding period of the photophase for both 1-2 day-old teneral and 5-7 day-old fed flies. The only light source available during the scotophase in the environmental cabinet where experiments were conducted was from the residual phosphorescence of the fluorescent tubes after light off and from the IR lamp. Tsetse are not sensitive to the IR light (Green and Cosens, 1983). The number of tsetse on horizontal bars at the onset of the photophase was the same whether the IR lamp was turned on or not. Furthermore, hiding the fluorescent tubes with black cardboard annulled the recruitment of *G. pallidipes* to bars during the scotophase. Apparently *G. pallidipes* can identify objects to fly to in near darkness ( $<10^{-4}$  lux) allowing freshly emerged-tsetse to fly to suitable perches off the ground before dawn. Evidently the mechanism that *G. pallidipes* uses for such precise orientation in near darkness remains to be elucidated. However, activity of *G. pallidipes* on moonlit nights had been suspected based on the fact that flies were less active on following days (Vanderplank, 1941) and it has even been suggested that both sexes of *G. pallidipes* may be active throughout moonlit nights (Chorley and Hopkins, 1942). Night activity by *G. austeni* and *G. brevipalpis* has been reported through their ability to attack humans at night (Moggrige, 1948, Kappmeier, 2000a).

#### *Resting positions of flies on horizontal bars over 24 hours*

Both teneral and fed flies hung on the undersides of horizontal bars during the photophase whereas most tsetse that chose horizontal bars as resting sites sat on the upper surfaces during the scotophase. The undersides of horizontal branches have been documented as the most preferred sites for resting by tsetse during daytime as for example for *G. pallidipes* (Pilson and Leggate, 1962), for *G. f. fuscipes* (Okoth and Kapaata, 1987), and

for *G. f. congolensis* and *G. longipalpis* (Omoogun, 1985). It is assumed that the resting behaviour of tsetse is related to their hunger state since recently engorged tsetse chose vertical resting sites like tree trunks with their head up to facilitate digestion whereas hungry flies rest on the undersides of branches (Nash, 1952). Undersides of branches evidently provide shadow and cooler places for tsetse to rest during the day (Vale, 1971, Hargrove, 1999, Hargrove and Packer, 1993, Torr and Hargrove, 1999) serving to reduce metabolic rate and lower feeding requirements (Bursell and Taylor, 1980). On the other hand, several works have reported on the propensity of tsetse to rest on the upper sides of vegetation (especially leaves) at night under natural conditions (McDonald, 1960, Spielberger and Barwinek, 1978, Chorley and Hopkins, 1942, Scholz et al., 1976, Jewell, 1958). Such resting sites are illuminated at night by moonlight or starlight and our observations clearly suggest that *G. pallidipes* can exploit lower light level to identify pertinent visual input from the environment. Resting on the upper surface of an object in the dark appears to be an innate behaviour in *G. pallidipes* as both freshly-emerged and fed tsetse positioned themselves on the upper sides of bars during the scotophase. This is most probably an adaptation for the detection of moving objects against the brighter background provided by the night sky. The predilection of tsetse to rest on the upper sides of leaves at night was interpreted by Minter (1971) as an adaptation to prevent predation since leaves easily transmit vibrations caused by any approaching predators such as beetles, spiders, lizards etc.

#### *Effect of the bar number and the fly density on recruitment of G. pallidipes*

When the number of horizontal suspended bars was doubled a proportional increase in numbers of recruited teneral and fed tsetse was recorded during the morning peak of their activity. This suggests that increasing the number of resting sites available on horizontal bars increases the probability of recruiting tsetse. The presence of tsetse on bars may limit recruitment of others since, respectively, only 25-30% and 10-15% of teneral and fed tsetse in test cages were recruited to bars. Furthermore, recruitment to a constant number of bars increased by the factor 1.5 when the number of tsetse in the cage increased from 30 to more than 55, suggesting that recruitment of flies to bars is density dependent. These findings appear to suggest certain dynamics in the use of suitable space at suitable resting sites by tsetse as a function of fly density that may merit further investigation.

*Effect of the size of bars on the recruitment of G. pallidipes*

Flies showed a preference for a longer bar and doubling the diameter of a shorter one did not change this preference either for teneral or for fed flies. When two bars of the same length but of different diameters were presented, fed tsetse clearly showed a preference for the bar of smaller diameter whereas teneral flies did not discriminate between the bars. Increasing the width of the resting substrate to 6 cm to provide more shadow was less attractive to teneral as a resting site when presented simultaneously with a square 1 cm width bar. Small branches and twigs permit a better visual control of the surroundings for tsetse allowing them to detect predators and simultaneously provide a vantage point to localise moving hosts (Nash, 1952, Okiwelu, 1982, Okiwelu, 1983, Okiwelu, 1977). Such resting sites are susceptible to transmit vibrations caused by an approaching predators (Minter, 1971) and could explain the choice of smaller diameter bar by fed tsetse. However, this choice for a smaller diameter bar could also be influenced by the perimeter-surface area ratio (PSR, Annex 1) of the object: the greater the PSR the greater the landing response of tsetse per unit surface area. The PSR of the smaller diameter bar at 208.33 was double that of the bigger diameter one at 108.33. No difference was observed in the choice of the round and the triangular bars whose PSR varied between 181.6 and 208.33 depending on the position of the fly approaching from below, above or towards the bar, supporting the notion that the PSR influences the recruitment of tsetse to visual objects. Horizontal branches constitute preferred resting sites in the field as reported for example for *G. f. fuscipes* (Okoth and Kapaata, 1987), *G. pallidipes* (Pilson and Leggate, 1962) and *G. f. congolensis* (Omoogun, 1985). Preference for branches or twigs following the diameter by mature or teneral tsetse is not investigated. On the basis of our findings, mature tsetse may be most frequently found on smaller diameter horizontal branches or twigs than newly-emerged ones in the field. However, we did not investigate the effect of temperature on the choice by *G. pallidipes* of objects of different width, i.e. different capacity to provide shadow. An increase in temperature may lead flies to choose for example 6 cm width resting substrate as resting sites. Preference for objects with a long horizontal component probably explains why both *G. pallidipes* and *G. m. morsitans* land more on horizontal targets versus vertical ones in the field (Vale, 1974b, Torr, 1989, Vale, 1993a, Tirados et al., 2011). More recently it was reported that blue-black 0.5 x 0.75 m horizontal oblong caught more *G. f. fuscipes* and *G. tachinoides* by unit surface area in the field than

bigger targets (Oloo et al., 2014) since reducing the size results in an increase in PSR. In the laboratory a triangular black target was found more attractive to *G. m. morsitans* than a circular or square one of the same surface area but with a smaller perimeter (Doku and Brady, 1989). Teneral *G. pallidipes* did not show a preference between bars of different diameters in our experiments, suggesting a difference in visual resolution between teneral and fed flies as discussed below.

#### *G. pallidipes* visual resolution

The FFF of 1 day-old *G. pallidipes* was estimated to be ca. 250 Hz, 1.3 time lower than that of 7 day-old flies estimated at 300 Hz by optomotor responses. Using ERG the FFF was found to be 125 Hz (range 110-140 Hz) for 1 day-old teneral, 1.5 time lower than the 190 Hz (range 165-215 Hz) recorded for 7 day-old fed *G. pallidipes*. These FFF values indicate a clear difference between teneral and older tsetse tested in our experiments. FFF values for 7 day-old *G. pallidipes* recorded here by ERG fall within the range of 150-233 Hz recorded for 90 min dark-adapted male and female wild-caught *G. m. morsitans* (age not specified) determined by Miall (1978) and are in agreement to that recorded for bees at 220 Hz by Autrum and Stoecker (1950) using the optomotor response. High FFF values recorded in tsetse places them in the “fast-eye” insect group such as honeybees, dragonflies and blowflies with FFF values ranging from 180 to over 300 Hz (Autrum and Gallwitz, 1951, Autrum, 1950, Autrum and Stoecker, 1950). Even though FFF estimations can be influenced by the techniques used as in this study, it is obvious that FFF of teneral tsetse is lower than that of fed flies. This lends credence to the notion that tsetse eye maturation could influence the choice of objects used as resting sites. The evolution of the FFF values of laboratory reared *G. pallidipes* over one month recorded here showed a rapid increase during the teneral life of the fly (day 0 - day 3) where FFF values increased from 125 to 185 Hz followed by a stabilization period lasting 7 - 8 days and finally a subsequent increase from 192 Hz (day 12) to 270 Hz (day 27). This FFF evolution obviously follows the pattern of the maturation of *G. pallidipes* compound eyes as a function of age. Such a pattern has been reported in the nocturnal dung beetle *Onitis aygulus* where maturation of the crystalline cones and cornea of the compound eyes proceeded quickly during the first 3 days, and then more slowly, with full maturation attained by the end of the second week (Warrant et al., 1990).

### *Understanding the fundamental survival strategies in tsetse*

Tsetse as K-strategists develop more strategies to deal with climatic and environmental factors to maintain its species survival. The big challenge in the tsetse life is to live across the hot and dry season where mean day temperatures are above 32°C affecting flies of different sexes, species, nutritional states and pregnancy stage at different level (Vale, 1971, Hargrove, 1999, Hargrove and Packer, 1993, Torr and Hargrove, 1999). It has been estimated that the oxygen consumption by tsetse increases linearly from 15 to 35°C (Taylor, 1977) and that at 35.6°C (76% RH) 50% of wild caught *G. pallidipes* population would survive for 3 h (Terblanche et al., 2008). Hot seasons cause a shorter pupal period in female tsetse, a production of smaller pupae sizes due to fewer blood meals and, consequently, an increase of the proportion of smaller individuals in tsetse populations (Bursell, 1960, Phelps and Clarke, 1974) which have to feed more frequently. In addition, increasing in feeding frequency results in an increase of risks from predation and from the host grooming response (Randolph et al., 1992). All these factors explain the crash of tsetse populations that can decline by 90% during hot and dry seasons (Hargrove, 1999, Torr and Hargrove, 1999). During such periods it is crucial for tsetse to seek shelter in refuges that provide cooler, humid and shady microhabitats that decrease their metabolic cost by limiting the respiration rate (Vale, 1971, Torr and Hargrove, 1999). The predilection for cooler and humid places when temperatures are high had been reported for insects in general (Bar-Zeev, 1960, Kessler and Guerin, 2008, Willmer, 1994, Crooks and Randolph, 2006) and tsetse are equipped with hygrosensors to detect humidity (Chappuis et al., 2013).

The other tsetse challenge is to avoid predation. Beetles and ants have been recorded as predators of adult tsetse and *G. swynnertoni* constituted 15% of prey taken by asilid flies (Southon, 1958). During the daytime tsetse prefer to rest with their body axis parallel to horizontal branches and twigs where they choose the undersides as observed in the present work. This behaviour is considered to be a strategy for tsetse to have a better visual control of their surroundings (Nash, 1952, Okiwelu, 1982, Okiwelu, 1983, Okiwelu, 1977) presumably to prevent predation and to locate hosts for feeding. On the other hand, since black tsetse (morsitans group) choose black and grey barks, while brown ones (palpalis group) chose brown barks, hiding on the undersides of lateral and horizontal branches usually black or brown where shade is more pronounced is a part of strategies by tsetse to avoid predators

Swynnerton (1936). However, resting behaviour of tsetse is related to their hunger stages as recently engorged tsetse choose vertical resting sites like tree trunks with their head up to facilitate digestion whereas hungry flies rest on the undersides of horizontal branches or twigs (Leak, 1999). Beside these diurnal adaptations tsetse have also to survive at night. Our results support observations that tsetse can be active at night (Moggrige, 1948, Kappmeier, 2000a, Chorley and Hopkins, 1942) and this certainly because of their adaptation to the near dark vision. This is particularly important for freshly-emerged tsetse to find perches after emergence and for females at the end of pregnancy stage and which have to find a larviposition site when needed at night.

To summarize, despite interest showed by researchers for studying tsetse behaviour and ecology, little attention has been paid to the genesis of fundamental survival strategies in tsetse. We have recorded here how the recognition and exploitation of physical objects as resting sites by *G. pallidipes* under light and dark conditions is an innate behaviour critical for the tsetse survival. These adaptations may serve (1) as a means of seeking shelter from extreme climatic conditions, (2) as vantage points to locate hosts for feeding and (3) to reduce predation, three main factors for survival in tsetse. As treated in the following chapter, horizontal resting sites may be envisaged as a strong landing stimulus if associated to conventional visual baits for tsetse control.



## **Annex**

**Annex: Perceived perimeter-surface area ratios (PSR) of bars used in resting site experiments**

	<b>bar 1</b>		<b>bar 2</b>		<b>bar 3</b>		<b>bar 4</b>	
	length 1	diameter 1	length2	diameter 2	length 3	diameter 3	length 4	diameter 4
<b>dimension (m)</b>	0.24	0.01	0.24	0.02	0.16	0.01	0.16	0.02
<b>Surface area* (m<sup>2</sup>)</b>	0.0024		0.0048		0.0016		0.0032	
<b>perimeter (m)</b>	0.5		0.52		0.34		0.36	
<b>PSR</b>	<b>208.33</b>		<b>108.33</b>		<b>212.50</b>		<b>112.50</b>	

(\*) Bars are considered as rectangular surfaces; surface area = length x diameter.

### **3. Improvement of landing response of *Morsitans tsetse* on a small blue target in the wind tunnel**

## Abstract

Improvement of tools for tsetse population control has been focused on reducing the size of visual targets to smaller targets that were found efficient only for controlling *Palpalis* tsetse. Here, I made an attempt to improve landing response by the Morsitans tsetse *G. pallidipes* through laboratory studies. Landing and resting sites by *G. pallidipes* on 225 cm<sup>2</sup> blue visual targets (triangle, disk, square and diamond) were assessed in a circular free-flight arena. *G. pallidipes* landed and rested mostly on the bottom and centre of targets presented on the wall of the arena. Tests were then made in the wind tunnel in the presence of 25 cm x 25 cm blue, black and blue-black two-dimensional (2D) targets in square, diamond and disk shapes, and in the presence of a blue and black 16 cm diameter sphere as three-dimensional (3D) objects. Characteristics (straightness, velocity and altitude) of *G. pallidipes* upwind flight to visual targets were similar in the wind tunnel. Flies investigated visual targets by flying around their bottom. Landing by *G. pallidipes* was significantly low (<10%) on an all-black 2D target (square and disk) compared to 25 – 35% recorded on blue and blue-black 2D visual targets. Significantly high landing responses were recorded in the presence of 3D objects with, respectively, 73% and 49% for the blue and black sphere compared to 2D objects. Adding a black 3D round or triangular bar at the bottom of the blue square improve first landings and subsequent landings (landings at least two times by the same fly) by *G. pallidipes* on the targets by a factor 2 compared to that recorded on the all-blue. However, subsequent landing distributions by *G. pallidipes* on blue targets were different from those of the first landings in that when a black bar (round or triangular) was present, subsequent landings were biased on the bottom and on the bar whereas for the all-blue, such landings were high in the centre. 25 cm x 25 cm blue square incorporating at the base a black 3D bar similar to horizontal resting sites of tsetse shows promise as a cost-effective device to use as visual baits impregnated with insecticide for controlling tsetse.

**Keywords:** resting sites of tsetse, wind tunnel, 2D and 3D visual targets, landing response, tsetse control.

### 3.1. Introduction

Recent field studies on visual responses of tsetse to different designs of targets have shown, especially for Palpalis tsetse that reducing visual targets of standard size (1 m x 1 m) to smaller targets (0.25 m x 0.25 m), conventionally called tiny targets, catches equivalent or even more flies by unit surface area than standard ones. This is the case for black tiny targets used for *G. tachinoides* and *G. p. gambiensis* in Burkina faso, *G. f. quanzensis* in the Democratic Republic of Congo, *G. f. martini* in Tanzania and *G. f. fuscipes* in Kenya (Esterhuizen et al., 2011b). Black tiny targets flanked by a panel of black fine netting of the same size (to intercept tsetse circling around targets) caught more *G. f. fuscipes* per unit surface area compared to targets of standard size in Kenya (Lindh et al., 2009). The same devices made of blue cloth and impregnated with deltamethrin were recently used to control *G. f. fuscipes* in Uganda (Tirados et al., 2015). “Horizontal” devices 0.75 m wide x 0.5 m high consisting of blue cloth placed between two panels of fine black netting (1:2:1 in proportion) increased the catch of *G. p. gambiensis* and *G. tachinoides* in Burkina Faso (Rayaisse et al., 2011). Reducing the size of a visual target results in an increase in the perimeter length of the target relative to its surface area (perimeter/surface area ratio) and may explain the efficiency of tiny targets against Palpalis tsetse. Attempts to reduce the size of visual targets for Morsitans tsetse were also made. Blue and blue-black-blue oblong 0.5 m<sup>2</sup> targets (1 m wide x 0.5 m high) covered by adhesive film captured equivalent numbers of *G. pallidipes* and *G. swynnetorni* per unit surface area compared with standard targets (Mramba et al., 2013). Nevertheless, black tiny targets were tested for *G. pallidipes* and *G. m. morsitans* in Zimbabwe and were found inefficient in comparison to visual targets of standard size (Torr et al., 2011). Unsatisfactory results were already reported with 2D tiny targets for Morsitans tsetse, even for those flanked by nets (Hargrove, 1980, Vale, 1993b). Two possible conclusions can be drawn from these observations: the perimeter/surface area ratio theory is not working for Morsitans tsetse at the level of the tiny target size or tiny targets with the right colour or combination of colours has not yet been tested for such tsetse.

Resting site preferences of tsetse retained our attention in the context of improvement of their landing responses on visual targets. Such resting sites have been extensively studied in the field and are almost similar for all tsetse species in that the undersides of horizontal branches are their common preferred diurnal resting sites (Okoth and Kapaata, 1987,

Abdurrahim, 1971, Omoogun, 1985, Pilson and Leggate, 1962). To improve landings by *Morsitans tsetse* on tiny visual targets, we hypothesized that equipping such targets with a landing stimulus based on resting site preferences may make them more efficient as devices capable to induce landings. This hypothesis was based on (1) the propensity of *Morsitans tsetse* to be attracted by horizontal targets (Vale, 1993b), (2) the sensitivity of tsetse to contrast between blue and black colours on objects (Green, 1989) and (3) the efficiency of three dimensional (3D) objects to induce landings by tsetse (Vale, 1969, Vale, 1974a, Challier and Laveissière, 1973, Rayaisse et al., 2012). Tsetse resting sites with horizontal aspect provide opportunity to investigate this hypothesis. For this, various blue, black and blue-black tiny visual targets of different shapes were tested in an arena and in a wind tunnel permitting the recording of flight behaviours and landing responses by *G. pallidipes*. We have made an attempt to improve landing responses by *G. pallidipes* on a blue tiny target by adding a 3D horizontal resting site to it.

### 3.2. Materials and methods

#### *Insects*

*G. pallidipes* pupae were obtained from the International Atomic Energy Agency (IAEA, Vienna) and adults were maintained at environmental conditions similar to those described in chapter 2. Females and males were separated at emergence (day 0) to prevent mating. Teneral flies were tested on day 1 in the arena and on day 2 or 3 in the wind tunnel. Flies were fed on day 3 with heparinised (1000 UI/ml) bovine blood through a silicon membrane and were tested on day 8, i.e. starved for 5 days, in the arena and in the wind tunnel.

#### *Experiments in the free-flight arena*

A circular free-flight insect arena (Fig. 3.1), built by Dr Bernáth Balázs, Institute of Biology, University of Neuchâtel, and was installed in an environmental cabinet at 25°C and 65% RH. The arena constructed of three metal plates that formed a cylinder with a diameter of 115 cm and height of 56 cm that stood on the floor of the environmental cabinet. The upper rim of the arena cylinder was reinforced by a 16 mm thick plywood ring with an inner diameter of 111 cm and outer diameter of 125 cm. The plywood ring supported stretched black polyester netting (Swisstulle 182/21) that closed the top of the arena. The floor and the inner surface of the cylinder were covered by matt white bench-top paper (Benchguard BG50E, Bibby Sterling LTD, Staffordshire, England). A projector equipped with halogen lamp (HLX 64657, 250 W, XENOPHOT®, OSRAM GmbH, Augsburg, Germany) placed 2 m above the arena provided light. As an intensity of about 200 lux was needed, two neutral density filters (Lee 211 0.9 ND) were placed on the screen of the projector permitting to obtain a low light intensity at  $220 \pm 5$  lux at the centre on the floor of the arena. The wooden ring also supported an injector ring made of Teflon tubing 6 mm in diameter that supported 12 injector heads equally spaced around the perimeter of the arena. This ring was used to deliver human breath (see procedure below) as a stimulus to activate flies (Fig. 3.1). The breath delivery tube was attached to a pump (Saskia MPC-100E, ILMVAC GmbH, Ilmenau, Germany) placed outside of the environmental cabinet that produced a continuous flow through the injector tube. A webcam (HD C270, Logitech) was placed at 30 cm high on the inner wall of the arena to record landing responses on the visual stimulus made of blue **cloth** (C180 Azur 623, phthalogen blue 100% cotton, 180g/m<sup>2</sup>; TDV Industries, Laval, France) placed at the opposite side (Fig. 3.1). All

tests were performed in the morning, 15 minutes after onset of the photophase for 90 minutes.

*Visual stimuli tested in the arena*

Four visual stimuli (targets) of different shapes having a surface area of 225 cm<sup>2</sup> as tested by Doku and Brady (1989) were used (Fig. 3.2): a 17 cm diameter disk, an equilateral triangle 22.8 cm side, a square 15 cm side and a diamond (square rotated 45°). The goal was to establish landing site preferences by *G. pallidipes* on such targets.

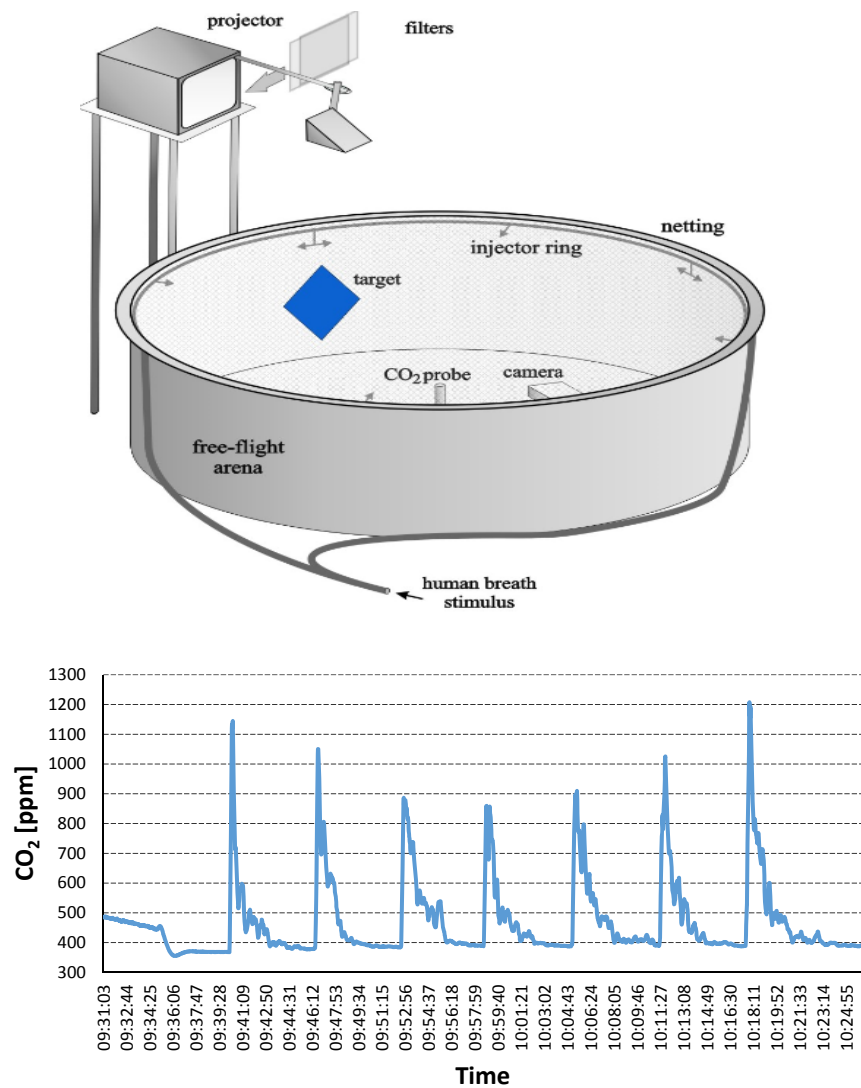

**Fig. 3.1.** Above circular free-flight arena with a visual target suspended on the inner wall; below monitoring of stimulation of flies with human breath in the arena as measured by the CO<sub>2</sub> concentrations delivered over successive experiments. CO<sub>2</sub> was measured using a LI-COR LI-850 CO<sub>2</sub> sensor (LI COR Inc, Lincoln, Nebraska, USA). CO<sub>2</sub> peaks correspond to expirations of the experimenter.

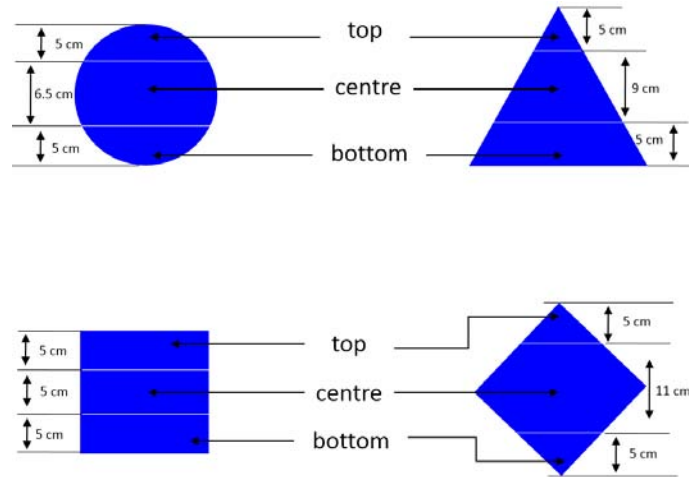

**Fig. 3.2.** Targets (surface area of 225 cm<sup>2</sup>, not to scale) used in the arena and zones on which tsetse landings were recorded.

#### *Test procedure in the arena*

Flies were introduced into the arena the day previous to an experiment, just prior to the scotophase. 15 min before onset of an experiment the pump was switched on allowing flies to habituate to the continuous airflow delivered through the breath delivery tube. The experimenter then stopped the airflow and blew into the tubing for 16 seconds (4 full exhalations) and then reactivated the airflow. The strength of the stimulus was characterised by an increase in the CO<sub>2</sub> concentration in the arena of 880-1200 ppm (Fig. 3.2), as monitored by a LI-COR LI-850 CO<sub>2</sub> sensor (LI COR Inc, Lincoln, Nebraska, USA) continuously sampling air at the geometrical centre of the arena. The experimenter, recording computers and the pump were located outside of the environmental cabinet to prevent unintended sources of stimulation for the flies. One visual stimulus was presented at the time to 15 male *G. pallidipes* in the arena (females were not available). Flies flew after activation with breath and made several landings on the visual stimulus. Landings on targets were recorded for 5 min after stimulation with breath. The breath stimulus was renewed after 6 min of observation (Fig. 3.2). The visual stimulus was replaced during experiments according to the test protocol described in Table 3.1. After three stimulations with breath the first target was replaced by a second, which was replaced after three stimulations by a third one from 7<sup>th</sup> to 9<sup>th</sup> stimulation. Finally the 4<sup>th</sup> target was tested with the last three stimulations (10<sup>th</sup> to 12<sup>th</sup>) with breath. These experiments were repeated four times (over four days) both for 8 day-old fed and for 2-3 day-old teneral flies with a new group of 15 flies per experiment and a new order of

succession of visual target presentation (Table 3.1). A dozen landing counts per target (3 stimulations per treatment x 4 days) both for fed and for teneral flies were available for analysis.

**Table 3.1: Test protocol and randomisation of targets tested in the arena over successive days**

	Stimulation	1 <sup>st</sup> day	2 <sup>nd</sup> day	3 <sup>rd</sup> day	4 <sup>th</sup> day
<b>Target 1</b>	1-3	triangle	disk	diamond	square
<b>Target 2</b>	4-6	disk	diamond	square	triangle
<b>Target 3</b>	7-9	Diamond	square	triangle	disk
<b>Target 4</b>	10-12	square	triangle	disk	diamond

#### *Analysis of landing responses in the arena*

Videos analysis of landing responses was made using Kinovea software (version 0.8.15). With this software it was possible to split targets virtually into three parts (bottom, middle and top; Fig. 3.1) while video recordings are being evaluated. As flies did not stay long on visual objects (less than 5 s) during the 4 first minutes after a stimulation with human breath, the numbers of flies that stayed more than 30 s on objects during the last minute (5<sup>th</sup> minute) after stimulation was counted in order to elucidate resting sites preferences on visual targets in the arena.

#### *The wind tunnel*

The wind tunnel has already been described by Gurba et al. (2012) and Chappuis (2013). The climatized wind tunnel (working area: 250 cm long 100 × 100 cm) is made of non-reflecting glass. A centrifugal ventilator moves the humid and temperature controlled air (65±1% RH, 26°C) across the tunnel at 0.4 m.s<sup>-1</sup> through active charcoal cartridges placed at either end of the working area (Fig. 3.3). On both side walls of the wind tunnel light blue vertical bands 7 cm wide spaced 7 cm apart provided visual cues to enable tsetse to orient. To ensure that tsetse perceived the blue bands, band width was calculated as 2.5 times the

interommatidial angle in the peripheral eye zone at 1 m as measured by Gibson and Young (1991). To increase the contrast between the floor and the flying insect, a diffuse red light was placed under the floor of the wind tunnel made of glass. This light was generated by a panel of LEDs (Luniscontrol GmbH, Lanzenhäusern, Bern, Switzerland) covered with ground glass and with a light filter (Roscolab Ltd., Schloss Holte-Stukenbrock, North Rhine-Westphalia, Germany) with a cut-off at 600 nm. In all experiments a laminar air flow was produced through a perforated steel screens (1 mm thick, 3 mm round holes, 51% of air passage) covered with white mosquito netting (nylon, 1 mm mesh) placed upwind and a white nylon laminar flow screen (50  $\mu$ m mesh) at the downwind end of the wind tunnel. Overhead illumination was provided by high frequency neon tubes (1 kHz, Luniscontrol GmbH, Lanzenhäusern, Bern, Switzerland) 186 cm above the tunnel floor and running the length of the tunnel in two groups of 4 tubes 27 cm apart in a housing 120 cm wide (with fans to eliminate heat). The high frequency tubes provided a light intensity of  $300 \pm 5$  lux measured at the middle on the floor of the wind tunnel. Human breath was used to stimulate flies (Gurba et al., 2012, Chappuis, 2013) and was collected from one individual (a male Central African experimenter, 29 years old) and no attention was paid to his diet. The experimenter expired via a Teflon<sup>®</sup> tube into a 25L Tedlar gas-sampling bag (CELScientific corp, Santa Fe Springs, California, USA) that was held at room temperature. The sampling bag was connected to a pump (Saskia MPC-100E, ILMVAC GmbH, Ilmenau, Germany) which pumped breath into the tunnel through a flow meter (Solartron Mobrey, Chanhassen, Minnesota, USA). The pump was connected to a variac (Philips, Amsterdam, Nordholland, Netherland) to adjust the flow rate to 15 L/min as indicated by Chappuis (2013). The odour plume entered in the wind tunnel through a gas mixers housed in a steel tube 26 cm in diameter. The laminarity of the airflow was controlled by (Chappuis, 2013) by measuring wind speeds and by visualizing the airflow with a plume of ammonium acetate. This confirmed that the plume maintained its shape (tube 26 cm diameter) along the wind tunnel length. Mean CO<sub>2</sub> increases with breath was from  $390 \pm 10$  to  $790 \pm 15$  ppm at the release cage position. The variac was set up near the experimenter, allowing him to switch on the pump, activate the video recording and the tracking system and open the release cage within 5s.

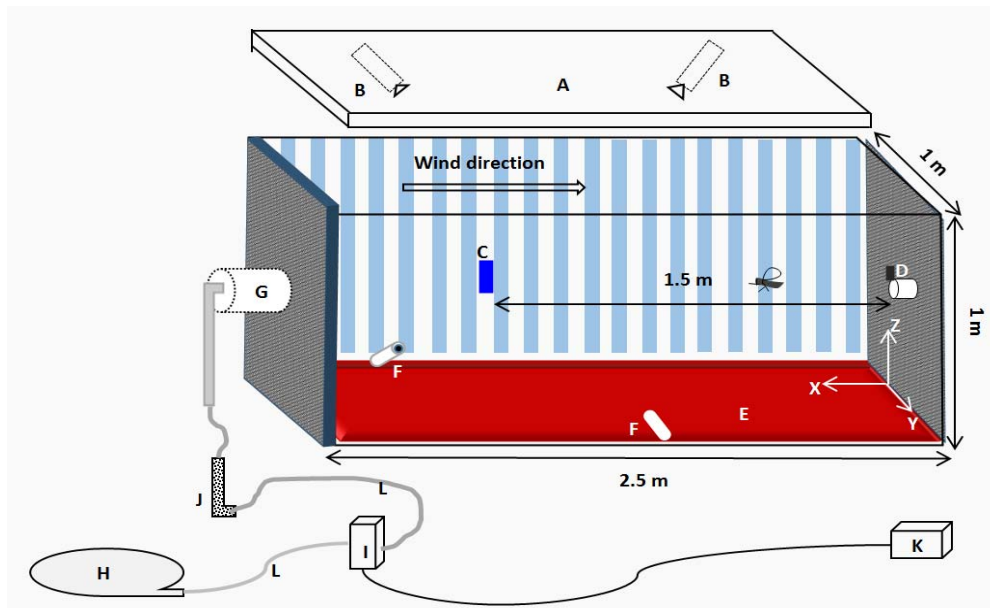

**Fig. 3.3.** Scheme of the wind tunnel (modified from Chappuis, 2013), not to scale. **A** High frequency neon lighting; **B** Cameras of the tracking system in the middle of the overhead lighting field **A**; **C** visual target; **D** Fly release cage; **E** Floor lighting by a panel of LEDs covered by a filter cutting out light below 600nm; **F** Web cams to record fly landing responses; **G** Static gas mixers housed in a steel tube; **H** Gas-sampling Tedlar bag; **I** Pump to push breath into the wind-tunnel; **J** Flow meter; **K** Variac; **L** Breath delivery Teflon tube.

#### *Visual targets tested in the wind tunnel*

2D visual targets were made of blue cloth (described above for experiments in the arena), matt black cloth (100% cotton, 470 g/m<sup>2</sup>; Gubser Textile AG, Schlieren, Switzerland) showing no reflectance below 660 nm (Fig. 2.2a, Chapter 2) and the combination of these cloths (Fig. 3.4). Such black cloth was chosen to provide a strong contrast with the phthalogen blue cloth with regard to the spectral sensitivity of tsetse (Green and Cosens, 1983). All targets were 25 cm x 25 cm in size and were suspended by 0.15 mm diameter transparent nylon fishing line at 1.5 m from the release cage position. According to the tracking system coordinates, the centre of visual targets corresponded to  $x = 1.5$ ,  $y = 0.5$ ,  $z = 0.5$  in meter. To test the hypothesis that weak landing responses on 2D targets is due to a lack of a 3D component, a blue and black 16 cm diameter disks of the cloths described above were tested, and a blue and black sphere made of polystyrene, 16 cm in diameter and painted, respectively, with Gentian blue and matt black (Dupli-color®, MOTIP DUPLI GmbH, Hassmersheim, Germany) were also tested. The reflectance peak of the blue sphere was 460 nm with a shoulder at 410 nm as measured by Chappuis (2013).

*Improvement of landing responses of G. pallidipes on 2D visual targets by incorporating a 3D landing stimulus*

*G. pallidipes* landed on the bottom and the centre of 2D targets in the arena (Fig. 3.6) and flies flew mostly around the bottom of visual targets in the wind tunnel (Fig. 3.12). Flies also showed interest for resting on the undersides of horizontally-suspended bars during the photophase (chapter 2). Moreover, it was obvious that 3D objects (blue and black spheres) enhance landings by *G. pallidipes* (Fig. 3.14). We hypothesised that incorporating resting site characteristics (horizontal features and a 3D aspect) to 2D visual targets would enhance landing responses by tsetse on such targets. To improve efficacy of 2D targets at inducing landings by *G. pallidipes* a second series of experiment was made with the 25 cm x 25 cm all-blue square incorporating, at the base, a 1.5 cm diameter wooden round bar covered with black cloth above (Fig. 3.4). The black round bar was chosen to represent resting sites characteristics of tsetse (Chapter 2) and was tested as a 3D landing stimulus on the 2D blue target. Such a target was chosen as it is the best tested in the field (Green, 1988, Lindh et al., 2009, Rayaisse et al., 2011, Tirados et al., 2015). To test the effect of the form of the landing stimulus, an equilateral triangular bar (1.5 cm height) covered with the same black cloth as above (Fig. 3.4) was added at the base of the all-blue square for testing. To ensure that the 3D aspect of the added landing stimulus could influence the landing response by *G. pallidipes*, a 2D object was created for comparison with 25 cm x 1.5 cm rectangular black stripe made of the black cloth above and placed horizontally at the bottom edge of the blue square (Fig. 3.4). For further investigation on the synergy between the blue and black contrast and the 3D aspect of an object at inducing landing by tsetse, the all-blue with a 1.5 cm diameter blue bar at the base was also tested.

**2D visual targets**

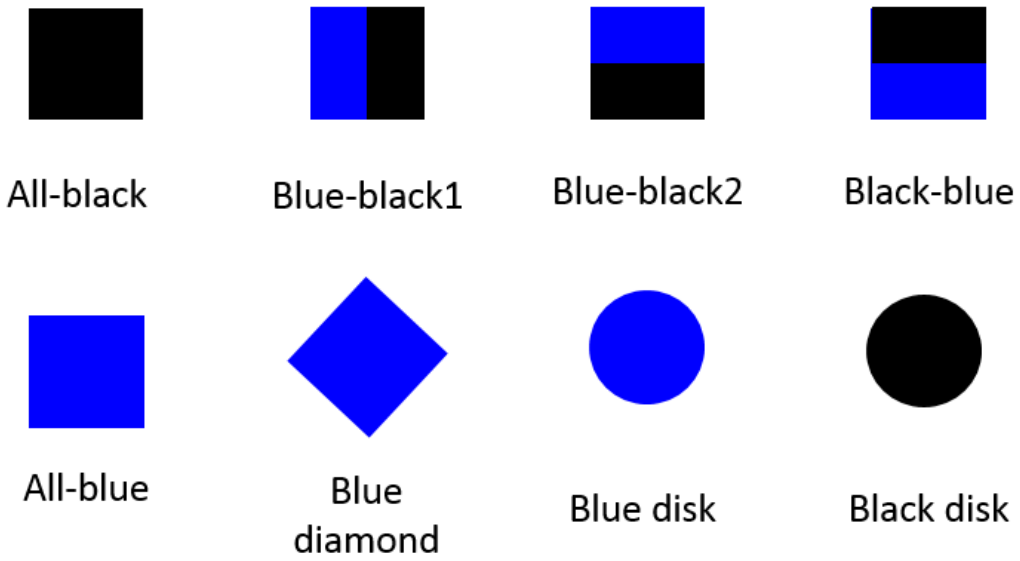

**2D visual targets incorporating a 3D landing stimulus at the base**

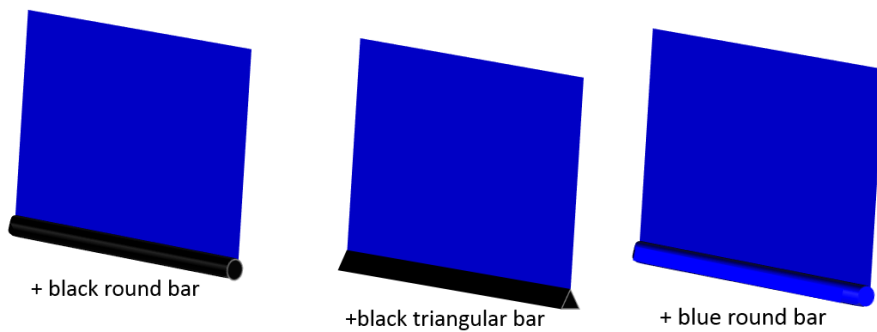

**2D visual target incorporating a black 2D stripe at the base**

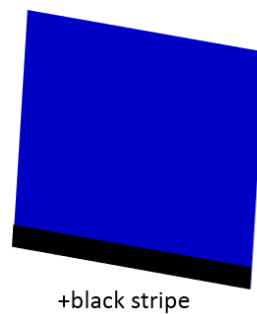

**Fig. 3.4.** Visual targets tested in the wind tunnel. All square targets were 25 cm x 25 cm and disks were 16 cm in diameter. The black and the blue round bar were 1.5 cm in diameter, the equilateral triangular bar was 1.5 cm high and the black stripe was 25 cm x 1.5 cm.

### *Tracking system*

The flight of tsetse was filmed and recorded at 24 frames per second by two video cameras (eXcite exA640-120m, Basler, Ahrensburg, Schleswig-Holstein, Germany) with wide angle objectives (SV M0614, C mount, f=6 mm, VS Technology, Tokyo, Japan) linked to 3D software (v7.1, MVTec, München, Bayern, Germany) placed 87cm above the wind tunnel (distance between cameras 160 cm) and linked to a computer (Chappuis, 2013, Gurba et al., 2012). The programme (CrowCameras, University of Neuchâtel, Neuchâtel, Switzerland) calculates the x, y, and z coordinates of each point of flight to determine the location of the fly within the wind tunnel at a given time at a sampling rate of 10 points per second. In addition, two cameras (webcam HD C270, Logitech, Suzhou, China) covered with aluminium paper were set on the floor at the sides walls of the wind tunnel to monitor landings on targets (Fig. 3.3).

### *Test procedure in the wind tunnel*

12 plastic release cages (transparent PVC cylinders 13 cm × 5 cm) were used with one end cut out and replaced by a nylon mesh netting disk 5 cm in diameter, the other end equipped of a sliding metal door. 12 flies were transferred into separate release cages. The cages were placed on the floor at the downwind end of the wind tunnel and covered by a brown box to prevent visual contact by the flies with the tested target. The test procedure was as follows: after 20 min of acclimatization in the wind tunnel conditions (26°C, 65% RH) the first cage was placed horizontally on a stand at 50 cm from the floor and at 5 cm from the downwind end of the wind-tunnel with the claps facing the upwind end. A 1 mm diameter fishing line of which one end is connected to the clasp of the release cage, the other end comes outside through a pulley and a space between the gate and the wind tunnel ceiling. The fishing line allows the experimenter to lift the cage by pulling it from the outside when the doors of the flight chamber are closed during the experiment. The tracking system and a stopwatch were launched (time 0), and the pump was switched on to deliver human breath into the main wind tunnel air flow. The sliding door of the cage was lifted and the flight recording systems were activated. The pump was switched off after 10 s. The duration of an experiment depended on the duration of insect flight. One *G. pallidipes* was released per observation and a tested fly was not used again in the wind tunnel. In the first series of experiments with 2D

targets and spheres, 60 *G. pallidipes* was tested per object in order to establish flight behaviour and landing responses of flies on such visual targets. In the second series of experiments with 2D targets incorporating a 3D landing stimulus at the base, the number of flies tested per target was increased to more than one hundred in order to obtain sufficient numbers of landing responses for a better analysis of subsequent landings and landing site predilection on targets.

#### *Flight track and landings analysis*

In these experiments we were interested mainly in the behavioural responses of tsetse when they were flying towards and around visual targets and in their landing responses. Straightness, height and velocity were parameters used for characterizing the upwind flights to targets. Straightness was calculated from the distance covered by the fly during the flight up to the target as follows:

$$D = \sum_{i=start}^{current-1} |P_{i+1} - P_i|$$

where  $D$  is the total distance covered, i.e. the sum of the distances between the successive insect positions recorded ( $P$ ) and

$$r = \frac{|P_{current} - P_{start}|}{D_{current}}$$

where  $r$  is the flight straightness recorded, the quotient of the length of a straight line between the start position and the current position of the insect, divided by the total distance covered by the insect. An index of 1 indicates a perfectly straight track. Velocity was defined as the instantaneous speed of the insect:

$$v = \frac{d(D_{current})}{d(T_{current})}$$

To quantify flights around a visual target, an ellipsoidal area of radius  $R_1 = 35$  cm and  $R_2 = 30$  cm was delimited around the target and called the “vicinity of the target” (Fig. 3.5a) and R software version 3.2.2 (R Core Team, 2016) was used to select positions of flies

generated by the tracking system. To assess the predilection for flights around the lower part of targets, three flight zones in the vicinity of the target was considered (Fig. 3.5b): lower part (25 cm in height) covering a space 17,5cm in height below the lower edge of the 2D target, middle part of the visual target (10 cm in height), and upper part (25 cm in height) covering a space 17.5 cm high above the upper edge of the visual target. To record landing on different parts of a target the Kinovea software (version 0.8.15) was used to split the target into three parts (Fig. 3.5c): bottom (5cm in height), centre (15 cm in height) and top (5cm in height). The expression “subsequent landing response” used in the Results refers to landings that were made several times (at least twice) by a same fly and this was calculated for each target as the proportion of total landing flies as follows:

$$\text{Subsequent landing response (\%)} = \frac{\text{Number of flies that landed at least twice} \times 100}{\text{Total number of landing flies}}$$

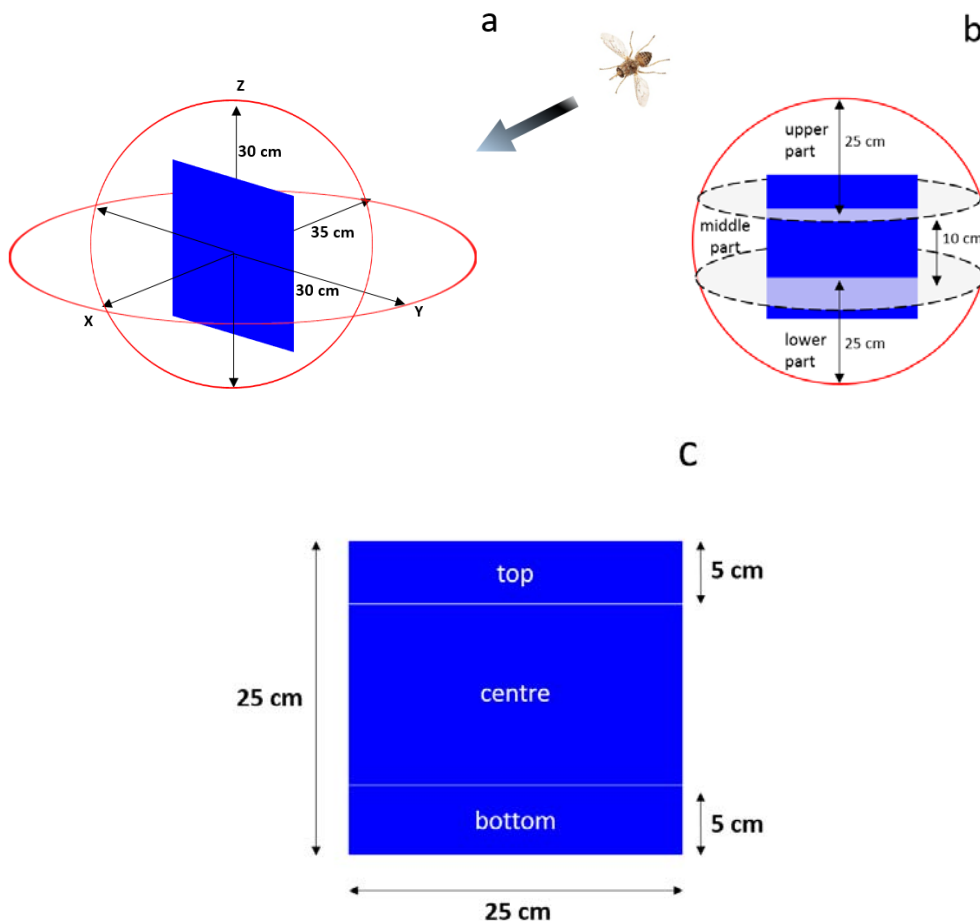

**Fig. 3.5.** (a) and (b) Representation of defined zones in which fly behaviour was recorded in the vicinity of the visual targets in the wind tunnel; (c) Landing sites defined on the visual target (example of the all-blue square target).

### *Statistics*

All statistical tests were performed using R software version 3.2.2. (R Core Team, 2016). Upwind flights parameters (straightness, height and velocity) between tested targets were compared using analysis of variances (ANOVA) followed by the Tukey HSD test when variances were homogeneous. In the case of heterogeneity of variances a generalized linear model (GLM) with a logit link function (gamma family) was used. Proportions of flights of different heights in the vicinity of a target were analysed using a GLM with Poisson errors. Landing responses were compared between targets using a GLM with binomial errors. A multinomial logistic regression ([www.ats.ucla.edu/stat/r/dae/mlogit.htm](http://www.ats.ucla.edu/stat/r/dae/mlogit.htm), date last visited 10.06.2016) was used to compare proportions of subsequent landings on different parts of targets.

### 3.3. Results

#### *Landing site preferences of G. pallidipes on 2D targets in the arena*

Data were pooled for teneral and fed flies as there was no influence of the nutritional status on landing sites preferences on targets (multinomial logistic model,  $P>0.05$ ). For the triangle,  $13.5\pm 1.2$  landings were on its bottom, significantly high compared to  $4.3\pm 0.8$  and  $1.7\pm 0.5$  landings, respectively, for the middle and the top ( $P<0.0001$ ; Fig. 3.6). This pattern was similar for the diamond, with  $11.6\pm 1$  landings on the bottom compared to  $7.8\pm 0.9$  and  $1.6\pm 0.5$  landings, respectively, for the middle ( $P<0.005$ ) and the top ( $P<0.0001$ ). For the disk and the square no difference in number of landings into the bottom and middle was found (multinomial logistic model,  $P>0.05$ ; Fig. 3.6). For all objects, significantly few landings occurred on the top ( $P<0.0001$ ). *G. pallidipes* rested mostly on the bottom of the triangle, with  $1.7\pm 0.3$  resting flies on the bottom compared to  $0.9\pm 0.3$  and  $0.2\pm 0.1$  flies, respectively, resting on the middle and the top (multinomial logistic model,  $P<0.0001$ ; Fig. 3.6). For the disk, the diamond and the square, numbers of resting tsetse were equal on the middle and the top ( $P>0.05$ ). Few flies rested on the top in the presence of any object ( $P<0.0005$ ; Fig. 3.6).

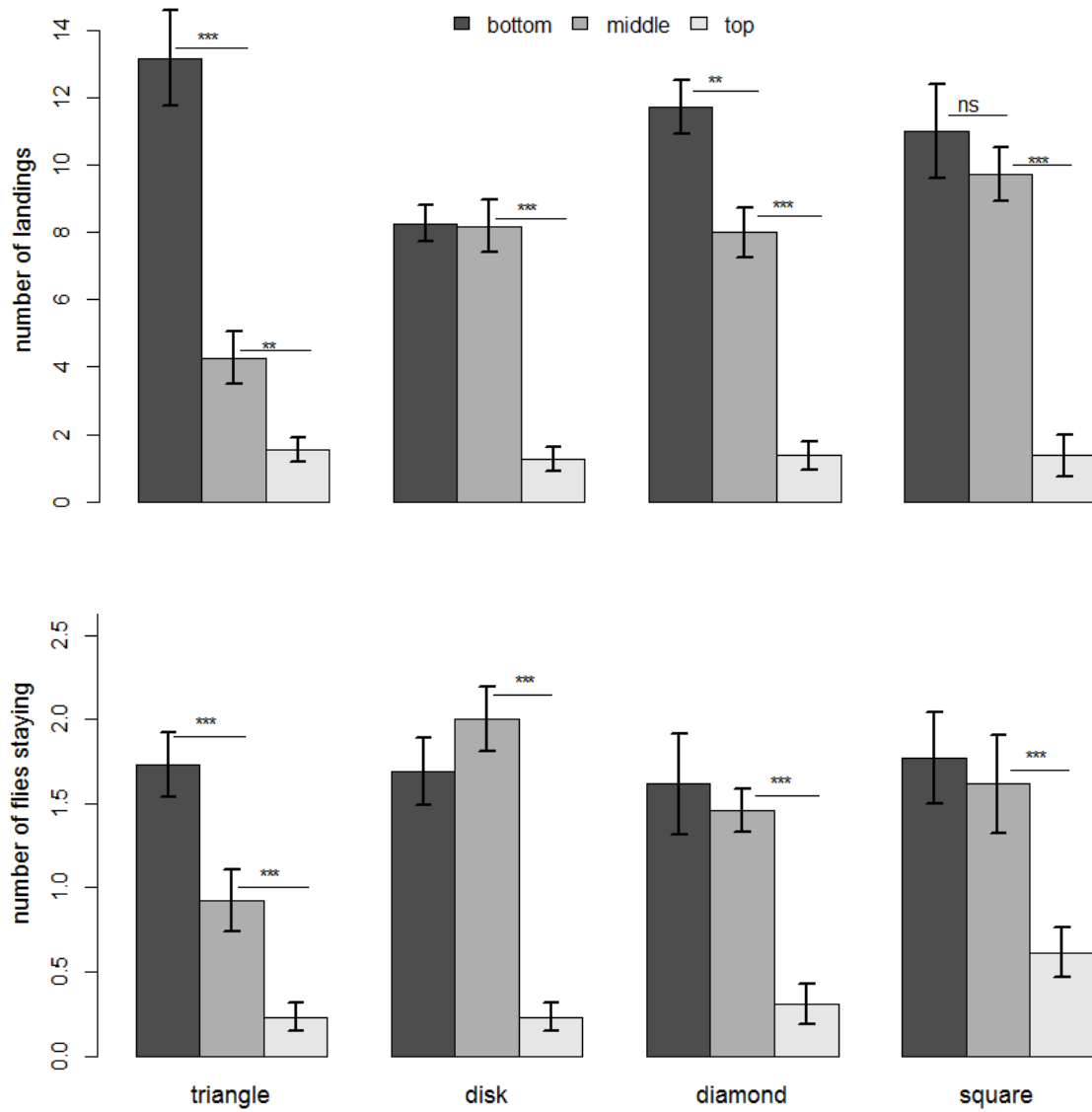

**Fig. 3.6.** Bar plots of numbers (mean  $\pm$  SEM,  $n = 24$  repetitions) of male (teneral and fed) *G. pallidipes* that landed on different parts of visual targets in the arena after activation with human breath (**top** numbers of flies counted within 4 min of activation; **bottom** number of flies staying more than 30 s during the fifth minute of observations). Asterisks indicate significant differences between landing sites on the same object (multinomial logistic model,  $**P < 0.005$ ;  $***P < 0.0001$ ). Data were pooled for teneral and fed tsetse as no influence of nutritional status was found on the choice of landing sites ( $P > 0.05$ ).

*Characteristics of G. pallidipes upwind flights towards visual targets in the wind tunnel*

Of a total of 60 tested for each target all flies took off and flew to targets, but only between 38 and 51 flights were suitable for analysis. Thirty flights were analysed without a visual target. For the analysis of landings responses, all 60 flies per target were considered. In the Y plane that represents the zigzag in flights, *G. pallidipes* generally flew symmetrically along the central axis of the wind tunnel and flights followed a Gaussian distribution centred on the y-axis along the wind tunnel, with and without a visual target present (Anderson-Darling normality test,  $P < 0.001$ ; Figs. 3.7, 3.8, 3.9 and Fig. 3.10, top view). The type of visual target did not influence upwind flight straightness by *G. pallidipes*, with straightness indexes in the range of  $0.91 \pm 0.02$  -  $0.96 \pm 0.025$  (GLM with Gamma errors,  $P > 0.05$ ; Fig. 3.11). The straightness index significantly dropped to  $0.83 \pm 0.04$  when visual target was present ( $P < 0.05$ ; Fig. 3.11). The upwind flight velocity was statistically similar in the presence of all visual targets and was in the range  $1.43 \pm 0.1$  –  $1.6 \pm 0.8 \text{ ms}^{-1}$  (GLM with Gamma errors,  $P > 0.05$ ; Fig. 3.11). The upwind flight speed of *G. pallidipes* was slightly faster when no target was present with a mean speed of  $1.7 \text{ ms}^{-1}$  but this was not statistically different from that recorded in the presence of targets (GLM with Gamma errors,  $P = 0.06$ ). The analysis of heights of flights (in the Z plane) showed that tsetse flew significantly higher when no target was present, at an average height of  $0.46 \text{ m} \pm 0.29$  compared to  $0.36 \pm 0.02$  –  $0.385 \pm 0.02 \text{ m}$  when any visual target was present (GLM with Gamma errors,  $P > 0.05$ ; Fig. 3.11). The type of target did not influence the height of upwind flights by *G. pallidipes* in the wind tunnel ( $P > 0.05$ ).

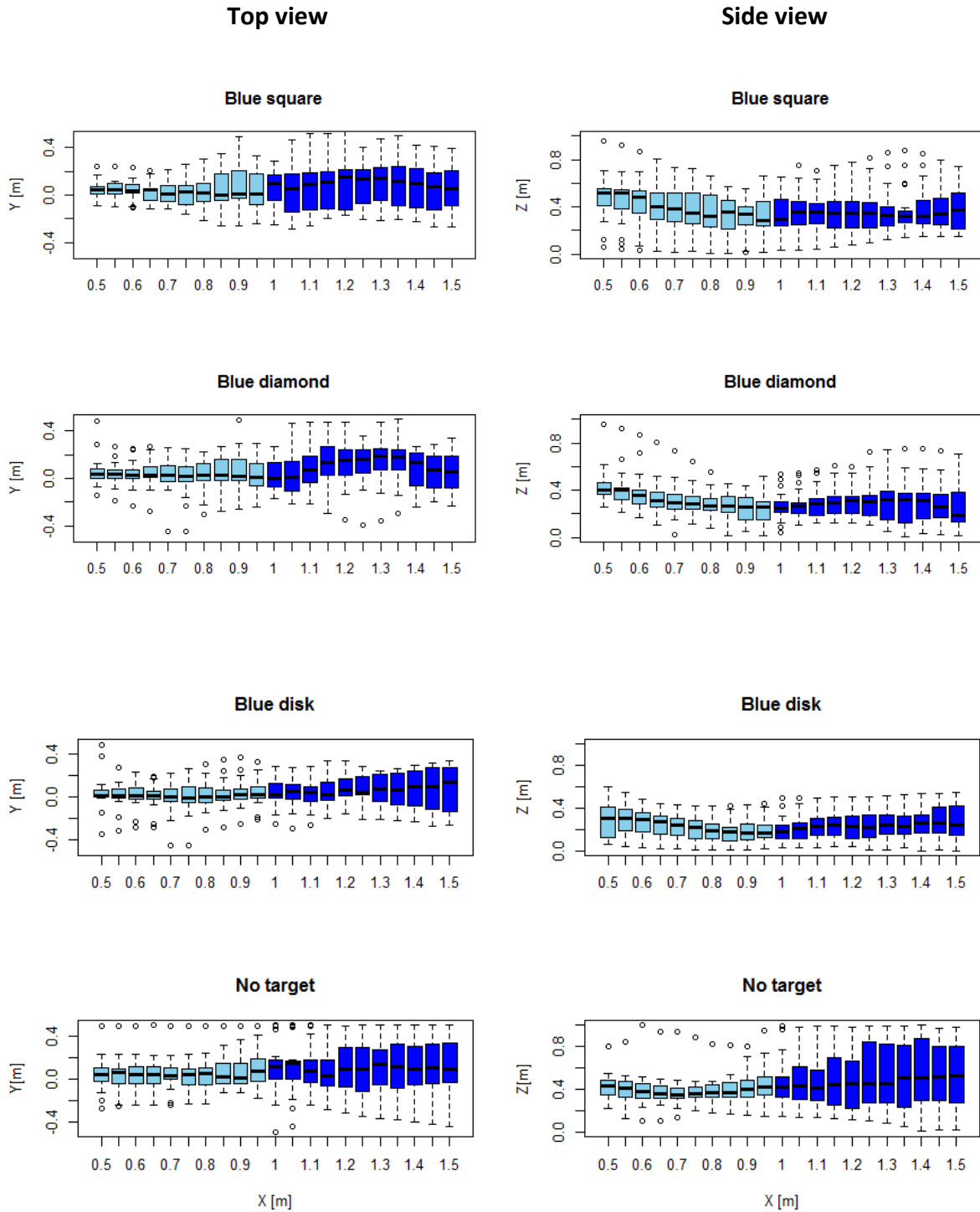
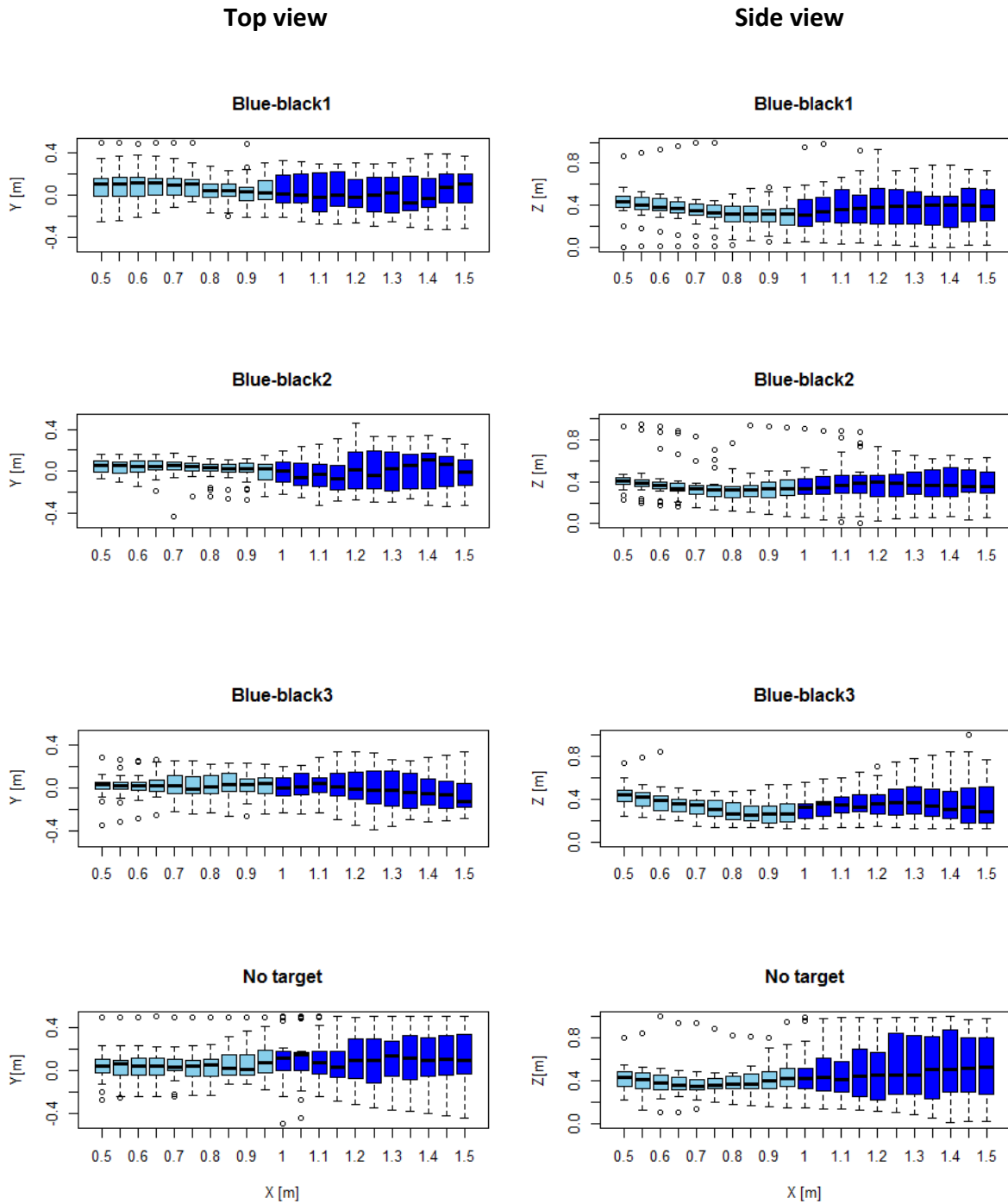
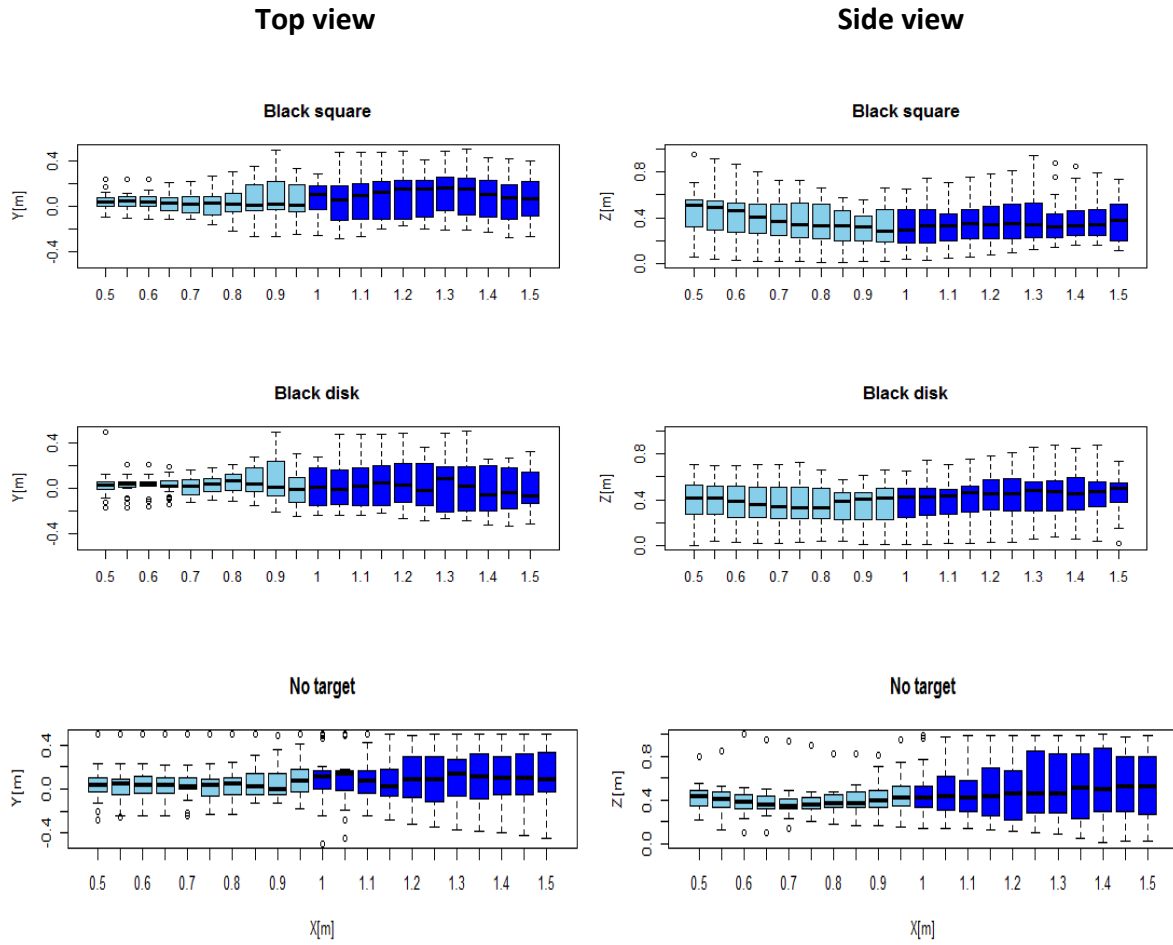

Fig. 3.7. Representations of *G. pallidipes* upwind flights over 1 m in the wind tunnel in the presence of blue 2D targets ( $n = 50, 42$  and  $45$  flights, respectively, for the square, the diamond and the disk) and in the absence of a visual target ( $n = 30$  flights). Each fly was tested only once. Targets were placed at 1.6 m (0.5 m above the floor) from the initial position of the fly and the tracking system began at 0.5 m beyond this point. Each box plot represents the median, minimum, maximum and the 25<sup>th</sup> - 75<sup>th</sup> quartiles of flight track positions.



**Fig. 3.8.** Representations of *G. pallidipes* upwind flights over 1 m in the wind tunnel in the presence of bicoloured 2D targets ( $n = 44, 47$  and  $45$  flights, respectively, for blue-black1, blue-black2 and black-blue) and in the absence of a visual target ( $n = 30$  flights). Each fly was tested only once. Targets were placed at 1.6m (0.5 m height) of the initial position of the fly and the tracking system began at 0.5 m beyond this point. Each box plot represents the median, minimum, maximum and the 25<sup>th</sup> - 75<sup>th</sup> quartiles of flight track positions.



**Fig. 3.9.** Representations of *G. pallidipes* upwind flights over 1 m in the wind tunnel in the presence of black 2D targets ( $n = 48$  and  $38$  flights, respectively, for the square and the disk) and in the absence of a visual target ( $n = 30$  flights). Each fly was tested only once. Targets were placed at 1.6 m (0.5 m height) of the initial position of the fly and the tracking system began at 0.5 m beyond this point. Each box plot represents the median, minimum, maximum and the 25<sup>th</sup> - 75<sup>th</sup> quartiles of flight track positions.

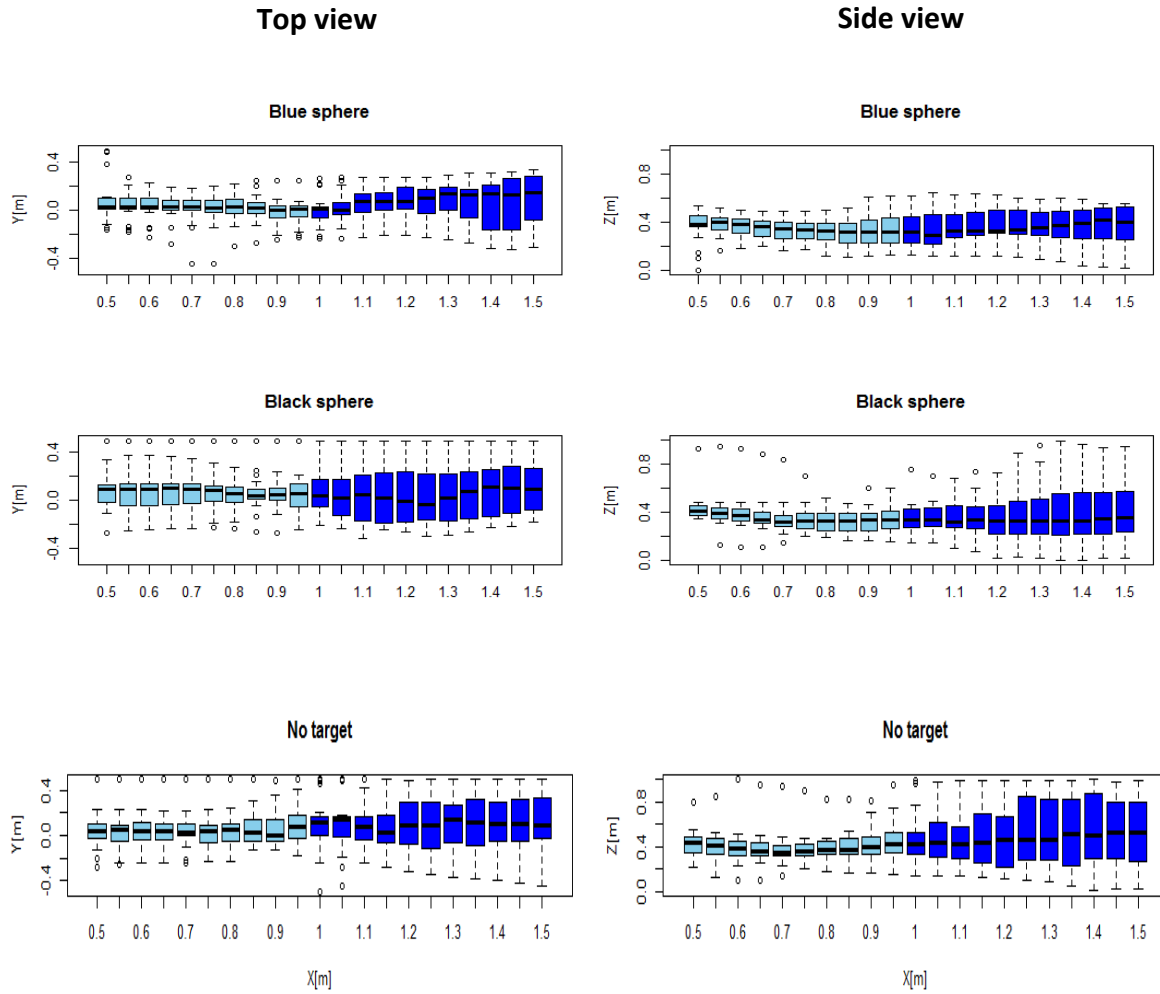

**Fig. 3.10.** Representations of *G. pallidipes* upwind flights over 1 m in the wind tunnel in the presence of 3D targets (n = 51 and 40 flights, respectively, for the blue and the black sphere) and in the absence of a visual target (n = 30 flights). Each fly was tested only once. Targets were placed at 1.6 m (0.5 m height) of the initial position of the tested fly and the tracking system began at 0.5 m beyond this point. Each box plot represents the median, minimum, maximum and the 25<sup>th</sup> - 75<sup>th</sup> quartiles of flight track positions.

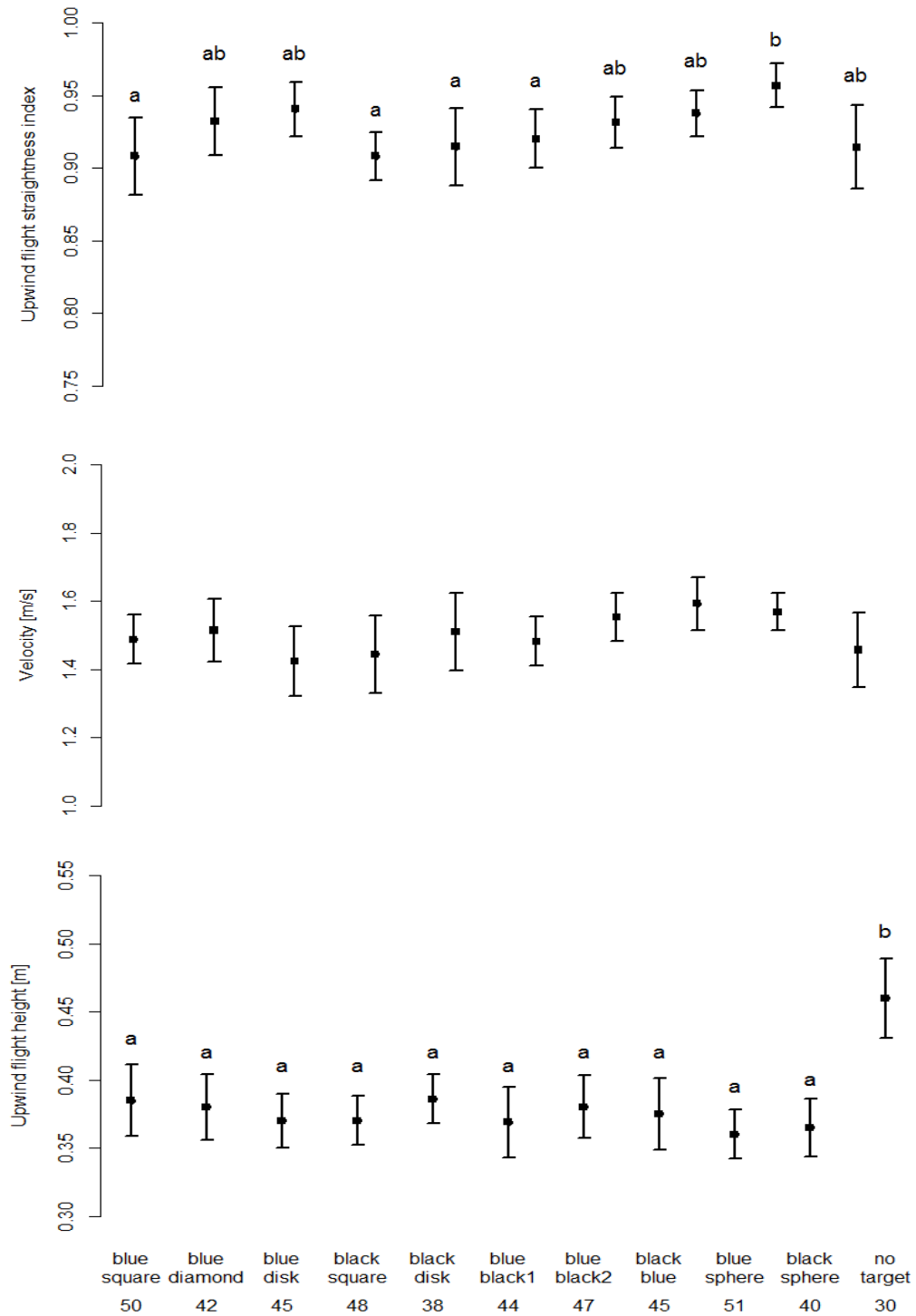

**Fig. 3.11.** Mean  $\pm$  SEM of straightness indexes, velocities and heights of upwind flights made by *G. pallidipes* over 1 m in the wind tunnel in the presence and absence of a visual target. Numbers below targets tested are number of flights analysed (each fly was tested one time). Values with different letters are statistically different; ns = non-significant (GLM with Gamma errors, level of probability 0.05).

*Flights around visual targets by G. pallidipes in the wind tunnel: height and length*

*G. pallidipes* flew lower in the vicinity of visual targets in the wind tunnel (Fig. 3.5), with lower flight proportions ranging from  $69.5\% \pm 4$  to  $84.6\% \pm 6$  (Fig. 3.12). Proportions of flights around the middle and upper parts of targets were in the range of  $9 \pm 2$  –  $18 \pm 3\%$  and  $6 \pm 2.6$  –  $15 \pm 3\%$ , respectively, significantly low compared to corresponding flight proportions around the lower parts of targets (GLM with Poisson errors,  $P < 0.0001$ ). In the absence of a visual target, turning flights occurred mainly in the middle (36.5%) and the upper part (39.5%) of the space in the vicinity of targets ( $P < 0.05$ ; Fig. 3.12).

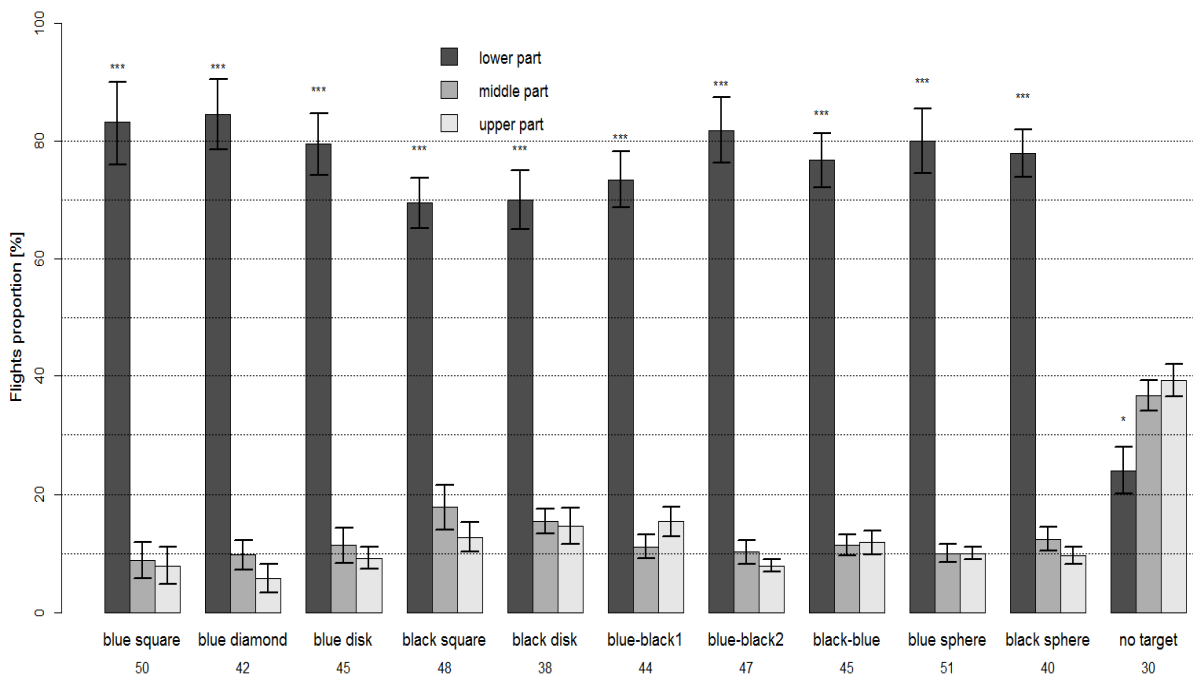

**Fig. 3.12.** Mean  $\pm$  SEM of proportions of flights made by *G. pallidipes* around visual targets in the wind tunnel and in the space occupied by visual targets for tests made with no upwind object. Numbers below targets are number of flights analysed (each fly was tested one time). Asterisks indicate significant differences between lower and other parts of flights made in the vicinity of the same object and in the absence of an object (GLM with Poisson errors, \* $P < 0.05$ , \*\*\* $P < 0.0001$ ).

The length of flights around targets was similar for blue 2D targets (square, diamond and disk) and for bicoloured targets (blue-black1 and 2, and black-blue) with distances ranging from  $5.8 \pm 0.36$  to  $6.8 \pm 0.4$  m (GLM with Gamma errors,  $P > 0.05$ ; Fig. 3.13). These distances were significantly high compared to  $3.8 \pm 0.6$  and  $2.95 \pm 0.5$  m, respectively, for the black square and black disk ( $P < 0.005$ ). Nevertheless, the most persistent flights were in the presence of 3D targets, with distances of  $8 \text{ m} \pm 0.3$  and  $7 \text{ m} \pm 0.45$ , respectively, for the blue and black spheres ( $P < 0.05$ ; Fig. 3.13).

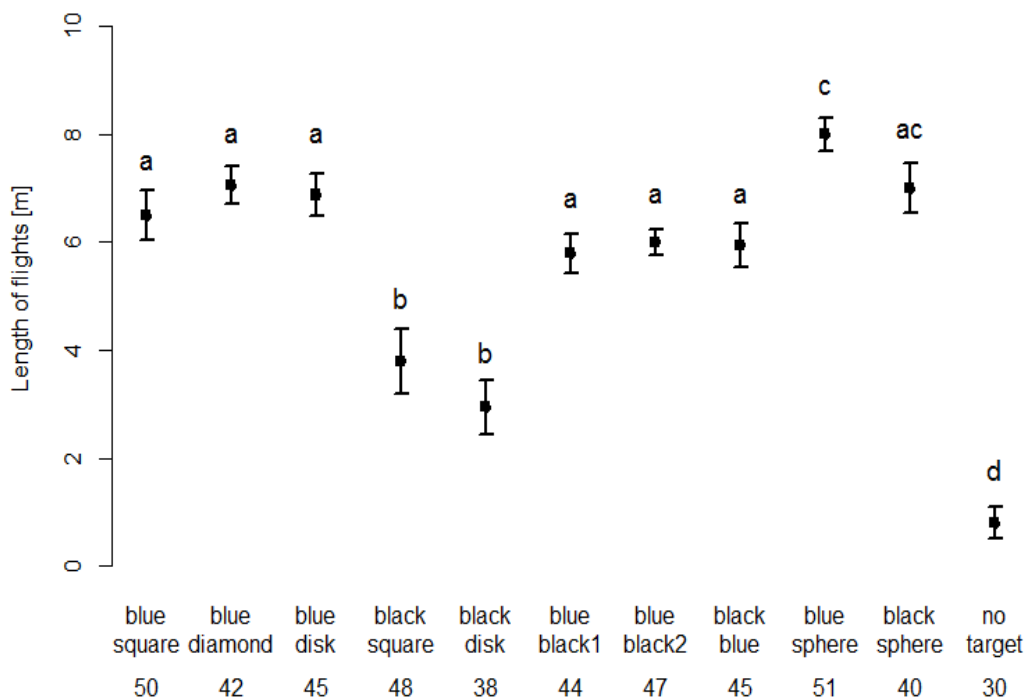
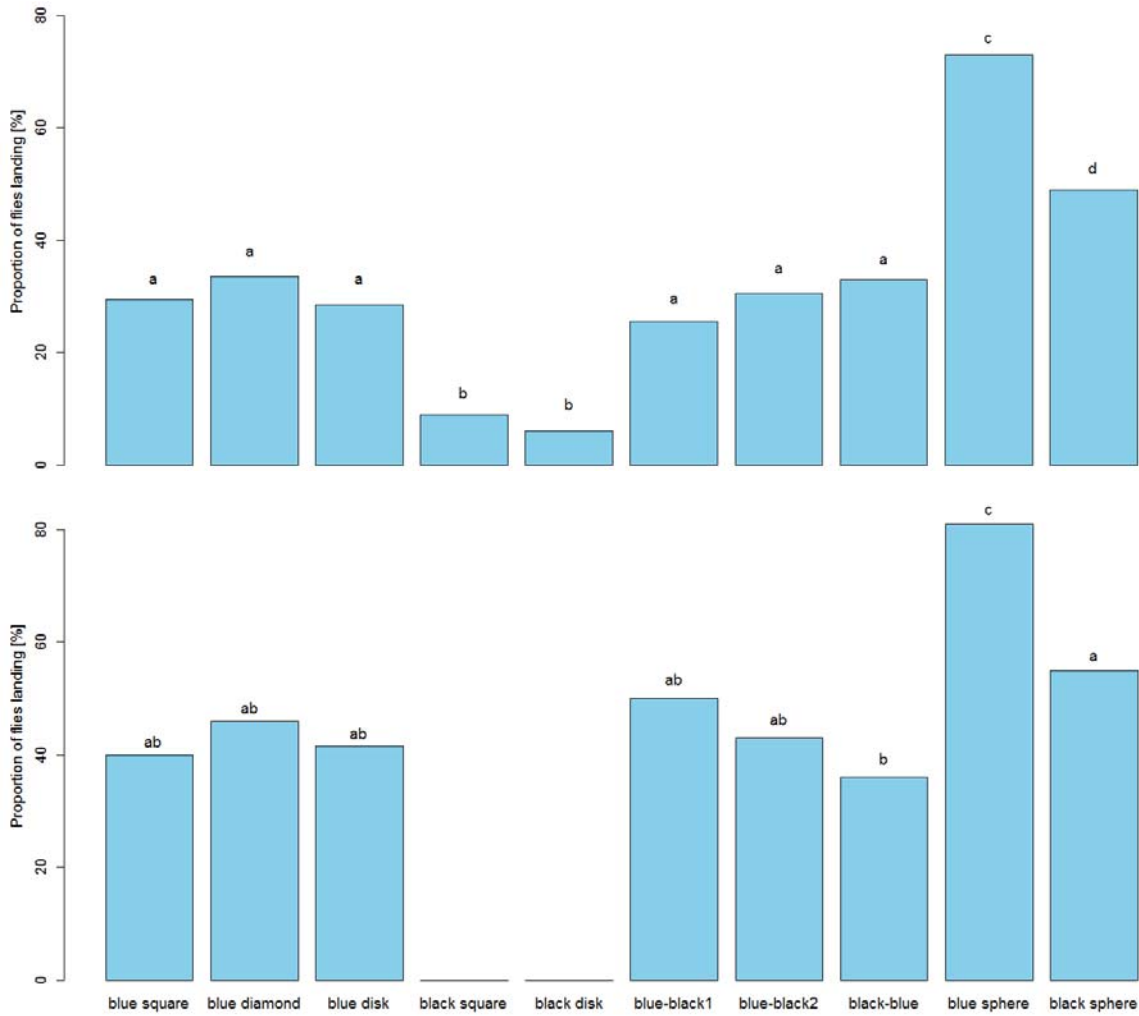

**Fig. 3.13.** Distance covered (mean  $\pm$  SEM) by *G. pallidipes* in the vicinity of visual targets tested in the wind tunnel and in the space occupied by visual targets for tests made with no upwind object. Numbers below targets are number of flights analysed (each fly was tested one time). Means with the same letter are statistically the same (GLM with Gamma errors, level of probability 0.05).

*Landing and subsequent landing responses of G. pallidipes on visual targets tested in the wind tunnel*

The landing response was similar on blue and bicoloured 2D targets and was in the range of 25.5 - 33.5% (GLM with binomial errors,  $P>0.05$ ; Fig. 3.14). When 2D black targets were presented to *G. pallidipes*, landings significantly dropped to 9 and 6%, respectively, for the black square and the black disk (GLM with binomial errors,  $P<0.005$ ; Fig. 3.14). Highest landing scores were recorded on the blue and black spheres, with, respectively, 73% ( $P<0.005$ ) and 49% ( $P<0.05$ ) of landing flies compared, for example, to 33.5% for the blue diamond supporting the notion that 3D objects are more efficient at inducing landings by tsetse. All *G. pallidipes* landed on the underside of spheres. For the three bicoloured 2D targets >70% of first landings were recorded on the blue portion of targets irrespective of the position of the blue (above or below).

The subsequent landing response by *G. pallidipes* was statistically the same (36 – 45%) on blue and bicoloured 2D targets (GLM with binomial errors,  $P>0.05$ ; Fig. 3.14). No subsequent landings was recorded when black 2D targets were presented to the flies (Fig. 3.14). The subsequent landing score by *G. pallidipes* on the blue sphere was higher compared to that on 2D targets ( $P<0.001$ ) and to that on the black sphere ( $P<0.05$ ).

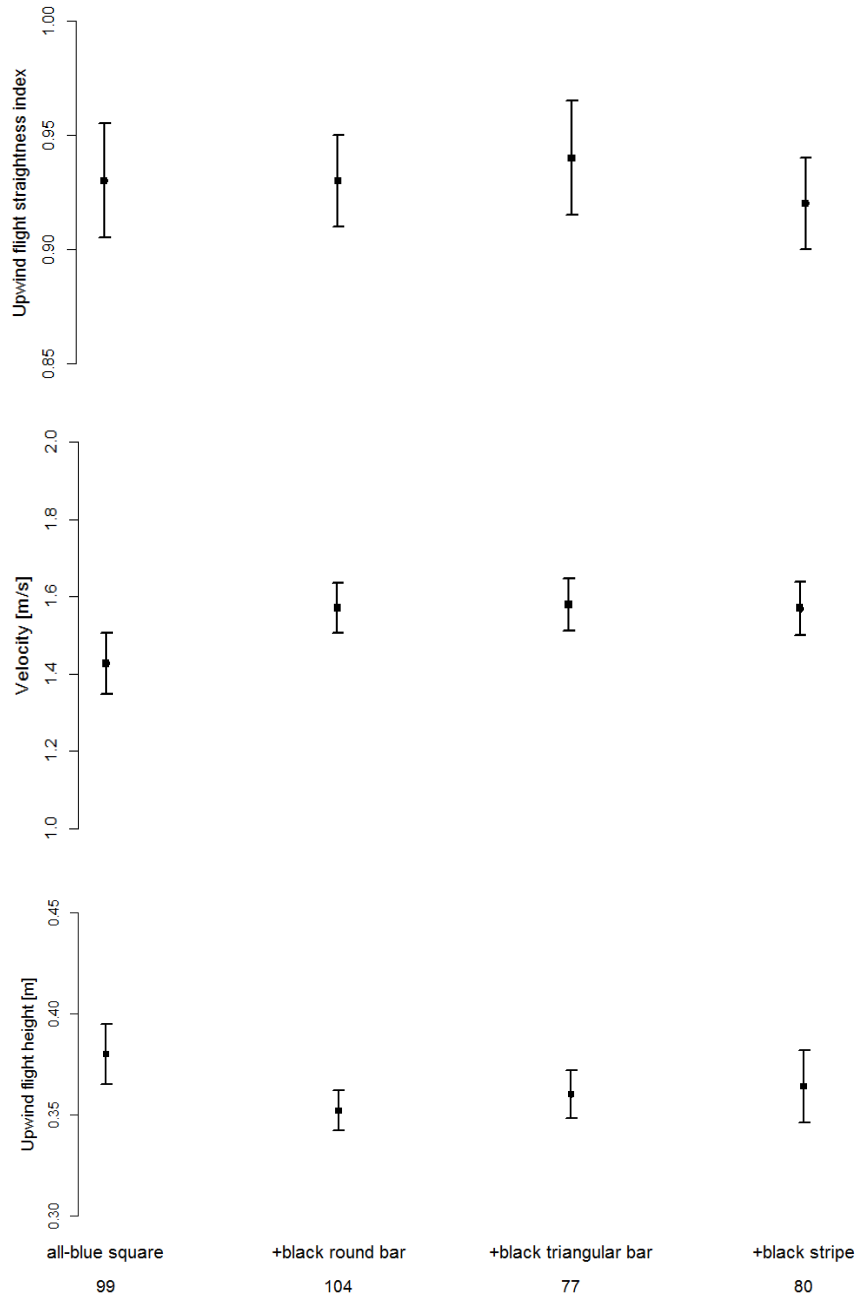

**Fig. 3.14. Top** Landing and **Bottom** subsequent landing responses by *G. pallidipes* on different targets tested in the wind tunnel. 60 flies were tested for each target. Bars plots with same letters are statistically no different (GLM with binomial errors, level of probability 0.05).

*Upwind flights of G. pallidipes towards 2D visual targets incorporating a landing stimulus in the wind tunnel*

A total of 187, 175, 118 and 128 flies (males and females) were tested, respectively, for the all-blue target, blue with black round bar, blue with black triangular bar and blue with a black stripe and, respectively, 99, 104, 77 and 80 flights were suitable for analysis. 47 flies were tested in the presence of the blue target with the blue round bar at the base only for the matter of comparison of landing responses. Data were pooled for all flies as no effects of sex and nutritional status (teneral or fed) were found for the upwind flight straightness and upwind heights (ANOVA followed by a Tukey HSD test,  $P > 0.05$ ), for flight heights around targets (ANOVA followed by a Tukey HSD test,  $P > 0.05$ ) or for the landing responses on targets

(GLM with binomial errors,  $P>0.05$ ). The straightness of *G. pallidipes* upwind flights to targets was not influenced by the target types, with straightness indexes ranging from  $0.92\pm 0.025$  to  $0.94\pm 0.025$  ( $P>0.05$ ; Fig. 3. 15). The flight velocity and the altitude of upwind flights were also not influenced by different types of targets, with average velocities between  $1.42\pm 0.8$  and  $1.57\pm 0.7$   $\text{ms}^{-1}$  and average heights between  $0.35\pm 0.01$  and  $0.38\pm 0.15$  m ( $P>0.05$ ; Fig. 3. 15).



**Fig. 3.15.** Mean  $\pm$  SEM of straightness indexes, velocities and heights of upwind flights made by *G. pallidipes* over 1 m in the wind tunnel in the presence of the blue square and blue squares incorporating black 3D landing stimulus or a black 2D stripe at their bases. No effect of these treatments was recorded on the flight made by *G.*

*pallidipes* (ANOVA followed by a Tukey HSD test,  $P>0.05$ ). Numbers beneath treatments are numbers of flights analysed.

*Flights around 2D visual targets by G. pallidipes incorporating a landing stimulus in the wind tunnel*

The proportion of *G. pallidipes* flights around the base of 2D targets incorporating a 3D landing stimulus was high at  $75.5\pm 6 - 87\pm 5\%$  compared to flight proportions around middle ( $8.5\pm 2 - 17\pm 2\%$ ) and upper parts ( $7\pm 2 - 16\pm 2\%$ ) of targets (GLM with Poisson errors,  $P<0.0001$ , Fig. 3.16). No difference was recorded in flight proportions for the middle and the upper part of the targets ( $P>0.05$ ).

The presence of black bars (round or triangular) at the base of the blue target decreased significantly the length of flights from  $7.1\pm 0.7$  m for the all-blue target to  $4.7\pm 0.35$  and  $4.9\pm 0.4$  m for the target with the round and the triangular black bars, respectively (GLM with Gamma errors,  $P<0.05$ ). This was due to significantly higher landing responses on the treatments incorporating a 3D landing stimulus at their bases (see below). No difference was recorded in length of flights around the blue target when the black stripe was present at the base, with a length of  $6.8\pm 0.5$  statistically the same compared to  $7.1\pm 0.7$  m for the blue target alone ( $P>0.05$ ; Fig. 3.16).

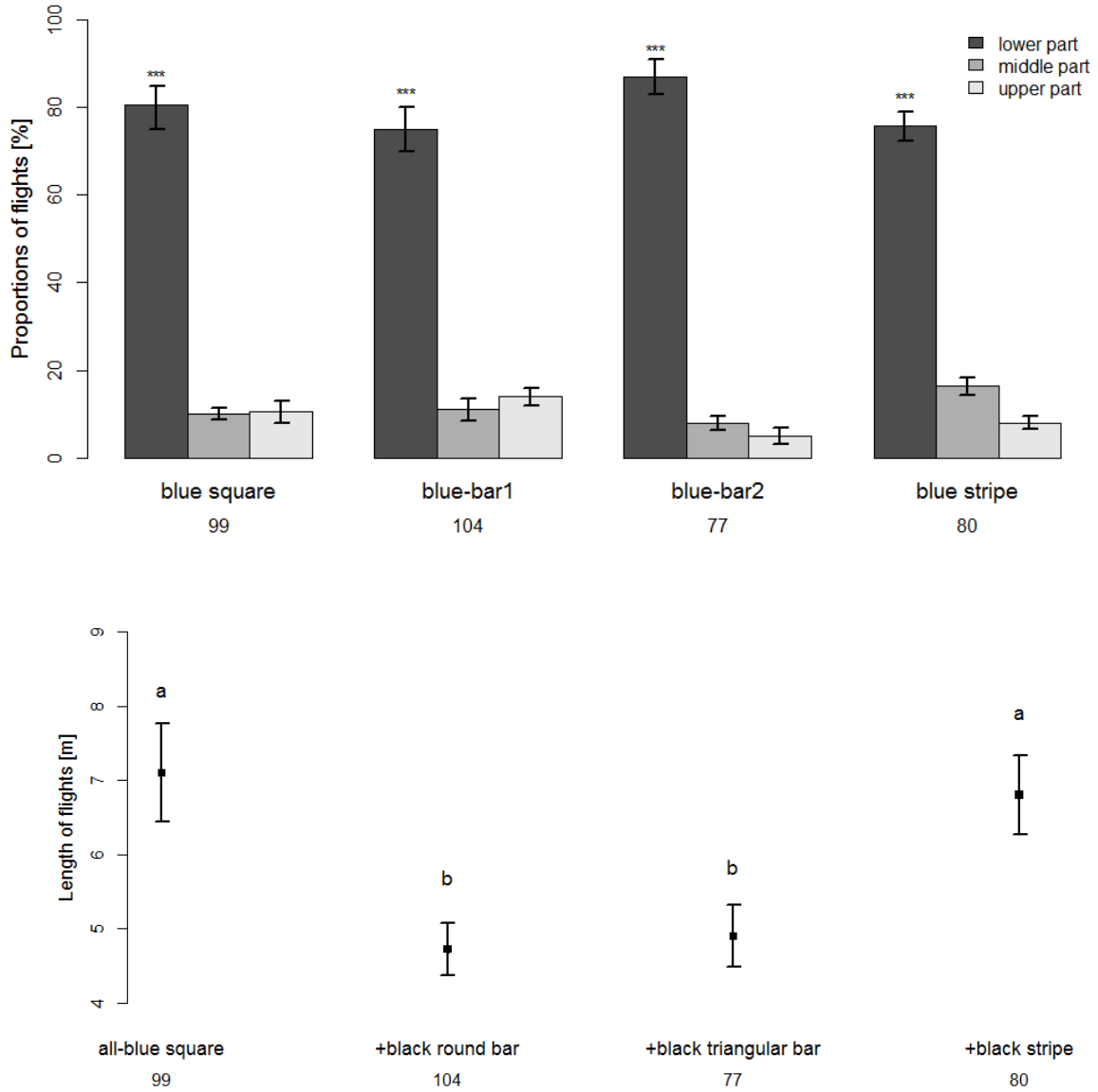

**Fig. 3.16. Top** Proportions (mean± SEM) of flights made by *G. pallidipes* around the blue square and blue squares incorporating a black 3D landing stimulus or a black 2D stripe at their bases in the wind tunnel; asterisks indicate significant differences between the lower and upper parts of flights made in the vicinity of the same object (GLM with Poisson errors,  $P < 0.0001$ ); **bottom** length (mean± SEM) of flights made by *G. pallidipes* in the vicinity of visual targets; values with same letters are not statically different (GLM with Gamma errors,  $P < 0.05$ ). Numbers beneath treatments are numbers of flights analysed.

*Landing and subsequent landing responses by *G. pallidipes* on blue targets incorporating a landing stimulus*

The proportion of landing flies was high at 65 and 60%, respectively, when a black round or triangular bar covered with a black cloth was joined to the lower border of the blue square compared to 30.5 and 36%, respectively, for the all-blue target and the one with the 2D black stripe (GLM with binomial errors,  $P < 0.005$ ; Fig. 3.17). The same pattern was observed for subsequent landing responses by *G. pallidipes*, with higher proportions at 65 and 59% of flies that landed at least twice, respectively, on the target with the black round and triangular bar compared to that on the all-blue target or on the blue target with the black stripe (GLM with binomial errors,  $P < 0.05$ ; Fig. 3.17). No difference in subsequent landings was found between the blue target and the target with the black stripe nor between targets with black round and triangular bars ( $P > 0.05$ , Fig. 3.17). Furthermore, the blue target with a blue bar at the base was tested ( $n = 47$ ). This target induced landing by 33% of *G. pallidipes* tested and subsequent landings account for 44% of total landings. These results were not different compared to those from the all-blue target ( $P > 0.05$ ).

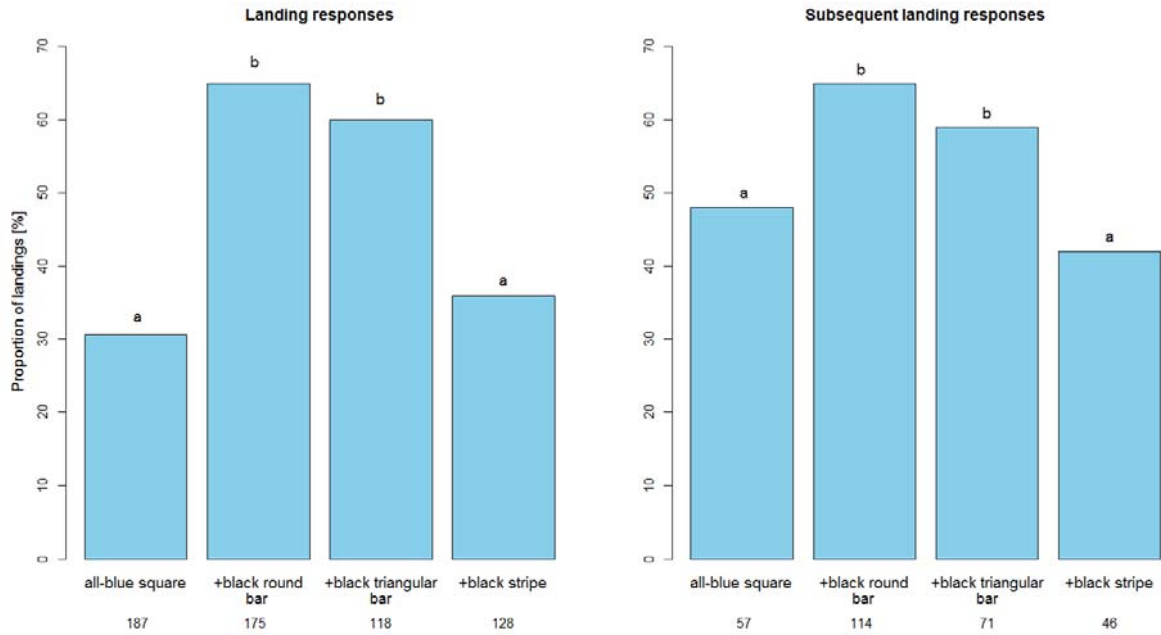
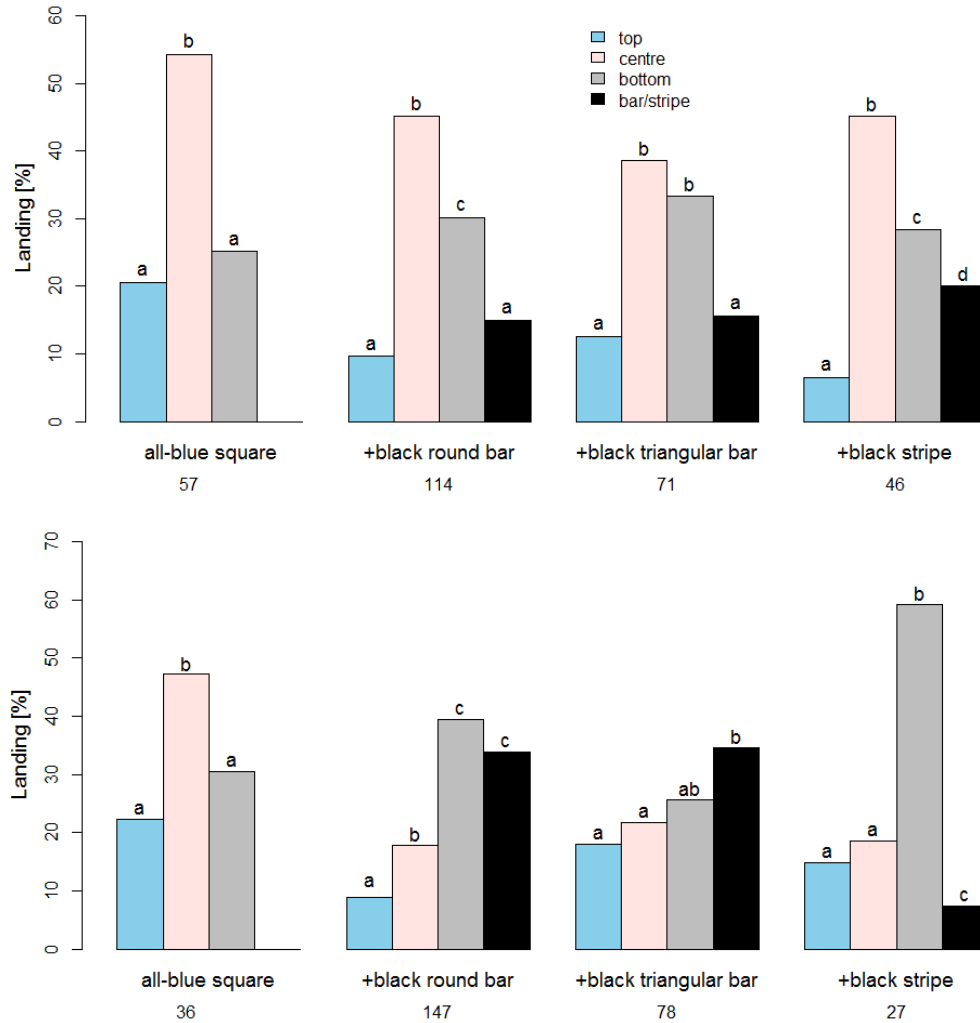

**Fig. 3.17.** Bar plots of Landing and subsequent landing responses by *G. pallidipes* on the blue square and blue squares incorporating a black 3D landing stimulus or a black 2D stripe at their bases in the wind tunnel. Bar plots with the same letters are not statistically different (GLM with binomial errors,  $P < 0.005$  and  $0.05$ , respectively, for landing and subsequent landing responses on targets). Numbers below treatments are total numbers of flies tested (left) and total numbers of landing flies (right).

*First and subsequent landing distributions by G. pallidipes on different parts of targets incorporating a landing stimulus*

In the following, the expression “landing on bars” refers to landings on the undersides of bars as 84 and 73% of landings occurred there for all-blue targets with a black round and triangular bar at the base, respectively. First landings by *G. pallidipes* were high at 54% on the centre of the all-blue target compared to 25 and 21%, respectively, for the bottom and the top (GLM with binomial errors,  $P < 0.005$ ; Fig. 3.18). In the presence of 2D black bars or black stripe on the all-blue target, first landings decreased significantly to 9-12.5% on the top in favour of the bottom plus the black bars (or black stripe) with 45-49% of landings ( $P < 0.05$ ; Fig. 3.18). This proportion was statically equal to landings in the centre (45%) of the target with the black round bar or black stripe ( $P > 0.05$ ), or superior to landings in the centre (38%) of the black triangular bar ( $P < 0.05$ ; Fig. 3.18). For the all-blue target, the preference for subsequent landing sites was similar to that for first landings, with higher landings on the centre (47%) compared to 31 and 22%, respectively, for the bottom and for the top (multinomial logistic regression,  $P < 0.05$ ; Fig. 3.18). When a black bar (round or triangular) was added, subsequent

landing sites in the centre decreased to 18 and 22%, respectively, in the presence of round and triangular bar ( $P < 0.005$ ). This decrease was in favour of the black bar where 35% of subsequent landings occurred (Fig. 3.18). In the presence of a black stripe, the proportion of subsequent landings was high on the bottom near the stripe at 59% compared to 18.5, 15, and 7.5%, respectively, on the centre, on the top and on the stripe ( $P < 0.005$ ).



**Fig. 3.18.** Distribution of first (**top**) and subsequent (**bottom**) landings by *G. pallidipes* in the wind tunnel on different parts of a 2D all-blue target compared to targets incorporating black (round or triangular) bars or stripe at the base. Proportions with different letters are statistically different for the same object with a probability level 0.05 following a GLM with binomial errors (top) or a multinomial logistic regression (bottom). Numbers below treatments are totals of first landings (top) and subsequent landings (bottom) on different parts of targets.

### 3.4. Discussion and conclusions

To date no successful attempts have been reported with tiny targets for controlling *Morsitans tsetse* whereas such targets provided satisfactory results against *Palpalis* group flies (Esterhuizen et al., 2011b, Tirados et al., 2015, Lindh et al., 2009). In order to extend the use of such cost-effective tools against *Morsitans tsetse* we investigated in the wind tunnel a possible improvement of blue tiny square targets for controlling *G. pallidipes* by incorporating to it a black 3D landing stimulus (round or triangular bar) at the base. This incorporation was based on (1) the propensity of *G. pallidipes* to alight on the bottom of a blue square target placed on the wall of a circular arena, (2) the fact that flies approach such a target from the below and (3) flies fly around the bottom of a visual object in the wind tunnel. No difference was observed in upwind flights to visual targets or in flights around visual targets by *G. pallidipes* in the wind tunnel. However, flies landed twice more on the all-blue target incorporating a black round or triangular bar at the base.

#### *Landing site preferences by G. pallidipes on 2D targets in an arena*

*G. pallidipes* landed mostly on the bottom of the blue triangle and the blue diamond whereas for the blue disk and the blue square, landings occurred both on the bottom and on the centre. The propensity of *G. pallidipes* to land on the centre of targets was reported by Vale (1993b). The latter found that for 2 m<sup>2</sup> horizontal oblong targets (all-blue, all black or blue-black vertically divided into blue and black parts) covered by electric grids, most *G. pallidipes* were invariably caught in the centre. Vale commented that even the vertical blue-black junction did not force flies away from the centre. However, Vale's observations (1993b) do not reveal the preferential landing height by *G. pallidipes* on targets. *G. austeni* landed on the bottom exterior edges of targets (Vreysen et al., 1998) and Oloo et al. (2014) found that more male *G. f. fuscipes* were caught on the bottom third of the blue and black portions of square 1 m<sup>2</sup> and oblong 1.5 m<sup>2</sup> all-blue and blue-black targets whereas females showed a preference for both the top and bottom sections. The preference for the bottom of the triangular target by *G. pallidipes* can also be explained by the fact that this part of the target is more extended. It was observed that increasing the width of targets or transforming them into horizontal oblongs increased landings by *G. pallidipes* and *G. m. morsitans* in the field (Vale, 1993b, Mramba et al., 2013). Landings on the bottom of the diamond could be explained by the ratio of the length of the bottom edge to the corresponding surface. The

perimeter: surface area ratio at the bottom (0.56) is greater than that in the centre (0.18) of the diamond. Doku and Brady (1989) found that landing by *G. m. morsitans* on black targets in the laboratory was influenced by the length of the target perimeter: the longer the edge the greater the landing response.

After several landings, resting sites of *G. pallidipes* on targets in the arena did not vary greatly compared to landing sites on targets. The same distributions were observed for the triangle, the disk and the square. On the diamond the number of flies resting on the centre was equivalent to that on the bottom. This suggests that preferential landing heights and resting sites on blue targets are generally the same *G. pallidipes*.

#### *Straightness, speed and height of G. pallidipes upwind flights in the presence of visual targets in the wind tunnel*

Blue, black and blue-black 2D targets were compared to a blue and a black sphere in the wind tunnel. The type of a visual target did not influence the straightness of *G. pallidipes* upwind flights with a straightness index of 0.83 when no visual target was present compared to 0.90 - 0.95 in the presence of a visual target. The upwind flight straightness of *G. brevipalpis* assessed in the same wind tunnel was measured at 0.84 and 0.97, respectively, to human breath alone and to human breath with a blue sphere upwind (Gurba et al., 2012). These findings are in agreement with those reported in the field where the straightness index of flights was more than 0.9 for *G. m. morsitans* and *G. pallidipes* to odour-baited visual targets (Gibson et al., 1991). In this study, the lower straightness in the absence of a visual target can be interpreted, as in the case of *G. brevipalpis*, as a strategy for sampling a large space to prevent odour loss (Gurba et al., 2012). However, the velocity in the absence of a target was the same compared to that recorded when any target was present, indicating that lower straightness (i.e. a more sinuous trajectory) did not decrease the speed of upwind flight in absence of a target in our wind tunnel conditions. It has been reported that the speed of *G. pallidipes* and *G. m. morsitans* in flight can exceed  $4 \text{ ms}^{-1}$  in the field (Torr, 1988a, Torr, 1988b, Gibson and Brady, 1988, Gibson and Brady, 1985) while in this study the average speed recorded was  $1.5 \text{ ms}^{-1}$  in the presence of visual targets. This lower speed is certainly due to constraints of flying in the wind tunnel. In the same wind tunnel where this study was conducted, the speed of *G. pallidipes* in the presence of a blue sphere was recorded at between  $1.25 - 1.6 \text{ ms}^{-1}$  (Chappuis, 2013). However, for *G. brevipalpis* speeds in the same

wind tunnel were 2.13 and 2.71 ms<sup>-1</sup> (range 0.6 – 4.6 ms<sup>-1</sup>), respectively, in the presence and absence of a blue sphere (Gurba et al., 2012), the fastest speeds reported for tsetse under such conditions. The altitude of *G. pallidipes* upwind flights was the same (0.36 – 0.38 m) in the presence of any visual target but was higher at 0.46 m when no target was present. In the same wind tunnel, *G. Brevipalpis* flew at 0.37 and 39 cm above the floor, respectively, in the presence and absence of the blue sphere (Gurba et al., 2012). These findings are in agreement with those reported in the field where the altitude of *G. pallidipes* and *G. m. morsitans* flights was about 0.3 m above the ground level (Bursell, 1984, Gibson and Brady, 1988, Torr, 1988a).

#### *Flights around visual targets in the wind tunnel*

Most flight trajectories occurred around the lower portion when flies were in the vicinity of visual targets, similar for all targets tested in this study. It has been reported that tsetse approach a visual device from the below (Vale, 1982, Flint, 1985) and once in the vicinity of such an object tsetse investigate it by circling (Gibson et al., 1991). Preference for flight by tsetse around the lower portion of targets in the wind tunnel can be explained by the fact that this area was most shadowed (luminosity measured throughout the wind tunnel was 300 ± 5 lux, but 225 ± 7 lux near the lower portion of 2D targets in the wind tunnel) as the source of illumination was above (see Materials and Methods). Scototaxis by tsetse for feeding and resting had been reported (see chapter 1; Bursell, 1961; Huyton & Brady, 1975). Flights below objects were also observed for blue, blue-black and black 2D targets in the field and were more pronounced for *G. pallidipes* than for *G. m. morsitans* (Vale, 1993b).

#### *Landing and subsequent landing responses by G. pallidipes on targets in the wind tunnel*

Some 73 and 50% of *G. pallidipes* tested landed, respectively, on the undersides of the blue and black spheres, higher compared to landings responses (25-35%) on all-blue or blue-black 2D targets. Few landings were recorded on black 2D targets compared to blue and blue-black ones and landing response on the black sphere was inferior to that on the blue one. Subsequent landings by the same flies followed the same pattern. Landings on 2D targets recorded here were lower than for observations made under field conditions where 40-50% of *G. pallidipes* landed on 2D targets (Vale and Hargrove, 1979). Evidently, the 3D shape of the spheres with the shadow created below them is the main landing-inducing factor for tsetse (Challier and Laveissière, 1973, Vale and Hargrove, 1979). It has been reported that *Morsitans*

group tsetse landed equally on blue and blue-black 2D targets in the field in the case of *G. pallidipes* (Vale, 1993b) and *G. swynnertoni* (Mramba et al., 2013). *G. pallidipes*, however, also landed equally on all-blue and all-black (1 m<sup>2</sup> square or 1 m x 2 m oblong) targets in the field (Vale, 1993b). Poor landing responses by *G. pallidipes* on all-black 2D targets recorded in the wind tunnel may be due to the size of the target used. Apparently, when the size of a black 2D target is reduced the attractiveness to *G. pallidipes* decreases, a factor that may have contributed to first landings by the flies on the blue portion of bicoloured 2D targets in this study. This also concords with observations in the field where black tiny targets were inefficient to induce landings by *G. pallidipes* (Torr et al., 2011).

#### *Efficiency of 2D tiny targets incorporating a landing stimulus in the wind tunnel*

Characteristics of upwind flights and flights around blue targets incorporating a landing stimulus were the same as those recorded in the presence of all-blue and blue-black 2D targets and with blue and black spheres. First and subsequent landings by *G. pallidipes* were double on the blue target incorporating a round or a triangular black bar at the base compared to those on the all-blue target. When bars were replaced by a black 2D stripe, landing responses decreased by a factor of 2, and became similar to that recorded on the all-blue target. Moreover, replacing the black round bar by a blue round one at the base of the blue target also decreased landings by *G. pallidipes* by a factor of 2. The presence of the black bar at the base of the blue target obviously contributes to an increase in landings by the flies. In the wind tunnel, first landings by *G. pallidipes* were mainly on the centre and on the bottom of the all-blue target as observed in the arena. Despite addition of a black landing stimulus at the base first landings were still recorded on the centre and on the bottom of the target. This supports the notion that *G. pallidipes* first lands on the blue portion as already recorded on blue-black 2D targets. However, the presence of the black bars or a black stripe at the base of the blue target influenced first and subsequent landing sites by decreasing landings on the upper parts of the target in favour of its bottom portion and on the bar or stripe. Apparently, when *G. pallidipes* is in its “host seeking” state the fly lands on targets and subsequently land on a 3D substrate corresponding to a resting site. When there is no such 3D substrate, flies subsequently land on the bottom near the interface between the blue portion and the black stripe. When a black 2D or 3D portion is absent at the base of the target subsequent landings are basically distributed in the same manner as first landings.

To summarize, blue tiny target incorporating a black 3D bar at the base shows promise as a cost-effective device to use for controlling *G. pallidipes*. Such a target should be efficient for other tsetse as the landing stimulus incorporated is a ubiquitous stimulus for tsetse, i.e. based on the shape of horizontal branches and twigs that are preferred as resting sites for all tsetse species. However, comparative studies must be performed in the field for the different tsetse species to fully investigate the efficacy of this new target. Such targets should be made of textiles permitting long-lasting retention of an insecticide like deltamethrin that is currently used for tsetse control. This practical application aspect is treated in the following chapter.



**4. The proportion of polyester in deltamethrin-impregnated visual targets affects their efficacy for controlling tsetse**

## Abstract

The use of deltamethrin-impregnated textiles remains an efficient method for the tsetse population control. Persistence of deltamethrin on textiles can be affected by weathering. In this chapter, laboratory and field studies were carried out to determine the best combination of cotton-polyester in textiles for long-lasting retention of deltamethrin for tsetse control. The effect of weathering on the capacity of four different deltamethrin-impregnated textiles, with increasing proportions (0, 35, 65 and 100%) of polyester, on their capacity to kill *G. pallidipes* after 45 s contact was assessed. Each textile sample was treated by saturation with an aqueous solution of deltamethrin at 1000 mg per m<sup>2</sup> of textile. Deltamethrin-treated textiles were weathered from February 2013 to August 2014 (18 months) in the Lambwe Valley (Kenya), where rainfall peaked at ca. 200 mm between April and May. After 9-months weathering, textiles made of 100% and 65% polyester were still able to kill 67% and 47% of laboratory-reared *G. pallidipes* 24 h after 45 s of contact. The remaining proportions of exposed flies were all knocked down. After 18-months weathering, only the 100% polyester textile was able to knock down all *G. pallidipes* exposed to it. Chemical analysis of fresh deltamethrin-treated but unweathered textiles showed that the quantity of deltamethrin picked up by the 100% polyester textile was 89 mg/m<sup>2</sup> or ca. 9% of the initial dose in water whereas this was only 61-69 mg/m<sup>2</sup>, i.e. 6-7% of the initial dose in water for the others textiles. After 9-months weathering the 100% and 65% polyester textiles still retained deltamethrin at 11 and 17 mg/m<sup>2</sup>, respectively, whereas only traces (<1 mg/m<sup>2</sup>) of deltamethrin were detected on the others textiles. The lethal dose of deltamethrin to kill 50% (LD<sub>50</sub>) of *G. pallidipes* was established at ca. 30 mg/m<sup>2</sup> on blotting paper. This values is two time higher than the 17 mg/m<sup>2</sup> deltamethrin retained on the 100% polyester textile that killed 67% of flies after 9 months of weathering. The use of such a deltamethrin-impregnated textile is discussed for better planning of campaigns for controlling tsetse populations.

**Keywords:** deltamethrin, polyester textiles, tsetse control.

#### 4.1. Introduction

Deltamethrin is a synthetic insecticide (second-generation) belonging to type II pyrethrinoids (with  $\alpha$ -cyano group) and works by blocking the ion channels in the opened state resulting in sustained depolarization and repeated nervous discharges causing paralysis (Clark and Brooks, 1989, Chalmers et al., 1987, Vijverberg and vanden Bercken, 1990). Deltamethrin has the advantage that it is biodegradable. The lethal dose ( $LD_{50}$ ) is between 0.45 - 1 mg/kg for insects by topical application and between 30 - 140 mg/kg in the rat when delivered orally (Kavlock et al., 1979, Chavasse and Yap, 1997). Deltamethrin is used in agriculture against pest insects under varying climatic conditions and is currently the most widely used insecticide for impregnating bed nets for long-term control of malaria (Lengeler, 2004). It is also used for impregnating traps and targets made of textile used as visual lures for tsetse (Dagnogo et al., 1986, Laveissière et al., 1985, Merot et al., 1984, Torr et al., 1992) and for treating cattle in tsetse population control campaigns (Thomson, 1987, Thompson et al., 1991, Vale et al., 1999). Doses of deltamethrin used for these operations (2-200mg/m<sup>2</sup>) are not toxic to humans (Barlow et al., 2001). Further advantages are its efficacy against others ectoparasites (*Culex spp.* mosquitoes, bedbugs, lice and ticks) and persistence on bed nets against mosquitoes (Gimnig et al., 2005). The persistence of deltamethrin on cotton cloth treated with 0.6% deltamethrin suspension for the control of tsetse populations is about twelve months (Torr et al., 1992). Resistance to deltamethrin in tsetse has never been reported. Tsetse treated within two days post-feeding with deltamethrin show a high level of tolerance to the insecticide but this decreases with increasing starvation: a strong correlation has been recorded between tsetse fat body levels and mortality due to deltamethrin, with mortality decreasing when fat levels are high (De Deken et al., 1998).

It has been estimated that insecticide-treated and odour-baited visual traps or targets deployed at a density of just four devices/km<sup>2</sup> is sufficient to eliminate populations of the *morsitans* group tsetse (Vale et al., 1988, Knols et al., 1993, Willemsse, 1991) whereas for the *palpalis* group higher densities of 15-30 devices/km<sup>2</sup> are required (Challier and Laveissière, 1973, Merot et al., 1984, Vale et al., 2015). However, such devices need to be resprayed at 2-3 month intervals with deltamethrin to maintain their efficacy (Vale et al., 1988). Other studies have investigated the persistence of deltamethrin on cotton cloth to show that the efficiency of visual targets to kill tsetse is reduced during the wet season (Torr, 1985; Laveissière et al.,

1985). Torr et al. (1992) found that for controlling *G. pallidipes* populations in Southern Africa, cotton cloth targets (290g/m<sup>2</sup>) sprayed with a 0.1% deltamethrin suspension can be effective for 4-10 months. It is known that deltamethrin is better retained on fabrics made of polyester (Gimnig et al., 2005) and the WHO has recommended mosquito netting made of polyester for campaigns against mosquito vectors of malaria because of the persistence of deltamethrin on polyester over successive washings (WHO, 2013). In the present work the effect of weathering on the capacity of four different deltamethrin-impregnated textiles, with increasing amounts of polyester, on their capacity to kill *G. pallidipes* over time was tested. For this, knock down (KD) tests were performed at 3-month intervals on tsetse using textiles weathered in Kenya from 3 to 18 months. In addition, the residual dose of deltamethrin on 9-month weathered textiles was determined to compare their toxicity to the LD<sub>50</sub> determined on blotting paper with a view to better planning of control campaigns using textiles-based visual targets.

## 4.2. Materials and methods

### *Insects*

*G. pallidipes* pupae were obtained from the International Atomic Energy Agency (IAEA, Vienna). Imagos were maintained in rectangular cotton netting cages (25cm × 15cm × 15cm, 1 mm mesh), in a climate chamber (described in Chapter 2) at 25°C, 80% relative humidity (RH). Flies were fed on day 2 with heparinized (1000 units/ml) bovine blood through a silicone membrane (Langley and Maly, 1969) at 37°C. Knock down (KD) tests were performed 24 h later with female flies.

### *Textiles, insecticide and weathering*

Four different textiles were tested:

- C180 Azur 623 phthalogen blue (**TDV\_C180**) 100% cotton, 180 g/m<sup>2</sup>; TDV Industries, Laval, France;
- S250 Azur 623 phthalogen blue (**TDV\_S250**) 65% cotton/35% polyester, 250 g/m<sup>2</sup>; TDV industries, Laval, France;
- Turquoise blue Q10067 (**SFG\_Tq**) 35% viscose/65% polyester, 234 g/m<sup>2</sup>; Sunflag, Nairobi, Kenya;
- Black fabric Q15093 (**SFG\_Bk**) 100% polyester, 225 g/m<sup>2</sup>; Sunflag, Nairobi, Kenya.

For reasons of clarity names of textiles are accompanied by their corresponding proportions of polyester in brackets as follow: TDV\_C180 (0), TDV\_S250 (35), SFG\_Tq (65) and SFG\_Bk (100).

Textiles were treated with an aqueous solution containing 1000 mg of deltamethrin per m<sup>2</sup> of textile using a Glossinex 20% w/v suspension concentrate (Coopers, Zimbabwe), a commercially available water-dilutable formulation. The volume of the solution used for treating a given type of textile was just sufficient to fully saturate 1 m<sup>2</sup> of the textile. Textile samples were then left to dry. A piece of TDV\_C180 (0) treated with water under the same conditions served as control. Textiles samples were exposed in the Lambwe Valley (1°17'29.45'' S, 36°52'27.34'' E; altitude of 1628 m) in Kenya from february 2013 (month 0) to august 2014 (month 18) and pieces were collected every 3 months (Photo 4.1), sealed in

aluminium envelopes and sent to the laboratory of Animal Physiology, University of Neuchâtel, Switzerland for tests.

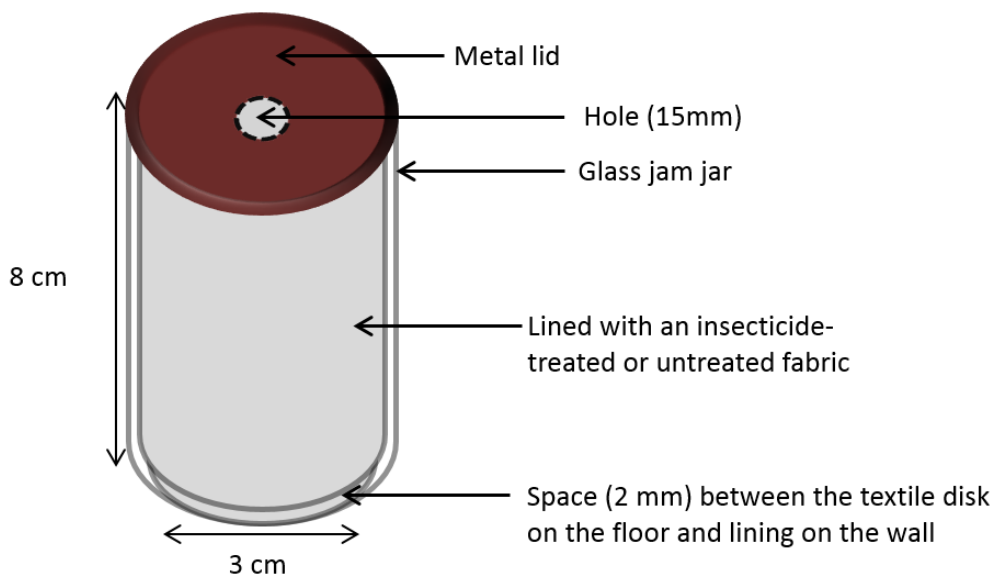

**Photo 4.1.** Deltamethrin-impregnated textiles (1 m x 2 m) after 3 months of weathering in the Lambwe Valley in Kenya and **sampled** twice (no weathering and after 3 months of weathering).

#### *Assessment of the toxicity of weathered deltamethrin-impregnated textiles against *G. pallidipes* in the laboratory*

The lethal effects of deltamethrin-impregnated weathered fabrics on *G. pallidipes* was assessed using glass jam jars as KD chambers (Fig. 4.1). Using disposable gloves, pieces of the deltamethrin-impregnated textiles were cut into rectangles (15.5 cm x 8 cm) and disks (3 cm diameter) to line, respectively, the inner walls and bottoms of the glass jars whose lids had a hole (15 mm diameter) to allow the introduction of flies. A small space (about 2 mm) was left between the disk on the floor and the cloth lining the wall of the glass jar to attract flies towards the light when the jar was upturned (Fig. 4.1). For KD tests, flies were introduced into the jar, the hole in the lid was stopped with cotton wool and the jar was upturned for 45 sec. Flies were then released into a cotton netting cage (1 mm mesh, 25cm x 15cm x 15cm) for observation of the effects of treatments. Tsetse were considered knocked down when they were not able to fly or to stand upright on either the walls or on the bottom of the cage but were still able to move their legs; they were considered dead if no movement was observed. Three repetitions of 4-5 flies per jar were made per sample of deltamethrin-impregnated

weathered fabrics and for the untreated control. Numbers of knocked down and dead flies were recorded after 15 min, 1 h, 3 h and 24 h.



**Fig. 4.1.** Knock down chamber made of a glass jam jar lined with deltamethrin-impregnated test fabrics.

#### *Determination of deltamethrin residues on 9-month weathered fabrics*

The amount of deltamethrin retained on 9-month weathered textile samples was compared to that of freshly impregnated samples. Chemical analysis for the determination residue was made by Dr Armelle Vallat, Neuchâtel Platform of Analytical Chemistry (Faculty of Science, University of Neuchâtel) and the protocol for extraction of deltamethrin from textiles was adapted following Zhou et al. (2007). For this, 50 cm<sup>2</sup> of textile was cut into 32 pieces and put into a 50 mL Erlenmeyer flask using disposables gloves. Half a ml of a solution of cypermethrin at 1mg/ml in hexane-ethyl acetate (1:1, v/v) was added to the textile pieces as internal standard and left to dry. Then 10 mL hexane-ethyl acetate (1:1, v/v) was added to the Erlenmeyer flask and the content was subjected to ultrasonication for 20 min. The textile extract was filtered through a 0.22 µm, 13 mm PTFE syringe filter (BGB Analytik SA). All textile samples (100% cotton; 35%, 65% and 100% polyester) including the untreated control sample were extracted using the same protocol. Ethyl acetate (LC-MS Chromasolv® grade), hexane (HPLC grade, ≥ 97%) and cypermethrin were purchased from Sigma-Aldrich (Buchs, Switzerland).

Determination of the deltamethrin content of extracts was made with a 7890B Gas Chromatograph (GC) equipped with a 5977A MSD mass spectrometer (Agilent Technologies, Santa Clara, CA, USA) fitted with a 30 m x 0.25 mm Rxi®-5MS capillary column (0.25 µm film thickness; Restek, France). 1 µL of extracts was injected in splitless mode at 270°C and helium was used as carrier gas at 1 mL/min. The column temperature was 120°C for 5 min, then heated to 280°C at 20°C /min and held at 280°C for 20 min for a total runtime of 33 min. The mass spectrometer operated in electron ionization (EI) mode at 2.9 scans/s covering a mass-to-charge ( $m/z$ ) range 40 to 550. The amount of deltamethrin in the textile sample was normalized to the internal standard and is reported in mg/m<sup>2</sup> of textile. Two samples of each textile were analysed.

#### *Determination of the LD<sub>50</sub> of deltamethrin for laboratory reared G. pallidipes*

To provide a gauge of the effective dose of deltamethrin necessary to kill *G. pallidipes* complementary KD tests were performed with different doses of the insecticide using blotting paper (275 g/m<sup>2</sup>) and jam jars as described for the textile samples above (Fig. 4.1). Blotting paper pieces were treated with 20, 50, 100, and 200 mg/m<sup>2</sup> of deltamethrin and left to dry for 24 h in a fume hood before KD tests that were made as described above for the weathered fabrics; blotting paper treated with water served as control. Three repetitions with 8-11 flies were made per dose of deltamethrin. Numbers of dead flies were recorded after 24 hours.

#### *Data analysis*

The Chi square test with contingency table was used to compare mortalities induced by weathered textile samples. Mortality was plotted as a function of the deltamethrin concentration on blotting paper and a linear regression was fitted to determine the LD<sub>50</sub> for deltamethrin at 24 h using R software (version 3.1.3). The same software was used to generate all other figures presented.

### 4.3. Results

#### *Effect of weathering on the efficacy of deltamethrin-impregnated textiles*

Mortalities at 24 h after exposure of *G. pallidipes* for 45 s to weathered fabrics dropped from 100% at month 0 to less than 50% in the third month for TDV\_C180 (0) and TDV\_S250 (35) (Fig. 4.2a). Mortality decreased progressively until month 15 for SFG\_Tq (65) and its capacity to kill more than 50% of flies ceased at month 9. SFG\_Bk (100) continued to kill 50% of flies after 9 months and then dropped progressively. Declines in mortality were reciprocated by increasing numbers of knocked down flies (Fig. 4.2a). In the case of SFG\_Tq (65) for example, the gradual decline in mortality associated with weathering over time was matched by a progressive increase in the proportion of knocked down tsetse meaning that flies that survived were at least knocked down (Fig. 4.2b). 9 to 12-month weathered TDV\_S250 (35), SFG\_Tq (65) and SFG\_Bk (100) knocked down more than 90% of *G. pallidipes* 1 h after exposure (Table 4.1) whereas 15 and 18-month weathered SFG\_Bk (100) textile samples were still able to knock down more than 50% of *G. pallidipes* 30 min after exposure (Table 4.1). Furthermore, all flies that were exposed to 18-month weathered SFG\_Bk (100) textile samples were knocked down at 24 h whereas no KD was observed for flies exposed to the other 18-month weathered fabrics.

Analysing the cumulative number of dead flies calculated for each textile type over the 18 months of weathering revealed no statistical difference between the cumulative number of dead flies for SFG\_Bk (100) and SFG\_Tq (65) ( $\chi^2 = 2.6$ ,  $P > 0.05$ ; Table 3.2); SFG\_Bk (100) killed significantly more flies than TDV\_C180 (0) ( $\chi^2 = 20.7$ ,  $P < 0.0001$ ) and TDV\_S250 (35) ( $\chi^2 = 10.6$ ,  $P < 0.001$ ; Table 3.2). SFG\_Tq (65) killed significantly more flies than TDV\_C180 (0) ( $P = 0.0045$ ,  $\chi^2 = 8$ ) and there was no statistical difference between the number of flies killed by TDV\_S250 (65) and by SFG\_Tq (35) ( $p = 0.09$ ,  $\chi^2 = 2.74$ ) over 18 months. Likewise, no statistical difference was observed between the number of flies killed by TDV\_180 (0) and by TDV\_S250 (35) ( $p = 0.2$ ,  $\chi^2 = 1.4$ ).

Recordings of rainfall during the period of weathering shows that the rainy season lasted about 3 months (March to May) when peak in rainfall was recorded at between 185 - 190 mm (Fig. 4.2c). The remaining period corresponded to the dry season when rains were less frequent with rainfall levels between 20 – 60 mm.

The proportion of polyester in deltamethrin-impregnated visual targets affects their efficacy for controlling tsetse

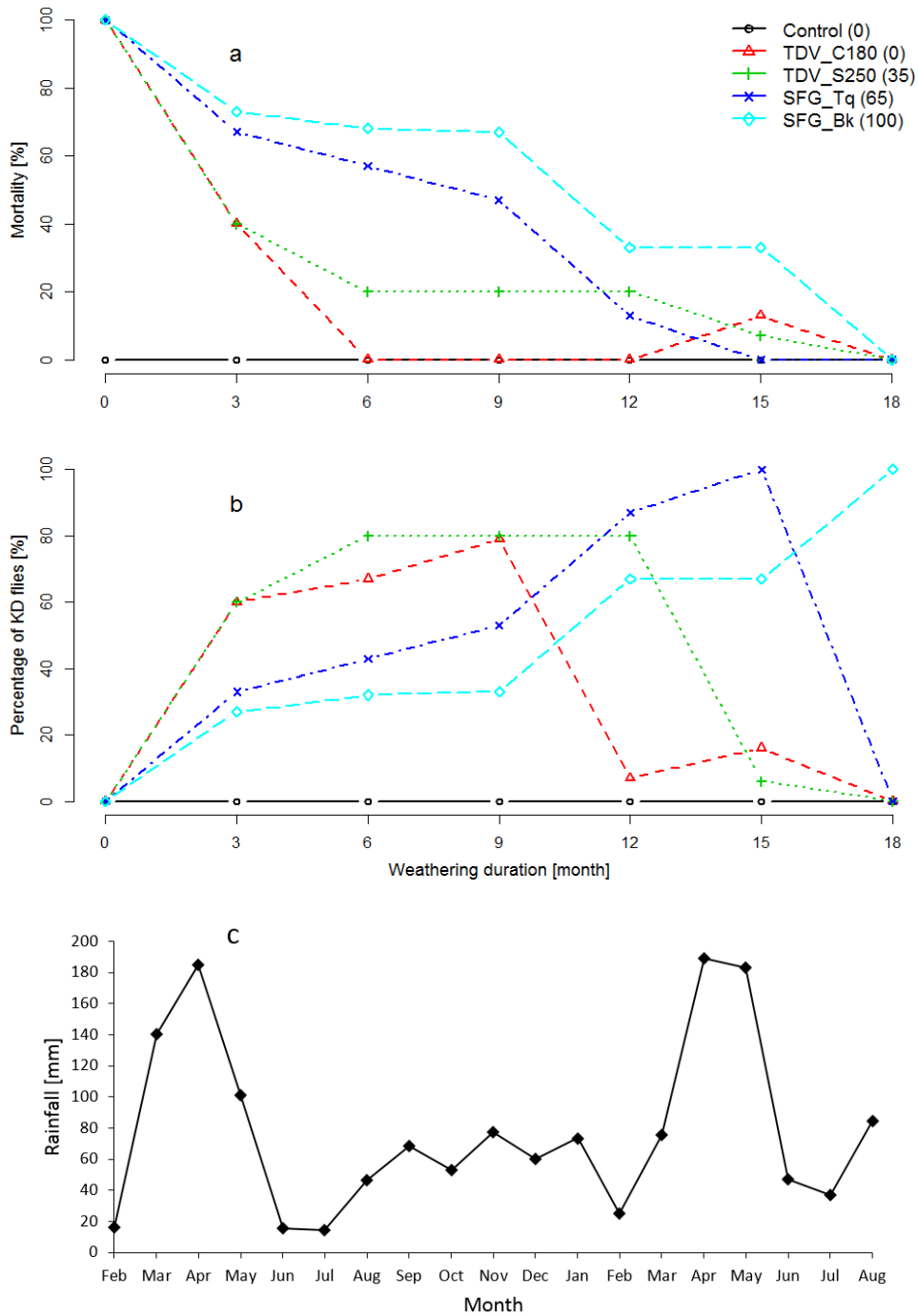

**Fig. 4.2.** Proportions of dead (a) and knocked down (b) *G. pallidipes* following exposure to textile samples weathered in the field for between 3 and 18 months (numbers in parentheses in the legends are proportions of polyester in the textiles); (c) Rainfall recorded over the period of weathering from February 2013 to August 2014 at the exposition site (Lambwe Valley, Kenya).

**Table 4.1. Results of knock down tests performed over 18 month with weathered textiles using laboratory reared *G. pallidipes***

Exposure time: 45 s			15 min			30 min			60 min			120 min			24 h		
textiles	month	Nb flies	al%	kd+d %	d%	al%	kd+d %	d%	al%	kd+d %	d%	al%	kd+d %	d%	al%	kd+d %	d%
Control (0)	0	15	100	0	0	100	0	0	100	0	0	100	0	0	100	0	0
	3	15	100	0	0	100	0	0	100	0	0	100	0	0	100	0	0
	6	14	100	0	0	100	0	0	100	0	0	100	0	0	100	0	0
	9	15	100	0	0	100	0	0	100	0	0	100	0	0	100	0	0
	12	15	100	0	0	100	0	0	100	0	0	100	0	0	100	0	0
	15	14	100	0	0	100	0	0	100	0	0	100	0	0	100	0	0
	18	15	100	0	0	100	0	0	100	0	0	100	0	0	100	0	0
TDV C180 (0)	0	15	0	100	0	0	100	33	0	100	66	0	100	93	0	100	100
	3	15	0	100	0	0	100	0	0	100	0	0	100	0	0	100	40
	6	15	100	0	0	100	0	0	40	<b>60</b>	0	27	73	0	33	67	0
	9	15	100	0	0	93	7	0	47	<b>53</b>	0	13	87	0	21	79	0
	12	15	100	0	0	93	7	0	93	7	0	53	47	0	93	7	0
	15	15	100	0	0	100	0	0	100	0	0	100	0	0	71	29	13
	18	15	100	0	0	100	0	0	100	0	0	100	0	0	100	0	0
TDV S250 (35)	0	15	0	100	0	0	100	21	0	100	64	0	100	64	0	100	100
	3	15	0	100	0	0	100	0	0	100	0	0	100	0	0	100	40
	6	15	100	0	0	60	40	0	0	100	0	0	100	20	0	100	20
	9	15	100	0	0	93	7	0	0	<b>100</b>	0	0	100	20	0	100	20
	12	14	100	0	0	87	13	0	7	<b>93</b>	0	0	100	0	0	100	20
	15	15	100	0	0	100	0	0	100	0	0	100	0	0	87	13	7
	18	14	100	0	0	100	0	0	100	0	0	100	0	0	100	0	0
SFG Tq (65)	0	15	0	100	0	0	100	8	0	100	54	0	100	69	0	100	100
	3	15	0	100	0	0	100	0	0	100	0	0	100	0	0	100	67
	6	14	50	50	0	0	100	0	0	100	21	0	100	21	0	100	57
	9	15	100	0	0	7	93	0	0	100	0	0	100	47	0	100	47
	12	15	93	7	0	67	33	0	0	<b>100</b>	0	0	100	0	0	100	13
	15	14	100	0	0	71	29	0	7	<b>93</b>	0	0	100	0	0	100	0
	18	14	100	0	0	100	0	0	94	6	0	87	13	0	100	0	0
SFG Bk (100)	0	15	0	100	0	0	100	0	0	100	60	0	100	73	0	100	100
	3	15	0	100	0	0	100	0	0	100	0	0	100	0	0	100	73
	6	15	93	7	0	0	100	0	0	100	0	0	100	0	0	100	<b>68</b>
	9	15	67	33	0	0	100	0	0	100	0	0	100	0	0	100	<b>67</b>
	12	15	67	33	0	0	100	0	0	<b>100</b>	0	0	100	0	0	100	33
	15	15	87	13	0	40	<b>60</b>	0	7	<b>93</b>	0	0	100	0	0	100	33
	18	15	100	0	0	47	<b>53</b>	0	7	<b>93</b>	0	0	100	0	0	100	0

**Nb flies** = number of flies tested, **al%** = proportion of flies alive, **kd+d%** = pooled proportion of knocked down and dead flies, **d%** = proportion of dead flies. Numbers in brackets are proportions of polyester in the weathered textiles.

**Table 4.2. Statistical comparisons of the cumulative number of dead *G. pallidipes* recorded after 45 s contact with textile samples exposed in the field for between 3 and 18 months**

textiles	Total <sup>a</sup>	Dead flies <sup>b</sup>	$\chi^2$ value <sup>c</sup>	P value <sup>c</sup> (95%)
TDV_C180 (0)	105	23	20.7	< 0.0001
TDV_S250 (35)	103	31	10.6	< 0.001
SFG_Tq (65)	102	42	2.6	= 0.1
SFG_Bk (100)	105	56	-	-

(a) Cumulative number of flies exposed to the textile samples weathered for 3, 6, 9, 12, 15 and 18 months; (b) Cumulative number of dead flies recorded every 3 months over 18 months of KD tests; (c) Statistical comparisons of mortality on each textile sample presented on this table were made relative to SFG\_Bk.

#### *Determination of the amount of deltamethrin in the weathered fabrics*

The amount of deltamethrin on freshly impregnated textiles was 61, 67, 69.5 and 88.5 mg/m<sup>2</sup>, respectively, for TDV\_180 (0), TDV\_S250 (35), SFG\_Tq (65) and SFG\_Bk (100), i.e. 6-9% of the initial concentration in water was taken up (Fig. 4.3). After 9 months of weathering, deltamethrin had almost disappeared from TDV-180 (0) and TDV\_S250 (35) whereas the residual levels on SFG\_Tq (65) and SFG\_Bk (100) were 11 and 17 mg/m<sup>2</sup>, respectively, i.e. 16 and 18% of the initial impregnation levels (Fig. 4.3).

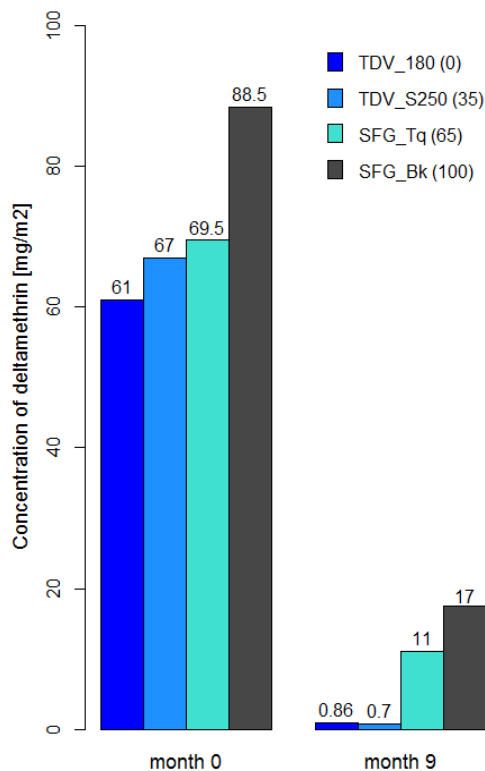
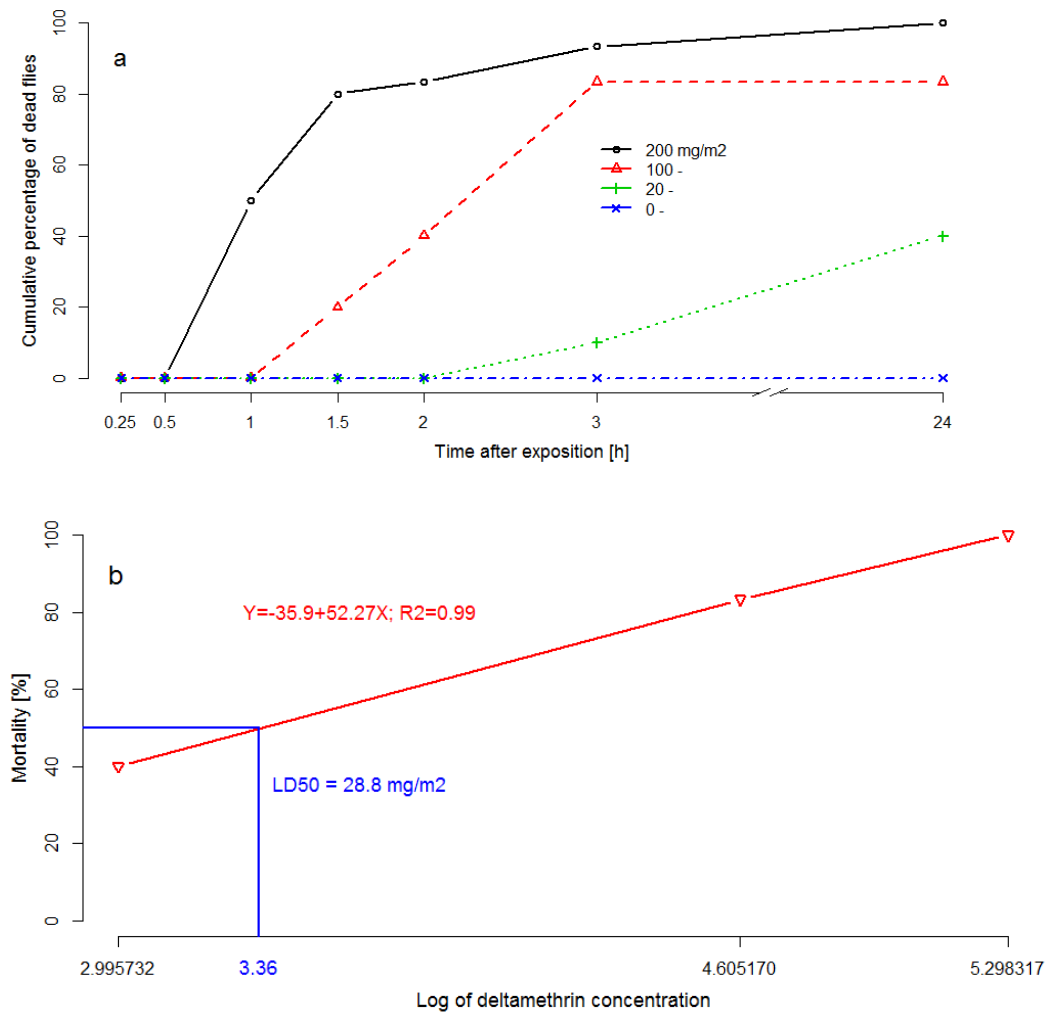

**Fig. 4.3.** Amount of deltamethrin on freshly impregnated (no weathering) and 9-month weathered textiles determined by GC-MS (numbers in parentheses on legends are the proportions of polyester in textiles). Textiles were impregnated with deltamethrin in an aqueous solutions at 1000 mg/m<sup>2</sup> that saturated the square meter of the textile sample.

#### *Determination of the LD<sub>50</sub> for deltamethrin on blotting paper*

Mortality appeared 30 min after exposure of *G. pallidipes* to 200 mg/m<sup>2</sup> deltamethrin-impregnated blotting paper, around 50% of flies had died 1 h after exposure and this increased to 80% after 1.5 h (Fig. 4.4a). No mortality was observed 1 h after exposure to the dose of 100 mg/m<sup>2</sup> but mortality increased to 80% after 3 h. For the lowest dose of 20 mg/m<sup>2</sup> mortality reached 40% at 24 h after exposure (Fig. 4.4a). Plotting mortality as a function of the logarithm of deltamethrin dose shows that at 24 h after exposure of flies mortality increased linearly following the equation  $Y = -35.911 + 52.276X$  ( $R^2 = 0.99$ ; Fig. 4.4b). This regression indicates a LD<sub>50</sub> for deltamethrin at 24 h on the blotting paper at **28.8 mg/m<sup>2</sup>** for *G. pallidipes* (Fig. 4.4b).

The proportion of polyester in deltamethrin-impregnated visual targets affects their efficacy for controlling tsetse



**Fig. 4.4. (a)** Cumulative mortality of *G. pallidipes* over time following exposure to different doses of deltamethrin on blotting paper; **(b)** Mortality of *G. pallidipes* as a function of the logarithm of the dose of deltamethrin on the blotting paper. The formula for the linear regression describing mortality and the value of the LD<sub>50</sub> are presented on the graph.

#### 4.4. Discussion and conclusions

The capacity of deltamethrin-impregnated textiles to retain the insecticide was influenced by the proportion of polyester that they contained. Samples from deltamethrin-impregnated and weathered SFG\_Tq (65) and SFG\_Bk (100) showed equivalent levels of toxicity against *G. pallidipes* in that they could still kill *ca.* 50% of flies exposed to them after 9 months of weathering. 9-month weathered TDV\_C180 (0) and TDV\_S250 (35) killed, respectively, 0 and 20% of flies 24 h after exposure but were still able to knock down > 50% of flies. Recording the rainfall showed that the first three months of weathering corresponded to the rainy season where the toxicity of TDV\_C180 (0) and TDV\_S250 (35) against *G. pallidipes* rapidly declined by 60% whereas toxicity of SFG\_Tq (65) and SFG\_Bk (100) declined only by 33 and 27%, respectively. Chemical analyses showed that 6-9% of deltamethrin was picked up during textile impregnation. The amount of deltamethrin initially picked up in water was equivalent (61 – 69 mg/m<sup>2</sup>) for TDV\_C180 (0), TDV\_S250 (35) and SFG\_Tq (65) but higher at *ca.* 89 mg/m<sup>2</sup> for SFG\_Bk (100). After 9-months weathering 16 and 18% of the amounts initially picked up in water were detected on SFG\_Tq (65) and SFG\_Bk (100), respectively, whereas only insecticide traces (<1 mg/m<sup>2</sup>) were detected on TDV\_C180 (0) and TDV\_S250 (35). This permits us to conclude that polyester retains deltamethrin better than cotton. The textiles used in this study were not of the same weight. As an example, the SFG\_Bk (100) with the higher toxicity against *G. pallidipes* had a weight of 225 g/m<sup>2</sup> compared to that of TDV\_S250 (35) at 250 g/m<sup>2</sup> that was less toxic as an insecticide-impregnated fabric to flies after 9 months of weathering. Furthermore, toxicity against *G. pallidipes* of TDV\_C180 (0) with a weight at 180 g/m<sup>2</sup> was equivalent to that of TDV\_S250 (35) with a weight of 250 g/m<sup>2</sup> over 18 months, indicating that the deltamethrin retaining power of the weathered textiles was not influenced by the weight of textiles but was polyester-proportion dependent. Evidently, the decrease of weathered textile toxicity against *G. pallidipes* over time was due to the decrease in the amount of remaining insecticide after weathering (Spurlock and Lee, 2008). One could criticize the test protocol for the KD test as it was done with only one sample from each weathered textile at three-month intervals. Nevertheless, the decline in the toxicity of insecticide-impregnated textiles with time is obvious (Fig. 4.2) leaving no doubt regarding the validity of the tests.

The once off saturation of the textile samples used in this study may not have allowed an optimal impregnation with deltamethrin compared to treatment by immersion. Mangwiro et al. (1999a), for example, have estimated that the initial dose of deltamethrin after immersion of black cotton cloth (290 g/m<sup>2</sup>) in a 0.1% aqueous solution of the active ingredient was 500 mg/m<sup>2</sup>. With a formulation at 0.6% deltamethrin, retention was superior to 1000 mg/m<sup>2</sup> on a black drill cotton cloth (290 g/m<sup>2</sup>) treated by immersion and the textile killed more than 90% of *G. pallidipes* after 10 months of weathering (Torr et al., 1992). Here we show that an initial amount of deltamethrin at 88 mg/m<sup>2</sup> on SFG\_Bk (100) can still kill 50% of *G. pallidipes* after 9 months of weathering. Moreover, 15-month weathered SFG\_Bk (100) can knock down >90% of flies 60 min after exposure. The initial amount detected on SFG\_Bk (100) reported here corresponds to that on black cotton cloth when treated by immersion in a 0.03% aqueous solution of deltamethrin (Torr et al., 1992). However, we would not have obtained the same results if the textiles had been weathered in an area of heavy rainfall. We recorded peaks of rainfall between 180 – 200 mm over the period of weathering, less than the 550 – 750 mm reported by Torr et al. (1992) in the Zambezi Valley (Zimbabwe).

A dose of deltamethrin at 20 mg/m<sup>2</sup> on blotting paper caused mortality in 40% of *G. pallidipes* 24 h after exposure. The estimated LD<sub>50</sub> for deltamethrin was at 29 mg/m<sup>2</sup> (rounded up at 30 mg/m<sup>2</sup>) and analysis of 9-month weathered SFG\_Bk (100) that still killed 67% of *G. pallidipes* showed that the textile retained 17 mg/m<sup>2</sup> of deltamethrin. This suggests that the deltamethrin is twice more available to tsetse on SFG\_Bk (100) than on blotting paper. No data is available for the LD<sub>50</sub> on visual targets used for tsetse control. However, the high sensitivity of tsetse to deltamethrin has already been documented. When deltamethrin is topically applied to the dorsal thorax of flies the LD<sub>50</sub> is in the range of 0.03 – 3 ng/tsetse depending on the species, nutritional status and temperature (Van Den Bossche, 1996, De Deken et al., 1998). The LD<sub>50</sub> for deltamethrin is at > 3 ng/tsetse for pregnant flies (De Deken et al., 1998) is certainly due to the diffusion of the insecticide into the lipid-rich larval food during pregnancy (Riordan, 1987, Burnett, 1961).

In conclusion, deltamethrin-treated and weathered textiles made of 100% polyester showed a sufficient toxicity for controlling *G. pallidipes* over 18 months from a small initial dose of the insecticide adsorbed per square meter. This suggests the possibility of reducing the formulation of deltamethrin to 0.1% in water for treating tsetse visual targets by

immersion resulting in an initial concentration of ca. 250 mg/m<sup>2</sup> on polyester textile used in this study. Such a formulation used to treat visual targets made of polyester would lead to a cost-effective method for tsetse population control over more than twelve months in the field without having to respray the targets with insecticide. We showed that even a dose of ca. 1 mg/m<sup>2</sup> on textiles can knock down more than 50% of *G. pallidipes* and knocked down tsetse are rapidly eliminated by predators in the field (Laveissière et al., 1985). Furthermore, when the visual target treated with deltamethrin is sufficiently efficient to induce flies to land, a delay of 9 months is probably adequate for reducing even high initial densities of tsetse (Vale et al., 1988).



## **5. General discussion and research perspectives**



## 5. General discussion and research perspectives

Improvement of devices over decades for tsetse population control was based first on the interest of tsetse to approach a visual object from below, the principle for the first trap (3D object) developed against tsetse (Harris, 1930). It was then found that black surfaces elicit landing responses of tsetse (Laveissière et al., 1987; Green, 1988; Vale, 1993). Subsequently, studies on variations in shapes of 2D visual targets have shown that increasing in width of such targets enhances their attractiveness to tsetse (Vale, 1993; Vreysen et al., 1998). Furthermore, contrast between blue and black colours has been found efficient to induce landing on visual targets by tsetse (Green, 1989). For this study we hypothesized that when an object meets all the above features, an approaching tsetse would irresistibly land on it. Cost-effective devices for tsetse control have been developed, consisting of 0.25 m x 0.25 m tiny insecticide-impregnated 2D targets that, unfortunately, work only for riverine tsetse species (Hargrove, 1980; Vale, 1993; Torr et al., 2011). Efforts remain to be made for cost-effective visual baits against savannah tsetse and *G. pallidipes*, which belongs to this tsetse group, has been used here in an attempt to improve visual baits through laboratory studies.

Tsetse are considered as diurnal insects that spend most of their time resting. In order to establish tsetse resting locations with a view to target insecticide use against them, resting site preferences of tsetse have been extensively studied (Nash, 1952, Okiwelu, 1982, Okiwelu, 1983, Okiwelu, 1977, Pilson and Leggate, 1962, Okoth and Kapaata, 1987, Abdurrahim, 1971, Swynnerton, 1936, Harley, 1954). Resting sites of tsetse therefore become important to study their fundamental survival behaviours. I firstly provide in this thesis evidence that negative geotaxis, namely the ability to find perches off the ground as resting sites, is a fundamental innate behaviour of freshly emerged *G. pallidipes*. Under dark conditions freshly emerged *G. pallidipes* walked away from the emergence site to climb up upright bars in the seconds following emergence. Above all, freshly-emerged *G. pallidipes* fly to suspended bars under dark conditions. This underlines the role of night vision in the survival strategies in tsetse and shows how resting sites are important early in tsetse fly life history. Secondly, I thought that an understanding of resting behaviours of tsetse may be a key to increase their landing responses on 2D targets. Indeed, I show in the wind tunnel that when a 3D object consisting of a horizontal black bar simulating a resting site is incorporated at the bottom of a 2D blue target, first and subsequent landings by *G. pallidipes* on it increase by a factor of 2. Of course,

this finding needs to be confirmed in the field for this and others tsetse species in the context of the standardization of tools for tsetse control. Further, tsetse population control cannot be dealt with without touching on the question of insecticide. For this, the efficacy of different textiles with increasing proportions of polyester to retain deltamethrin under field conditions was examined. Textiles made of 100% polyester and impregnated by immersion in 0.1% aqueous solution of deltamethrin can kill tsetse for up to 9 months in the field, the duration long enough to reduce even high densities of tsetse. However, textiles were weathered in the Lambwe Valley (Kenya) where rainfall peaks was ca. 200 mm during the month of April. Weathering polyester textiles in an area of heavier rainfall to fully investigate their efficacy to retain deltamethrin for tsetse control is desirable.

Tsetse population control encounters many obstacles. Changes in the dominant vegetation in endemic regions of trypanosomiasis when pasture lands revert to dense bush during rainy season leads to the expansion of the distribution of tsetse (Waller, 1990, Bouyer et al., 2015, Dicko et al., 2014). The use of tiny targets placed at 15 - 30 cm above the ground for riverine tsetse can be rendered inoperative when covered over by dense vegetation (Esterhuizen et al., 2011a). It therefore becomes necessary to elevate the height of targets for tsetse populations control under such conditions. Planting poles in the ground is required to support 2D targets deployed in the field where the soil is hard to dig, especially in the case of arid areas where Morsitans tsetse are found. Poles are usually made of wood and therefore can be attacked by moisture and termites after few weeks. In the case of the Central African Republic where entomological surveys of tsetse have not been done for a long time (the 1970s) little is known about tsetse species in the four main foci of trypanosomiasis in the country (see General introduction, Fig. 1.9). One can expect to encounter overlapping distributions of tsetse species. Using a standardized cost-effective visual targets for control campaigns of tsetse is recommended for the country. Blue tiny targets with a black bar at the bottom present several advantages permitting to deal with these practical problems. Firstly, the black-coloured resting site at the bottom of the blue target should ensure functioning of the device when elevated at more than 1 m above the ground level as all tsetse species use horizontal resting sites at above such an elevation (Abdurrahim, 1971, Okiwelu, 1976, Omoogun, 1985) although tsetse only fly at 0.2 – 0.4 m above the ground (Bursell, 1984, Gibson and Brady, 1988, Torr, 1988a). This is especially of interest in Central and West Africa

where vegetation grows rapidly during the rainy season and where riverine tsetse are abundant. A recent study on the sympatric species *G. palpalis gambiensis* and *G. tachinoides* in forest galleries of south west Burkina Faso (Salou et al., 2016) showed that (1) when such species approach humans *G. palpalis gambiensis* preferentially attacks the upper body parts like the back whereas *G. tachinoides* attacks lower parts of the body such as the ankles and (2) no difference was found on preferential heights of these species on targets. This supports the idea that it is possible to develop visual targets of standardized design for controlling different tsetse species living in the same locality, focusing on their attractiveness to targets with a predominating horizontal component (Table 1.9, Chapter 1), with a blue and black colour contrast and the presence of a 3D landing stimulus.

Secondly, to avoid to dig the soil for fixing the targets, suspending them from bushes or trees is an option. Bars 2 cm in diameter with a certain weight inserted into a horizontal pouch made of matt black tissue at the bottom of the blue target would be sufficient to stretch the suspended target made of textile and thus facilitate deployment. For this, it would be better to use metal bars. Water retention in the case of wooden bars would result in exchange of water leading to the diffusion of deltamethrin from the cloth into the wooden bar and, consequently, decreases the retention of the insecticide on the black textile covering the bar. A low amount of deltamethrin is recommended to treat targets deployed for riverine tsetse in forest galleries along rivers as deltamethrin is known to be highly toxic to fish (Kumar et al., 1999, Köprücü and Aydın, 2004). A 0.1% deltamethrin formulation in water, corresponding to an initial concentration of ca. 250 mg/m<sup>2</sup> on phthalogen blue and matt black textiles (weight ca. 250 g/m<sup>2</sup>) with 65% or 100% polyester would be acceptable to limit environmental consequences and remain operable over one year for tsetse control.

In perspective, I plan to explore in the field the efficacy of the 25 cm x 25 cm blue target with black round bar at the base. Recent studies on the efficiency of 2D targets for tsetse control in the field have used phthalogen blue tissue with 100% cotton. To implement field studies on the basis of my results, phthalogen blue and matt black textiles with 100% polyester should be used. Field trials could be conducted in two foci of trypanosomiasis (foci of Ouham and Nola, Fig. 1.9) in the Central Africa Republic. These sites are chosen for the following reasons:

- These sites correspond to two different climatic area (dense forest and savannah) found in the country;
- The focus of Ouham is situated in the north-west savannah area where *G. tachinoides* and *G. f. fuscipes* is found. However, the presence of *G. m. morsitans* and *G. morsitans submorsitans* have been reported in this focus (Rogers and Robinson, 2004);
- The focus of Nola is situated in the south-west forest area where rainfall is usually high compared to elsewhere in the country and where *G. p. palpalis* and *G. f. fuscipes* are abundant.

In the focus of Ouham the target plus the black bar at the bottom can be tested:

- i. in comparison to the all-blue target alone;
- ii. at different elevations up to 2 m above the ground;
- iii. suspended *versus* totally immobilized at a certain elevation in order to assess whether movement in the wind of the suspended visual target plus the black bar can enhance its attractiveness to tsetse.

Further, transparent blue plastic sheets equipped with black 3D bars at their bases and coated with glue (ex. Tanglefoot®) can be used to retain tsetse that alight on them for monitoring purpose. In addition, biconical traps and an alternative trap for Morsitans tsetse (see General introduction, Fig. 1.7) could be used for comparison to the blue targets plus black bar at the bottom in case Morsitans tsetse are present. The two targets (all-blue and blue plus the black bar), biconical and a trap chosen for Morsitans tsetse can be compared in a 4 x 4 Latin square design as monitoring devices.

In the focus of Nola, due to heavy rainfall that can reach 3000 mm during months of June and July, tests on deltamethrin retention on targets should be conducted to fully investigate the efficiency of polyester textile to retain insecticide and to compare to results obtained in Kenya where rainfall hardly reached 200 mm. Two sites can be chosen in two different districts at least 50 km from each other. Deltamethrin-impregnated visual blue targets incorporating the black bars at the bottom could be deployed in a site. At the other site considered as control, deltamethrin-impregnated all-blue target could be deployed. Targets can be treated by impregnation in a 1% deltamethrin formulation in water. As only

Palpalis tsetse exist in the focus of Nola, biconical traps will be used for monitoring the pattern of the decline of tsetse populations at the two sites over one year. Blue and black polyester textiles samples used to make targets can be impregnated with deltamethrin and weathered under same conditions simultaneously to the study. These textile samples can be collected every three months and tested for their ability to kill tsetse caught in biconical traps. The remaining dose of deltamethrin on targets can be estimated using the linear regression model determined in this study for the determination of the  $LD_{50}$  for deltamethrin (see Fig. 4.4b, chapter 4). In the case of heavy rainfall where the toxicity of insecticide-impregnated targets against tsetse drops off after some months, respraying targets would be necessary by reapplying deltamethrin mainly to the bottom parts of targets. Such a plan would serve to launch field professionals with a new perspective in Central African Republic foci of trypanosomiasis that have been long neglected.

## References

- ABDURRAHIM, U. 1971. A study of the diurnal resting behaviour of *Glossina palpalis* in Southern Zaria, Northern Nigeria. *ISTRC 13th Meeting*, 213-227.
- AGEE, H. R. 1971. Flicker Fusion Frequency of the Compound Eye of *Heliothis zea* (Lepidoptera: Noctuidae). *Annals of the Entomological Society of America*, 64, 942-945.
- AUTRUM, H. 1950. Die Belichtungspotentiale und das Sehen der Insekten (Untersuchungen an *Calliphora* und *Dixippus*). *Zeitschrift für vergleichende Physiologie*, 32, 174-227.
- AUTRUM, H. & GALLLWITZ, M. 1951. Zur Analyse der Belichtungspotentiale des Insektenauges. *Zeitschrift für vergleichende Physiologie*, 33, 407-435.
- AUTRUM, H. & STOECKER, M. 1950. Die Verschmelzungsfrequenzen des Bienenauges. *Z Naturforsch C*, 5b, 38-43.
- BAILLY, C., MAMADOU, Y. & ROUNGOU, J. 1990. La trypanosomiase humaine en RCA: historique, épidémiologie, actualité. *Bull. Iias. Doc. OCEAC.*, 93, 12-16.
- BAR-ZEEV, M. 1960. The reaction of mosquitoes to moisture and high humidity. *Entomologia Experimentalis et Applicata*, 3, 198-211.
- BARLOW, S. M., SULLIVAN, F. M. & LINES, J. 2001. Risk assessment of the use of deltamethrin on bednets for the prevention of malaria. *Food Chem Toxicol*, 39, 407-22.
- BOUYER, J., DESQUESNES, M., KABORÉ, I., DIA, M. L., GILLES, J., YONI, W. & CUISANCE, D. 2005. Santé animale en Afrique de l'Ouest: Le piégeage des insectes vecteurs. *CIRDES-CIRAD*, Fiche N°20.
- BOUYER, J., DICKO, A. H., CECCHI, G., RAVEL, S., GUERRINI, L., SOLANO, P., VREYSEN, M. J. B., DE MEEÛS, T. & LANCELOT, R. 2015. Mapping landscape friction to locate isolated tsetse populations that are candidates for elimination. *Proceedings of the National Academy of Sciences*.
- BRAITENBERG, V. & FERRETTI, C. 1966. Landing reaction of *Musca domestica* induced by visual stimuli. *Naturwissenschaften*, 53, 155-155.
- BRIGHTWELL, R., DRANSFIELD, R. D., KYORKU, C., GOLDBERGER, T. K., TARIMO, S. A. & MUNGAI, D. 1987. A new trap for *Glossina pallidipes*. *Tropical Pest Management*, 33, 151-159.
- BRUNHES, J., CUISANCE, D., GEOFFROY, B., HERVY, J. P. & LEBBE, J. 1998. Les glossines ou mouches tsé-tsé. Logiciel d'identification et d'enseignement. Eds ORSTOM, Montpellier, France.
- BURNETT, G. F. 1961. Effect of age and pregnancy on the tolerance of tsetse flies to insecticides. *Nature*, 192, 188.
- BURSELL, E. 1958. The Water Balance of Tsetse Pupae. *Philosophical Transactions of the Royal Society of London B: Biological Sciences*, 241, 179-210.
- BURSELL, E. 1960. The Measurement of Size in tsetse flies (*Glossina*). *Bulletin of Entomological Research*, 51, 33-37.
- BURSELL, E. 1984. Observations on the orientation of tsetse flies (*Glossina pallidipes*) to wind-borne odours. *Physiological Entomology*, 9, 133-137.
- BURSELL, E. & TAYLOR, P. 1980. An energy budget for *Glossina* (Diptera: Glossinidae). *Bulletin of Entomological Research*, 70, 187-196.
- BURTT, E. T. & CATTON, W. T. 1960. The properties of single-unit discharges in the optic lobe of the locust. *The Journal of Physiology*, 154, 479-490.
- CAREY, J. R. 2001. Insect biogeography. *Annu Rev Entomol*, 46, 79-110.
- CHALLIER, A., EYRAUD, M., LAFAYE, A. & LAVEISSIÈRE, C. 1977. Amélioration du rendement du piège biconique pour glossines (Diptera, Glossinidae) par l'emploi d'un cône inférieur bleu. *Cah OR STOM Ser. Ent. Med. Parasitol.*, 15, 283-286.
- CHALLIER, A. & LAVEISSIÈRE, C. 1973. Un nouveau piège pour la capture des glossines (*Glossina*: Diptera, Muscidae): description et essais sur le terrain. *Cah OR STOM Ser. Ent. Med. Parasitol.*, 11, 251-262.
- CHALMERS, A. E., MILLER, T. A. & OLSEN, R. W. 1987. Deltamethrin: A neurophysiological study of the sites of action. *Pesticide Biochemistry and Physiology*, 27, 36-41.
- CHAPPUIS, C. J. F. 2013. *The behaviour of tsetse fly Glossina pallidipes (Diptera, Glossinidae): from host seeking to biting*. PhD, University of Neuchâtel.
- CHAPPUIS, C. J. F., BEGUIN, S., VLIMANT, M. & GUERIN, P. M. 2013. Water vapour and heat combine to elicit biting and biting persistence in tsetse. *Parasites & Vectors*, 6.

- CHAVASSE, D. C. & YAP, H. H. 1997. Chemical Methods for the Control of Vectors and Pests of Public Health Importance. World Health Organization, Geneva.
- CHORLEY, T. W. & HOPKINS, G. H. E. 1942. Activity of *G. pallidipes* at night (Diptera). *Proceedings of the Royal Entomological Society of London. Series A*, 17, 93-97.
- CIE 1951. Commission Internationale de l'Éclairage Proceedings. *Bureau Central de la CIE, Vol. 1 Sec 4; Vol. 3*, 37.
- CLARK, J. M. & BROOKS, M. W. 1989. Role of ion channels and intraterminal calcium homeostasis in the action of deltamethrin at presynaptic nerve terminals. *Biochemical Pharmacology*, 38, 2233-2245.
- COCKERELL, T. D. A. 1917. A fossil tsetse fly and other Diptera from Florissant, Colorado. *Proceedings of the Biological Society of Washington*, 30, 19-22.
- CONTOR, C. R. & GRIFFITH, J. S. 1995. Nocturnal emergence of juvenile rainbow trout from winter concealment relative to light intensity. *Hydrobiologia*, 299, 179-183.
- CRAWLEY, M. J. 1993. *GLIM for ecologists*. Blackwell Scientific Publication, Oxford.
- CROOKS, E. & RANDOLPH, S. E. 2006. Walking by Ixodes ricinus ticks: intrinsic and extrinsic factors determine the attraction of moisture or host odour. *J Exp Biol*, 209, 2138-42.
- DA COSTA, B., SANTANA, J., SANTOS, A. & ALVARES, M. 1916. Sleeping sickness, a record of four years war against it in Principe, Portugues, West Africa. *Ballière, Tindall and Cox*. London.
- DAGNOGO, M., NEKPENI, E. & EOUZAN, J. E. A. 1986. Utilisation du piégeage dans la lutte anti-tsétsé: effets des supports traités et non traités. *Trop. Med. Parasit.*, 74, 261-276.
- DE DEKEN, R., VAN DEN BOSSCHE, P. & VAN HEES, J. 1998. Susceptibility of Tsetse Flies to Topical Applications of Deltamethrin. *Annals of the New York Academy of Sciences*, 849, 450-455.
- DELAS, E. 1972. Essai de lutte contre les glossines dans un foyer de trypanosomiase en RCA. *Conf. Techn. de l'OCEAC*, 530-540.
- DESQUESNES, M. & DIA, M. L. 2003a. Mechanical transmission of Trypanosoma congolense in cattle by the African tabanid Atylotus agrestis. *Exp Parasitol*, 105, 226-31.
- DESQUESNES, M. & DIA, M. L. 2003b. Trypanosoma vivax: mechanical transmission in cattle by one of the most common African tabanids, Atylotus agrestis. *Exp Parasitol*, 103, 35-43.
- DIA, M. L., DESQUESNES, M., HAMADOU, S., BOUYER, J., YONI, W. & GOURO, A. S. 2008 Tetra Trap: Evaluation of a small model for catching animal trypanosomosis vectors. *Rév. Méd. Vét*, 1, 17-21.
- DICKO, A. H., LANCELOT, R., SECK, M. T., GUERRINI, L., SALL, B., LO, M., VREYSEN, M. J., LEFRANCOIS, T., FONTA, W. M., PECK, S. L. & BOUYER, J. 2014. Using species distribution models to optimize vector control in the framework of the tsetse eradication campaign in Senegal. *Proc Natl Acad Sci U S A*, 111, 10149-54.
- DOKU, C. & BRADY, J. 1989. Landing site preferences of Glossina morsitans morsitans Westwood (Diptera: Glossinidae) in the laboratory: avoidance of horizontal features? *Bulletin of Entomological Research*, 79, 521-528.
- ESENA, R. K. 2013. A New Trap For Glossina Morsitans as a Strategy for Quality Improvement of African Trypanosomiasis Control. *Journal of Biology, Agriculture and Healthcare*, 3, 54-66.
- ESTERHUIZEN, J., NJIRU, B., VALE, G. A., LEHANE, M. J. & TORR, S. J. 2011a. Vegetation and the Importance of Insecticide-Treated Target Siting for Control of *Glossina fuscipes fuscipes*. *PLoS Negl Trop Dis*, 5, e1336.
- ESTERHUIZEN, J., RAYAISSE, J. B., TIRADOS, I., MPIANA, S., SOLANO, P., VALE, G. A., LEHANE, M. J. & TORR, S. J. 2011b. Improving the Cost-Effectiveness of Visual Devices for the Control of Riverine Tsetse Flies, the Major Vectors of Human African Trypanosomiasis. *PLoS Negl Trop Dis*, 5, e1257.
- EZOUAN, J. & FERRERA, L. 1973. Résultats d'une campagne de lutte contre les glossines en RCA. *Conf. Techn. de l'OCEAC*, 197-198.
- FAO 1998. Spotlight on the cost of trypanosomiasis. [www.fao.org/ag/magazine/spot1.htm](http://www.fao.org/ag/magazine/spot1.htm).
- FINELLE, P., ITARD, J., YVORE, P. & LACOTTE, R. 1963. Répartition des glossines en RCA, état actuel des connaissances. *Rev. Elev. Méd. Vét. Pays trop*, 16(3), 337-348.

- FLINT, S. 1985. A comparison of various traps for *Glossina* spp. (Glossinidae) and other Diptera. *Bulletin of Entomological Research*, 75, 529-534.
- GIBSON, G. & BRADY, J. 1985. 'Anemotactic' flight paths of tsetse flies in relation to host odour: a preliminary video study in nature of the response to loss of odour. *Physiological Entomology*, 10, 395-406.
- GIBSON, G. & BRADY, J. 1988. Flight behaviour of tsetse flies in host odour plumes: the initial response to leaving or entering odour. *Physiological Entomology*, 13, 29-42.
- GIBSON, G., PACKER, M. J., STEULLET, P. & BRADY, J. 1991. Orientation of Tsetse-Flies to Wind, within and Outside Host Odor Plumes in the Field. *Physiological Entomology*, 16, 47-56.
- GIBSON, G. & YOUNG, S. 1991. The optics of tsetse fly eyes in relation to their behaviour and ecology. *Physiological Entomology*, 16, 273-282.
- GIMNIG, J. E., LINDBLADE, K. A., MOUNT, D. L., ATIEMI, F. K., CRAWFORD, S., WOLKON, A., HAWLEY, W. A. & DOTSON, E. M. 2005. Laboratory wash resistance of long-lasting insecticidal nets. *Trop Med Int Health*, 10, 1022-9.
- GOODMAN, L. J. 1960. The Landing Responses of Insects: I. The Landing Response of the Fly, *Lucilia Sericata*, and Other Calliphorinae. *Journal of Experimental Biology*, 37, 854-878.
- GOUTEUX, J. & LANCIEN, J. 1986. Le piège pyramidal à tsetse (Diptera: Glossinidae) pour la capture et la lutte. Essai comparatif et description de nouveaux systèmes de capture. *Trop. Med. Parasit.*, 37, 61-66.
- GREEN, C. & COSENS, D. 1983. Spectral responses of the tsetse fly *Glossina morsitans morsitans*. *Journal of Insect Physiology*, 29, 795-800.
- GREEN, C. H. 1988. The effect of colour on trap- and screen-orientated responses in *Glossina palpalis palpalis* (Robineau-Desvoidy) (Diptera: Glossinidae). *Bulletin of Entomological Research*, 78, 591-604.
- GREEN, C. H. 1989. The use of two-coloured screens for catching *Glossina palpalis palpalis* (Robineau-Desvoidy) (Diptera: Glossinidae). *Bulletin of Entomological Research*, 79, 81 - 83.
- GURBA, A., HARRACA, V., PERRET, J. L., CASERA, S., DONNET, S. & GUERIN, P. M. 2012. Three-dimensional flight tracking shows how a visual target alters tsetse fly responses to human breath in a wind tunnel. *Physiological Entomology*, 37, 250-257.
- HARDIE, R., VOGT, K. & RUDOLPH, A. 1989. The compound eye of the tsetse fly (*Glossina morsitans morsitans* and *Glossina palpalis palpalis*). *Journal of Insect Physiology*, 35, 423-431.
- HARGROVE, J. 1980. The effect of model size and ox odour on the alighting responses of *Glossina morsitans* Westwood and *G. pallidipes* Austen (Diptera: Glossinidae). *Bulletin of Entomological Research*, 70, 229-234.
- HARGROVE, J. W. 1994. Reproductive rates of tsetse flies in the field in Zimbabwe. *Physiological Entomology*, 19, 307-318.
- HARGROVE, J. W. 1999. Nutritional levels of female tsetse *Glossina pallidipes* from artificial refuges. *Medical and Veterinary Entomology*, 13, 150-164.
- HARGROVE, J. W. 2004. Tsetse population dynamics. In: MAUDLIN, I., HOLMES, P. H. & MILES, M. A. (eds.) *The Trypanosomiases*. CABI Publishing.
- HARGROVE, J. W. & PACKER, M. J. 1993. Nutritional states of male tsetse flies (*Glossina* spp.) (Diptera: Glossinidae) caught in odour-baited traps and artificial refuges: models for feeding and digestion. *Bulletin of Entomological Research*, 83, 29-46.
- HARGROVE, J. W., TORR, S. J. & KINDNESS, H. M. 2003. Insecticide-treated cattle against tsetse (Diptera: Glossinidae): what governs success? *Bull Entomol Res*, 93, 203-17.
- HARLEY, J. M. B. 1954. The breeding sites of the tsetse fly *Glossina morsitans*. *Acta Trop*, 11, 379-401.
- HASSENSTEIN, B. 1951. Ommatidienraster und afferente Bewegungsintegration. *Z. vergl. Physiol.*, 33, 301.
- HUYTON, P. M. & BRADY, J. 1975. Some effects of light and heat on the feeding and resting behaviour of tsetse flies, *Glossina morsitans* Westwood. *Journal of Entomology Series A, General Entomology*, 50, 23-30.
- JEWELL, G. R. 1958. Detection of Tsetse Fly at Night. *Nature*, 181, 1354-1354.

- KABA, D., ZACARIE, T., M'PONDI, A. M., NJIOKOU, F., BOSSON-VANGA, H., KRÖBER, T., MCMULLIN, A., MIHOK, S. & GUERIN, P. M. 2014. Standardising Visual Control Devices for Tsetse Flies: Central and West African Species *Glossina palpalis palpalis*. *PLoS Negl Trop Dis*, 8, e2601.
- KAPPMEIER, K. 2000a. Diurnal activity patterns of *Glossina brevipalpis* and *G. austeni* (Diptera: Glossinidae) in South Africa, with reference to season and meteorological factors. *Onderstepoort J Vet Res*, 67, 179-89.
- KAPPMEIER, K. 2000b. A newly developed odour-baited "H trap" for the live collection of *Glossina brevipalpis* and *Glossina austeni* (Diptera: Glossinidae) in South Africa. *Onderstepoort J Vet Res*, 67, 15-26.
- KAVLOCK, R., CHERNOFF, N., BARON, R., LINDER, R., ROGERS, E., CARVER, B., DILLEY, J. & SIMMON, V. 1979. Toxicity studies with decamethrin, a synthetic pyrethroid insecticide. *J Environ Pathol Toxicol*, 2, 751-65.
- KESSLER, S. & GUERIN, P. M. 2008. Responses of *Anopheles gambiae*, *Anopheles stephensi*, *Aedes aegypti*, and *Culex pipiens* mosquitoes (Diptera: Culicidae) to cool and humid refugium conditions. *J Vector Ecol*, 33, 145-9.
- KNOLS, B. G., WILLEMSE, L., FLINT, S. & MATE, A. 1993. A trial to control the tsetse fly, *Glossina morsitans centralis*, with low densities of odour-baited targets in west Zambia. *Med Vet Entomol*, 7, 161-9.
- KOFFI, M., MEEÛS, T. D., BUCHETON, B., SOLANO, P., CAMARA, M., KABA, D., CUNY, G., JAMONNEAU, V. & AYALA, F. J. 2009. Population Genetics of *Trypanosoma brucei gambiense*, the Agent of Sleeping Sickness in Western Africa. *Proceedings of the National Academy of Sciences of the United States of America*, 106, 209-214.
- KÖPRÜCÜ, K. & AYDIN, R. 2004. The toxic effects of pyrethroid deltamethrin on the common carp (*Cyprinus carpio* L.) embryos and larvae. *Pesticide Biochemistry and Physiology*, 80, 47-53.
- KUMAR, S., LATA, S. & GOPAL, K. 1999. Deltamethrin induced physiological changes in freshwater cat fish *Heteropneustes fossilis*. *Bull Environ Contam Toxicol*, 62, 254-8.
- LANCIEN, J. 1981. Description du piège monoconique utilisé pour l'élimination des glossines en République Populaire du Congo. *Cahiers ORSTOM. Sér Ent. Méd. et Parasit.*, 19, p. 235-238.
- LANGLEY, P. A. & MALY, H. 1969. Membrane Feeding Technique for Tsetse Flies (*Glossina* spp.). *Nature*, 221, 855-856.
- LAVEISSIERE, C., COURET, D., GREBAUT & P. 1988. *Recherche sur les écrans pour la lutte contre les glossines en région forestière de Côte d'Ivoire. Mise au point d'un nouvel écran*, Paris, FRANCE, Office de la recherche scientifique et technique Outre-mer.
- LAVEISSIÈRE, C., COURET, D. & MANNO, A. E. A. 1985. Tests d'efficacité et de rémanence d'insecticides utilisés en imprégnation sur tissus pour la lutte par piégeage contre les glossines. 2 - Première série de tests en saison humide et en saison sèche. *Cahier ORSTOM, sér. Ent. méd. et Parasit.*, 23, 217-230.
- LAVEISSIERE, C. & GREBAUT, P. 1990. Research on the tsetse (Diptera: Glossinidae) traps. Perfection of an economic model: the "Vavoua" trap. *Trop. Med. Parasit.*, 41, 185-192.
- LEAK, S. G. A. 1999. *Tsetse biology and ecology : their role in the epidemiology and control of trypanosomosis*, Wallingford, CABI Publishing in association with the International Livestock Research Institute.
- LENGELER, C. 2004. Insecticide-treated bed nets and curtains for preventing malaria. *Cochrane Database Syst Rev*, CD000363.
- LINDH, J. M., TORR, S. J., VALE, G. A. & LEHANE, M. J. 2009. Improving the Cost-Effectiveness of Artificial Visual Baits for Controlling the Tsetse Fly *Glossina fuscipes fuscipes*. *PLoS Negl Trop Dis*, 3, e474.
- MANGWIRO, T. N., TORR, S. J., COX, J. R. & HOLLOWAY, M. T. 1999a. The efficacy of various pyrethroid insecticides for use on odour-baited targets to control tsetse. *Med Vet Entomol*, 13, 315-23.
- MANGWIRO, T. N. C., TORR, S. J., COX, J. R. & HOLLOWAY, M. T. P. 1999b. The efficacy of various pyrethroid insecticides for use on odour-baited targets to control tsetse. *Medical and Veterinary Entomology*, 13, 315-323.

- MBELESSO, P., MBADINGAI, S. & LAGHOE NGUEMBE, G. L. S. 2011. Vers la maîtrise de l'endémie sommeilleuse dans le foyer de Nola-Bilolo en Centrafrique. *Bulletin de la Société de pathologie exotique.*, 104, 361-365.
- MCDONALD, W. A. 1960. Nocturnal Detection of Tsetse Flies in Nigeria with Ultra-Violet Light. *Nature*, 185, 867-868.
- MEROT, P., POLITZAR, H., TAMBOURA, I. & CUISANCE, D. 1984. Results of a control campaign against river tsetse flies in Burkina using deltamethrin-impregnated screens. *Rev Elev Med Vet Pays Trop*, 37, 175-84.
- MIALL, R. C. 1978. The flicker fusion frequencies of six laboratory insects, and the response of the compound eye to mains fluorescent 'ripple'. *Physiological Entomology*, 3, 99-106.
- MIHOK, S. 2002. The development of a multipurpose trap (the Nzi) for tsetse and other biting flies. *Bull Entomol Res*, 92, 385-403.
- MINTER, D. M. 1971. The nocturnal resting sites of *Glossina pallidipes* in Kenya. *Trans. R. soc. Trop. med. hyg.*, 65, 228-229.
- MOGGRIGE, J. Y. 1948. Night activity of tsetse (*Glossina*) on the Kenya coast. *Proceedings of the Royal Entomological Society of London. Series A, General Entomology*, 23, 87-92.
- MOLOO, S. K., KUTUZA, S. B. & BOREHAM, P. F. 1980. Studies on *Glossina pallidipes*, *G. fuscipes fuscipes* and *G. brevipalpis* in terms of the epidemiology and epizootiology of trypanosomiasis in south-eastern Uganda. *Ann Trop Med Parasitol*, 74, 219-37.
- MORRIS, K. R. S. 1963. A study of African tabanids made by trapping. *Acta Tropica*, 20.
- MORRIS, K. R. S. & MORRIS, M. G. 1949. The use of Traps against Tsetse in West Africa. *Bulletin of Entomological Research*, 39, 491-528.
- MRAMBA, F., OLOO, F., BYAMUNGU, M., KRÖBER, T., MCMULLIN, A., MIHOK, S. & GUERIN, P. M. 2013. Standardizing Visual Control Devices for Tsetse Flies: East African Species *Glossina swynnertoni*. *PLoS Negl Trop Dis.*, 7, e2063.
- MUIRHEAD-THOMSON, R. C. 1991. Chapter 7 - Responses of blood-sucking flies to visual traps. In: MUIRHEAD-THOMSON, R. C. (ed.) *Trap Responses of Flying Insects*. London: Academic Press.
- NASH, T. A. M. 1952. Some Observations on resting Tsetse-fly Populations, and Evidence that *Glossina medicorum* is a Carrier of Trypanosomes. *Bulletin of Entomological Research*, 43, 33-42.
- NDEGWA, P. N. & MIHOK, S. 1999. Development of odour-baited traps for *Glossina swynnertoni* (Diptera: Glossinidae). *Bulletin of Entomological Research*, 89, 255-261.
- NGOUMALE, G. 1984. *La trypanosomiase humaine: étude du foyer* Thèse de médecine.
- NGUEMBI, E. 1982. *La trypanosomiase humaine dans la région de Nola: du foyer historique au foyer résiduel*. Thèse de médecine.
- OKIWELU, S. N. 1976. Resting sites of *Glossina morsitans morsitans* Westwood (Diptera: Glossinidae) during the dry season in the republic of Zambia. *Bulletin of Entomological Research*, 66, 413-419.
- OKIWELU, S. N. 1977. Observations of resting sites of *Glossina morsitans morsitans* (Diptera: Muscidae) during the wet season in the republic of Zambia, Africa. *J. Med. Ent.*, 13, 595-599.
- OKIWELU, S. N. 1982. Resting site preferences of tsetse *Glossina morsitans submorsitans* Newstead (Diptera: Glossinidae) in Mali. *Insect sci. Application*, 3, 151-156.
- OKIWELU, S. N. 1983. Further observations on the resting site preferences of the tsetse *Glossina palpalis gambiensis* Vanderplank (Diptera: Glossinidae) in Mali. *Insect sci. Application*, 4, 305-308.
- OKOTH, J. O. & KAPAATA, R. 1987. A study of the resting sites of *Glossina fuscipes fuscipes* (Newstead) in relation to Lantana camara thickets and coffee and banana plantations in the sleeping sickness epidemic focus, Busoga, Uganda. *International Journal of Tropical Insect Science*, 8, 57-60.
- OLOO, F., SCIARRETTA, A., MOHAMED-AHMED, M. M., KROBER, T., MCMULLIN, A., MIHOK, S. & GUERIN, P. M. 2014. Standardizing visual control devices for tsetse flies: east African Species *Glossina fuscipes fuscipes* and *Glossina tachinoides*. *PLoS Negl Trop Dis*, 8, e3334.

- OMOOGUN, G. A. 1985. The resting behaviour of *Glossina longipalpis* (Wiedemann) and *Glossina fusca congolensis* (Newstead & Evans) at Oke-Ako, Nigeria. *International Journal of Tropical Insect Science*, 6, 83-89.
- PHELPS, R. J. & CLARKE, G. P. Y. 1974. Seasonal elimination of some size classes in males of *Glossina morsitans morsitans* Westw. (Diptera, Glossinidae). *Bulletin of Entomological Research*, 64, 313-324.
- PILSON, R. D. & LEGGATE, B. M. 1962. A diurnal and seasonal study of the resting behaviour of *Glossina pallidipes* Aust. *Bulletin of Entomological Research*, 53, 551-562.
- PRIOTTO, G., KASPARIAN, S., MUTOMBO, W., NGOUAMA, D., GHORASHIAN, S., ARNOLD, U., GHABRI, S., BAUDIN, E., BUARD, V., KAZADI-KYANZA, S., ILUNGA, M., MUTANGALA, W., POHLIG, G., SCHMID, C., KARUNAKARA, U., TORREELE, E. & KANDE, V. 2009. Nifurtimox-eflornithine combination therapy for second-stage African *Trypanosoma brucei gambiense* trypanosomiasis: a multicentre, randomised, phase III, non-inferiority trial. *The Lancet*, 374, 56-64.
- R CORE TEAM 2016. R: A language and environment for statistical computing. Vienna, Austria. URL <https://www.R-project.org/>: R Foundation for Statistical Computing.
- RANDOLPH, S. E., WILLIAMS, B. G., ROGERS, D. J. & CONNOR, H. 1992. Modelling the effect of feeding-related mortality on the feeding strategy of tsetse (Diptera: Glossinidae). *Medical and Veterinary Entomology*, 6, 231-240.
- RAYAISSE, J.-B., KRÖBER, T., MCMULLIN, A., SOLANO, P., MIHOK, S. & GUERIN, P. M. 2012. Standardizing Visual Control Devices for Tsetse Flies: West African Species *Glossina tachinoides*, *G. palpalis gambiense* and *G. morsitans submorsitans*. *PLoS Negl Trop Dis*, 6, e1491.
- RAYAISSE, J. B., ESTERHUIZEN, J., TIRADOS, I., KABA, D., SALOU, E., DIARRASSOUBA, A., VALE, G. A., LEHANE, M. J., TORR, S. J. & SOLANO, P. 2011. Towards an Optimal Design of Target for Tsetse Control: Comparisons of Novel Targets for the Control of Palpalis Group Tsetse in West Africa. *PLoS Negl Trop Dis*, 5, e1332.
- RCA 1994. Ministère de la Santé Publique et de la Population. Problématique de la lutte anti-vectorielle dans le foyer trypanique de Nola (Sangha-Mbaéré) en Rép. Centrafricaine. Rapport Annuel d'Activités de Surveillance Epidémiologique. 36p.
- RCA 2008. Rapport National d'Investissement. *L'eau pour l'agriculture et l'énergie en Afrique : Les défis du changement climatique*. Décembre 2008, Syrte, Jamahiriya Arabe Libyenne.
- RIORDAN, E. K. 1987. Insecticide tolerance of pregnant females of *Glossina palpalis palpalis* (Robineau-Desvoidy) (Diptera: Glossinidae). *Bulletin of Entomological Research*, 77, 213-226.
- ROGERS, D. & ROBINSON, T. 2004. *Tsetse distribution: The Trypanosomiases*, Wallingford, Oxfordshire, UK, CABI Publishing.
- ROWELL, C. H. F. 1971. The orthopteran descending movement detector (DMD) neurones: a characterisation and review. *Zeitschrift für vergleichende Physiologie*, 73, 167-194.
- SALOU, E., RAYAISSE, J. B., KABA, D., DJOHAN, V., YONI, W., BARRY, I., DOFINI, F., BOUYER, J. & SOLANO, P. 2016. Variations in attack behaviours between *Glossina palpalis gambiense* and *G. tachinoides* in a gallery forest suggest host specificity. *Med Vet Entomol*.
- SCHOLZ, E., SPIELBERGER, U. & ALI, J. 1976. The night resting sites of the tsetse fly *Glossina palpalis palpalis* (Robineau-Desvoidy) (Diptera, Glossinidae) in northern Nigeria. *Bulletin of Entomological Research*, 66, 443-452.
- SHAW, A. 2004. Economics of African Trypanosomiasis. In: MAUDLIN I, HOLMES PH & MA, M. (eds.) *The Trypanosomiases*. Wallingford: CABI Publishing.
- SIMARRO, P., CECCHI, G., FRANCO, J., PAONE, M., FEVRE, E., DIARRA, A., RUIZ, J., MATTIOLI, R. & JANNIN, J. 2012. Estimating and mapping the population at risk of sleeping sickness. *PLoS Negl Trop Dis*, 6, e1859.
- SIMARRO, P., JANNIN, J. & CATTAND, P. 2008. Eliminating human african trypanosomiasis: where do we stand and what comes next. *PLoS Med*, 5, e55.

- SOLANO, P. & AMSLER DELAFOSSE, S. 1995. *Trypanosoma congolense* chez différentes espèces de taons (Diptera: Tabanidae) au Burkina Faso. *Rev Elev Med Vet Pays Trop*, 48, 145-146.
- SOUTHON, H. A. W. 1956. Predation on Glossina. East African Trypanosomiasis Research organisation Annual Report. E.A. High Commission, Nairobi. 53.
- SOUTHON, H. A. W. 1958. Studies on predation of Glossina. East African Trypanosomiasis Research organisation Annual Report. E.A. High Commission, Nairobi. 56-58.
- SPIELBERGER, U. & BARWINEK, F. 1978. The night resting sites of Glossina tachinoides Westwood (Diptera: Glossinidae) in northern Nigeria. *Bulletin of Entomological Research*, 68, 137-144.
- SPURLOCK, F. & LEE, M. 2008. Synthetic pyrethroid use patterns, properties, and environmental effects. ACS Symposium Series, Environmental Monitoring Branch, California Department of Pesticide Regulation, Sacramento, CA. pp. 3-25.
- SWYNNERTON, C. F. M. 1936. Tsetse flies of East Africa: A first study of their ecology with a view to their control. *Trans. R. soc. Trop. Lond*, 84, 579.
- TADDEI-FERRETTI, C. & PEREZ DE TALENS, A. F. 1973. Landing reaction of Musca domestica. IV. A monocular and binocular vision; B. relationships between landing and optomotor reactions. *Z Naturforsch C*, 28, 579-92.
- TAYLOR, P. 1977. A continuously recording respirometer, used to measure oxygen consumption and estimate locomotor activity in tsetse flies, Glossina morsitans. *Physiological Entomology*, 2, 241-245.
- TERBLANCHE, J. S., CLUSELLA-TRULLAS, S., DEERE, J. A. & CHOWN, S. L. 2008. Thermal tolerance in a south-east African population of the tsetse fly Glossina pallidipes (Diptera, Glossinidae): implications for forecasting climate change impacts. *J Insect Physiol*, 54, 114-27.
- THOMPSON, J. W., MITCHELL, M., REES, R. B., SHERENI, W., SCHOENFELD, A. H. & WILSON, A. 1991. Studies on the efficacy of deltamethrin applied to cattle for the control of tsetse flies (Glossina spp.) in southern Africa. *Trop Anim Health Prod*, 23, 221-6.
- THOMSON, M. C. 1987. The effect on tsetse flies (Glossina spp.) of deltamethrin applied to cattle either as a spray or incorporated into ear-tags. *Tropical Pest Management*, 33, 329-335.
- TIRADOS, I., ESTERHUIZEN, J., KOVACIC, V., MANGWIRO, T. N. C., VALE, G. A., HASTINGS, I., SOLANO, P., LEHANE, M. J. & TORR, S. J. 2015. Tsetse Control and Gambian Sleeping Sickness; Implications for Control Strategy. *PLoS Negl Trop Dis*, 9, e0003822.
- TIRADOS, I., ESTERHUIZEN, J., RAYAISSE, J. B., DIARRASSOUBA, A., KABA, D., MPIANA, S., VALE, G. A., SOLANO, P., LEHANE, M. J. & TORR, S. J. 2011. How Do Tsetse Recognise Their Hosts? The Role of Shape in the Responses of Tsetse (*Glossina fuscipes* and *G. palpalis*) to Artificial Hosts. *PLoS Negl Trop Dis*, 5, e1226.
- TORR, S. J. 1988a. Behaviour of tsetse flies (Glossina) in host odour plumes in the field. *Physiological Entomology*, 13, 467-478.
- TORR, S. J. 1988b. The flight and landing of tsetse (Glossina) in response to components of host odour in the field. *Physiological Entomology*, 13, 453-465.
- TORR, S. J. 1989. The host-orientated behaviour of tsetse flies (Glossina): the interaction of visual and olfactory stimuli. *Physiological Entomology*, 14, 325-340.
- TORR, S. J., CHAMISA, A., VALE, G. A., LEHANE, M. J. & LINDH, J. M. 2011. Responses of tsetse flies, Glossina morsitans morsitans and Glossina pallidipes, to baits of various size. *Med Vet Entomol*, 25, 365-9.
- TORR, S. J. & HARGROVE, J. W. 1999. Behaviour of tsetse (Diptera: Glossinidae) during the hot season in Zimbabwe: the interaction of micro-climate and reproductive status. *Bulletin of Entomological Research*, 89, 365-379.
- TORR, S. J., HOLLOWAY, M. T. P. & VALE, G. A. 1992. Improved persistence of insecticide deposits on targets for controlling Glossina pallidipes (Diptera: Glossinidae). *Bulletin of Entomological Research*, 82, 525-533.
- TURNER, D. A. & INVEST, J. F. 1973. Laboratory analyses of vision in tsetse flies (Dipt., Glossinidae). *Bulletin of Entomological Research*, 62, 343-357.

- VALE, G. 1971. Artificial Refuges for tsetse flies ( *Glossina* spp.). *Bulletin of Entomological Research*, 61, 331-350.
- VALE, G. 1974a. The responses of tsetse flies (Diptera, Glossinidae) to mobile and stationary baits. *Bulletin of Entomological Research*, 64, 545-588.
- VALE, G. 1982. The improvement of traps for tsetse flies (Diptera: Glossinidae). *Bulletin of Entomological Research*, 72, 95-106.
- VALE, G. 1993a. Development of baits for tsetse flies (Diptera: Glossinidae) in Zimbabwe. *J Med Entomol*, 30, 831-42.
- VALE, G. 1993b. Visual responses of tsetse flies (Diptera: Glossinidae) to odour-baited targets. *Bulletin of Entomological Research*, 83, 277-289.
- VALE, G. A. 1969. Mobile attractants for tsetse flies, *Arnoldia*. 33, 1 - 6.
- VALE, G. A. 1974b. New field methods for studying the responses of tsetse flies (Diptera, Glossinidae) to hosts. *Bulletin of Entomological Research*, 64, 199-208.
- VALE, G. A. & HARGROVE, J. W. 1979. A method of studying the efficiency of traps for tsetse flies (Diptera: Glossinidae) and other insects. *Bulletin of Entomological Research*, 69, 183-193.
- VALE, G. A., HARGROVE, J. W., LEHANE, M. J., SOLANO, P. & TORR, S. J. 2015. Optimal Strategies for Controlling Riverine Tsetse Flies Using Targets: A Modelling Study. *PLoS Neglected Tropical Diseases*, 9, e0003615.
- VALE, G. A., LOVEMORE, D. F., FLINT, S. & COCKBILL, G. F. 1988. Odour-baited targets to control tsetse flies, *Glossina* spp. (Diptera: Glossinidae), in Zimbabwe. *Bulletin of Entomological Research*, 78, 31-49.
- VALE, G. A., MUTIKA, G. & LOVEMORE, D. F. 1999. Insecticide-treated cattle for controlling tsetse flies (Diptera: Glossinidae): some questions answered, many posed. *Bulletin of Entomological Research*, 89, 569-578.
- VAN DEN BOSSCHE, P. 1996. Laboratory bioassays of deltamethrin, topically applied, during the hunger cycle of male *Glossina tachinoides*. *Rev Elev Med Vet Pays Trop*, 49, 329-333.
- VANDERPLANK, F. L. 1941. Activity of *G. pallidipes* and the lunar cycle (Diptera). *Proceedings of the Royal Entomological Society of London. Series A*, 16, 61-64.
- VIJVERBERG, H. P. M. & VANDEN BERCKEN, J. 1990. Neurotoxicological Effects and the Mode of Action of Pyrethroid Insecticides. *Critical Reviews in Toxicology*, 21, 105-126.
- VREYSEN, M. J. 2001. Principles of area-wide integrated tsetse fly control using the sterile insect technique. *Med Trop (Mars)*, 61, 397-411.
- VREYSEN, M. J., ZHU, Z. R. & SALEH, K. M. 1998. Field responses of *Glossina austeni* to sticky panels on Unguja Island, Zanzibar. *Med Vet Entomol*, 12, 407-16.
- VREYSEN, M. J. B., KHAMIS, I. S. & VLOEDT, A. M. V. V. D. 1996. Evaluation of sticky panels to monitor populations of *Glossina austeni* (Diptera: Glossinidae) on Unguja island of Zanzibar. *Bulletin of Entomological Research*, 86, 289-296.
- VVITTEKIND, W. C. 1988. The landing response of tethered flying drosophila is induced at a critical object angle. *Journal of Experimental Biology*, 135, 491-493.
- WALLER, R. D. 1990. Tsetse fly in Western Narok, Kenya. *The Journal of African History*, 31, 81-101.
- WARRANT, E. J., MCINTYRE, P. D. & CAENEY, S. 1990. Maturation of optics and resolution in adult dung beetle superposition eyes. *Journal of Comparative Physiology A*, 167, 817-825.
- WHO 2014. Human African trypanosomiasis: the vector (tsetse fly). Webpage available: [http://www.who.int/trypanosomiasis\\_african/vector/en/](http://www.who.int/trypanosomiasis_african/vector/en/).
- WILLEMSE, L. 1991. A trial of odour baited targets to control the tsetse fly, *Glossina morsitans centralis* (Diptera: Glossinidae) in west Zambia. *Bulletin of Entomological Research*, 81, 351 - 357.
- WILLMER, P. G. 1994. Water relations of terrestrial arthropods. *Trends in Ecology & Evolution*, 10, 173.
- YORK, B., WIERSMA, C. A. & YANAGISAWA, K. 1972. Properties of the optokinetic motor fibres in the rock lobster: build-up, flipback, afterdischarge and memory, shown by their firing patterns. *J Exp Biol*, 57, 217-27.
- ZDÁREK, J. & DENLINGER, D. 1992. Ecdysis behavior in tsetse (Diptera: Glossinidae): Extrication from the puparium and expansion of the adult. *Journal of Insect Behavior*, 5, 657-668.