

## VOLUME GROWTH IN THE COMPONENT OF THE DEHN–SEIDEL TWIST

U. FRAUENFELDER AND F. SCHLENK

**Abstract.** We consider an entropy-type invariant which measures the polynomial volume growth of submanifolds under the iterates of a map, and we show that this invariant is at least 1 for every diffeomorphism in the symplectic isotopy class of the Dehn–Seidel twist.

### 1 Introduction and Main Results

The complexity of a compactly supported smooth diffeomorphism  $\varphi$  of a smooth manifold  $M$  can be measured in the following way: Fix a Riemannian metric  $g$  on  $M$ . For  $i \in \{1, \dots, \dim M\}$  denote by  $\Sigma_i$  the set of smooth embeddings  $\sigma$  of the cube  $Q^i = [0, 1]^i$  into  $M$ , and by  $\mu_g(\sigma)$  the volume of  $\sigma(Q^i) \subset M$  computed with respect to the measure on  $\sigma(Q^i)$  induced by  $g$ . Following [KT], we define for each  $i \in \{1, \dots, \dim M\}$  the  *$i$ -dimensional slow volume growth*  $s_i(\varphi) \in [0, \infty]$  by

$$s_i(\varphi) = \sup_{\sigma \in \Sigma_i} \liminf_{n \rightarrow \infty} \frac{\log \mu_g(\varphi^n(\sigma))}{\log n}.$$

This is the *polynomial* volume growth of the iterates of the most distorted smooth  $i$ -dimensional family of initial data. Since  $\varphi$  is compactly supported,  $s_i(\varphi)$  does not depend on the choice of  $g$ , and  $s_{\dim M}(\varphi) = 0$ .

Uniform lower bounds of  $s_1(\varphi)$  were first obtained in a beautiful paper of Polterovich [P1] for a class of symplectomorphisms  $\varphi \neq \text{id}$  in the identity component  $\text{Symp}_0(M)$  of the group of symplectomorphisms of a closed symplectic manifold with vanishing second homotopy group. E.g.  $s_1(\varphi) \geq 1$  for every symplectomorphism  $\varphi \in \text{Symp}_0(M, \omega) \setminus \{\text{id}\}$  of a closed oriented surface of genus  $\geq 2$ , and

$$s_1(\varphi) \geq \begin{cases} 1 & \text{if } d = 1, \\ \frac{1}{2} & \text{if } d \geq 2, \end{cases}$$

for every non-identical Hamiltonian diffeomorphism of the standard  $2d$ -dimensional torus. We endow the cotangent bundle  $T^*B$  over a closed base  $B$  with the canonical symplectic structure  $\omega = d\lambda$ , and denote by

$\text{Symp}_0^c(T^*B)$  the identity component of the group  $\text{Symp}^c(T^*B)$  of compactly supported  $C^\infty$ -smooth symplectomorphisms of  $(T^*B, d\lambda)$ . Combining a result in [FrS1] with the arguments in [P1], one finds

REMARK 1. *For every non-identical symplectomorphism  $\varphi \in \text{Symp}_0^c(T^*B)$  it holds true that  $s_1(\varphi) \geq 1$ .*

We refer to [FrS2] for a proof.

In this paper, we address a question of Polterovich in [P2] and study the slow volume growth of certain compactly supported symplectomorphisms outside the identity component. The spaces we shall consider are the cotangent bundles  $(T^*B, d\lambda)$  over compact rank one symmetric spaces (CROSSes, for short), and the diffeomorphisms are Dehn twist like symplectomorphisms. These maps were introduced to symplectic topology by Arnol'd [Ar] and Seidel [S2,3]. They play a prominent role in the study of the symplectic mapping class group of various symplectic manifolds, [KhS], [S1,2,3,8], and generalized Dehn twists along spheres can be used to detect symplectically knotted Lagrangian spheres, [S2,3], and (partly through their appearance in Seidel's long exact sequence in symplectic Floer homology, [S7]) are an important ingredient in attempts to prove Kontsevich's homological mirror symmetry conjecture, [KhS], [S4,5,6,9], [ST].

Let  $(B, g)$  be a CROSS of dimension  $d$ , i.e.  $B$  is a sphere  $S^d$ , a projective space  $\mathbb{R}P^d$ ,  $\mathbb{C}P^n$ ,  $\mathbb{H}P^n$ , or the exceptional symmetric space  $F_4/\text{Spin}_9$  diffeomorphic to the Cayley plane  $\mathbb{C}aP^2$ . All geodesics on  $(B, g)$  are embedded circles of equal length. We define  $\vartheta$  to be the compactly supported diffeomorphism of  $T^*B$  whose restriction to the cotangent bundle  $T^*\gamma \subset T^*B$  over any geodesic circle  $\gamma \subset B$  is the square of the ordinary left-handed Dehn twist along  $\gamma$  depicted in Figure 1. We call  $\vartheta$  a *twist*. A more analytic description of twists is given in section 2.3. It is known that twists are symplectic, and that the class of a twist generates an infinite cyclic subgroup of the mapping class group  $\pi_0(\text{Symp}^c(T^*B))$ , see [S3].

A  $d$ -dimensional submanifold  $L$  of  $T^*B$  is called *Lagrangian* if  $\omega$  vanishes on  $TL \times TL$ . Lagrangian submanifolds play a fundamental role in symplectic geometry. For each  $\varphi \in \text{Symp}^c(T^*B)$  we therefore also consider its *Lagrangian slow volume growth*

$$l(\varphi) = \sup_{\sigma \in \Lambda} \liminf_{n \rightarrow \infty} \frac{\log \mu_g(\varphi^n(\sigma))}{\log n}$$

where  $\Lambda$  is the set smooth embeddings  $\sigma : Q^d \hookrightarrow T^*B$  for which  $\sigma(Q^d)$  is a Lagrangian submanifold of  $T^*B$ . Of course,  $l(\varphi) \leq s_d(\varphi)$ . As we shall see

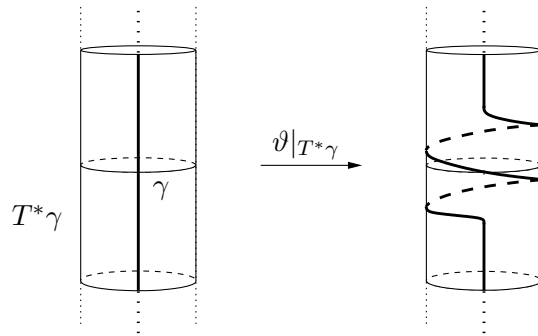

Figure 1: The map  $\vartheta|_{T^*\gamma}$ .

in section 2.3,  $s_i(\vartheta^m) = l(\vartheta^m) = 1$  for every  $i \in \{1, \dots, 2d - 1\}$  and every  $m \in \mathbb{Z} \setminus \{0\}$ .

**Theorem 1.** *Let  $B$  be a  $d$ -dimensional compact rank one symmetric space, and let  $\vartheta$  be the twist of  $T^*B$  described above. Assume that  $\varphi \in \text{Symp}^c(T^*B)$  is such that  $[\varphi] = [\vartheta^m] \in \pi_0(\text{Symp}^c(T^*B))$  for some  $m \in \mathbb{Z} \setminus \{0\}$ . Then  $s_d(\varphi) \geq l(\varphi) \geq 1$ .*

Theorem 1 is of particular interest if  $B$  is  $S^{2n}$  or  $\mathbb{C}P^n$ ,  $n \geq 1$ , since in these cases it is known that (a power of)  $\vartheta$  can be deformed to the identity through compactly supported diffeomorphisms, see [KaK], [S3] and Proposition 2.23 below. If  $B$  is  $S^{2n+1}$  or  $\mathbb{R}P^{2n+1}$ , then the variation homomorphism of  $\vartheta$  does not vanish, and so Theorem 1 already holds for homological reasons in this case, see Corollary 2.21 below. Twists can be defined on the cotangent bundle of any Riemannian manifold with periodic geodesic flow, and we shall prove Theorem 1 for all known such manifolds.

In the case that  $B$  is a sphere  $S^d$ , one can use the fact that all geodesics emanating from a point meet again in the antipode to see that the twist  $\vartheta$  admits a square root  $\tau \in \text{Symp}^c(T^*S^d)$ . For  $d = 1$ ,  $\tau$  is the ordinary left-handed Dehn twist along a circle, and for  $d \geq 2$  it is (the inverse of) the generalized Dehn twist thoroughly studied in [S1,2,3,8]. Given any great circle  $\gamma$  in  $S^d$ , the restriction of  $\tau$  to  $T^*\gamma \subset T^*S^d$  is the ordinary left-handed Dehn twist along  $\gamma$  depicted in Figure 2.

**COROLLARY 1.** *Let  $\tau$  be the (generalized) Dehn twist of  $T^*S^d$  described above, and assume that  $\varphi \in \text{Symp}^c(T^*S^d)$  is such that  $[\varphi] = [\tau^m] \in \pi_0(\text{Symp}^c(T^*S^d))$  for some  $m \in \mathbb{Z} \setminus \{0\}$ . Then  $s_d(\varphi) \geq l(\varphi) \geq 1$ .*

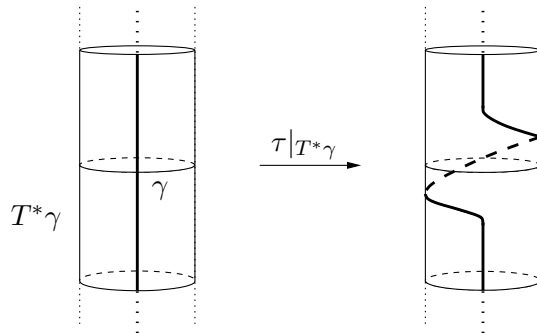
Figure 2: The map  $\tau|_{T^*\gamma}$ .

Since  $[\tau^2] = [\vartheta]$  has infinite order in  $\pi_0(\text{Symp}^c(T^*S^d))$ , so has  $[\tau]$ . In the case  $d = 2$  it is known that  $[\tau]$  generates  $\pi_0(\text{Symp}^c(T^*S^2))$ , see [S1,8]. Remark 1 and Corollary 1 thus give a nontrivial uniform lower bound of the slow volume growth

$$s(\varphi) = \max_i s_i(\varphi)$$

for each  $\varphi \in \text{Symp}^c(T^*S^2) \setminus \{\text{id}\}$ .

Following Shub [Sh], we consider a symplectomorphism  $\varphi \in \text{Symp}^c(T^*B)$  as a best diffeomorphism in its symplectic isotopy class if  $\varphi$  minimizes both  $s(\varphi)$  and  $l(\varphi)$ . We shall show that  $s_i(\tau^m) = l(\tau^m) = 1$  and  $s_i(\vartheta^m) = l(\vartheta^m) = 1$  for every  $i \in \{1, \dots, 2d - 1\}$  and every  $m \in \mathbb{Z} \setminus \{0\}$ . In view of Theorem 1 and Corollary 1, the twists  $\tau^m$  and  $\vartheta^m$  are then best diffeomorphisms in their symplectic isotopy classes.

**Acknowledgements.** This paper owes very much to Leonid Polterovich and Paul Seidel. We cordially thank both of them for their help. We are grateful to Yuri Chekanov, Anatole Katok, Nikolai Krylov, Janko Latschev and Dietmar Salamon for useful discussions. Much of this work was done during the stay of both authors at the Symplectic Topology Program at Tel Aviv University in Spring 2002 and during the second authors stay at FIM of ETH Zürich and at Leipzig University. We wish to thank these institutions for their kind hospitality, and the Swiss National Foundation and JSPS for their generous support.

## 2 Proofs

We shall first outline the proof of Theorem 1. We then describe the known Riemannian manifolds with periodic geodesic flow and define twists on such manifolds. We next prove Theorem 1 and Corollary 1, and notice that these results continue to hold for  $C^1$ -smooth symplectomorphisms. We finally study twists from a topological point of view.

**2.1 Idea of the proof of Theorem 1.** Consider the cotangent bundle  $T^*B$  over a CROSS  $(B, g)$ . We denote canonical coordinates on  $T^*B$  by  $(q, p)$  and denote by  $g^*$  the Riemannian metric on  $T^*B$  induced by  $g$ . For  $r > 0$  we abbreviate

$$T_r^*B = \{(q, p) \in T^*B \mid |p| \leq r\}.$$

To fix the ideas, we assume  $B = S^d$ , and that  $\varphi$  is isotopic to  $\vartheta$  through symplectomorphisms supported in  $T_1^*S^d$ . For  $x \in S^d$  we denote by  $D_x$  the 1-disc in  $T_x^*S^d$ . Consider first the case  $d = 1$ . We fix  $x$ . For a twist  $\vartheta$  as in Figure 1 and  $n \geq 1$ , the image  $\vartheta^n(D_x)$  wraps  $2n$  times around the base  $S^1$ . For topological reasons the same must hold for  $\varphi$ , and so

$$\mu_{g^*}(\varphi^n(D_x)) \geq 2n\mu_g(S^1).$$

In particular,  $s_1(\varphi) \geq 1$ . For odd-dimensional spheres, Theorem 1 follows from a similar argument. For even-dimensional spheres, however, Theorem 1 cannot hold for topological reasons, since then a power of  $\vartheta$  is isotopic to the identity through compactly supported diffeomorphisms. In order to find a symplectic argument, we rephrase the above proof for  $S^1$  in symplectic terms: For every  $y \neq x$  the Lagrangian submanifold  $\vartheta^n(D_x)$  intersects the Lagrangian submanifold  $D_y$  in  $2n$  points, and under symplectic deformations of  $\vartheta$  these  $2n$  Lagrangian intersections persist. This symplectic point of view generalizes to even-dimensional spheres: For a twist  $\vartheta$  on  $S^d$  as in Figure 1,  $n \geq 1$  and  $y \neq x$ , the Lagrangian submanifolds  $\vartheta^n(D_x)$  and  $D_y$  intersect in exactly  $2n$  points. We shall prove that the Lagrangian Floer homology of  $\vartheta^n(D_x)$  and  $D_y$  has rank  $2n$ . The isotopy invariance of Floer homology then implies that  $\varphi^n(D_x)$  and  $D_y$  must intersect in at least  $2n$  points. Since this holds true for every  $y \neq x$ , we conclude that

$$\mu_{g^*}(\varphi^n(D_x)) \geq 2n\mu_g(S^d).$$

In particular,  $s_d(\varphi) \geq l(\varphi) \geq 1$ .

**2.2  $P$ -manifolds.** Geodesics of a Riemannian manifold will always be parametrized by arc-length. A  $P$ -manifold is by definition a connected Riemannian manifold all of whose geodesics are periodic. It follows from

Wadsley's theorem that the geodesics of a  $P$ -manifold admit a common period, see [W] and [B, Lemma 7.11]. We normalize the Riemannian metric such that the minimal common period is 1. Every  $P$ -manifold is closed, and besides  $S^1$  every  $P$ -manifold has finite fundamental group, see [B, 7.37]. The main examples of  $P$ -manifolds are the CROSSes

$$S^d, \quad \mathbb{R}P^d, \quad \mathbb{C}P^n, \quad \mathbb{H}P^n, \quad \mathbb{C}aP^2$$

with their canonical Riemannian metrics suitably normalized. The simplest way of obtaining other  $P$ -manifolds is to look at Riemannian quotients of CROSSes. The main examples thus obtained are the spherical space forms  $S^{2n+1}/G$  where  $G$  is a finite subgroup of  $O(2n+2)$  acting freely on  $S^{2n+1}$ . These spaces are classified in [Wo], and examples are lens spaces, which correspond to cyclic  $G$ . According to [AM, p. 11–12] and [B, 7.17 (c)], the only other Riemannian quotients of CROSSes are the spaces  $\mathbb{C}P^{2n-1}/\mathbb{Z}_2$ ; here, the fixed point free involution on  $\mathbb{C}P^{2n-1}$  is induced by the involution

$$(z_1, z'_1, \dots, z_n, z'_n) \mapsto (\bar{z}'_1, -\bar{z}_1, \dots, \bar{z}'_n, -\bar{z}_n) \quad (1)$$

of  $\mathbb{C}^{2n}$ . Notice that  $\mathbb{C}P^1/\mathbb{Z}_2 = \mathbb{R}P^2$ . We shall thus assume  $n \geq 2$ . On spheres, there exist  $P$ -metrics which are not isometric to the round metric  $g_{\text{can}}$ . We say that a  $P$ -metric on  $S^d$  is a *Zoll metric* if it can be joined with  $g_{\text{can}}$  by a smooth path of  $P$ -metrics. All known  $P$ -metrics on  $S^d$  are Zoll metrics. For each  $d \geq 2$ , the Zoll metrics on  $S^d$  form an infinite dimensional space. For  $d \geq 3$ , the known Zoll metrics admit  $SO(d)$  as isometry group, but for  $d = 2$ , the set of Zoll metrics contains an open set all of whose elements have trivial isometry group. We refer to [B, Chapter 4] for more information about Zoll metrics.

CROSSes, their quotients and Zoll manifolds are the only known  $P$ -manifolds. It would be interesting to know whether this list is complete. As an aside, we mention that for the known  $P$ -manifolds all geodesics are simply closed. Whether this is so for all  $P$ -manifolds is unknown, [B, 7.73 (f'')], except for  $P$ -metrics on  $S^2$ , for which all geodesics are simply closed and of length 1, see [GrG].

An *SC-manifold* is a  $P$ -manifold all of whose closed geodesics are embedded circles of equal length. Among the known  $P$ -manifolds the *SC*-manifolds are the CROSSes and the known Zoll manifolds, see [B, 7.23]. For a geodesic  $\gamma : \mathbb{R} \rightarrow B$  of an *SC*-manifold  $(B, g)$  and  $t > 0$  we let  $\text{ind } \gamma(t)$  be the number of linearly independent Jacobi fields along  $\gamma(s)$ ,  $s \in [0, t]$ , which vanish at  $\gamma(0)$  and  $\gamma(t)$ . If  $\text{ind } \gamma(t) > 0$ , then  $\gamma(t)$  is said to be

conjugate to  $\gamma(0)$  along  $\gamma$ . The index of  $\gamma$  defined as

$$\text{ind } \gamma = \sum_{t \in ]0,1[} \text{ind } \gamma(t)$$

is a finite number. According to [B, 1.98 and 7.25], every geodesic on  $(B, g)$  has the same index, say  $k$ . We then call  $(B, g)$  an  $SC_k$ -manifold. The following result is well known, see [B, 3.35 and 3.70].

PROPOSITION 2.1. *For CROSSes, the indices of geodesics are as follows:*

$(B, g)$	$S^d$	$\mathbb{R}P^d$	$\mathbb{C}P^n$	$\mathbb{H}P^n$	$\mathbb{C}aP^2$
$k$	$d - 1$	0	1	3	7

**2.3 Twists.** Consider a  $P$ -manifold  $(B, g)$ . As before, we choose coordinates  $(q, p)$  on  $T^*B$ , and using  $g$  we identify the cotangent bundle  $T^*B$  with the tangent bundle  $TB$ . The Hamiltonian flow of the function  $\frac{1}{2}|p|^2$  corresponds to the geodesic flow on  $TB$ . For any smooth function  $f : [0, \infty[ \rightarrow [0, \infty[$  such that

$$f(r) = 0 \text{ for } r \text{ near } 0 \quad \text{and} \quad f'(r) = 1 \text{ for } r \geq 1, \tag{2}$$

we define the *twist*  $\vartheta_f$  as the time-1-map of the Hamiltonian flow generated by  $f(|p|)$ . Since  $(B, g)$  is a  $P$ -manifold,  $\vartheta_f$  is the identity on  $T^*B \setminus T_1^*B$ , and so  $\vartheta_f \in \text{Symp}^c(T^*B)$ .

PROPOSITION 2.2. (i) *The class  $[\vartheta_f] \in \pi_0(\text{Symp}^c(T^*B))$  does not depend on the choice of  $f$ .*

(ii)  *$s_i(\vartheta_f^m) = l(\vartheta_f^m) = 1$  for every  $i \in \{1, \dots, 2d - 1\}$ , every  $m \in \mathbb{Z} \setminus \{0\}$  and every  $f$ .*

*Proof.* (i) Let  $f_i : [0, 1] \rightarrow [0, 1]$ ,  $i = 1, 2$ , be two functions as in (2). Then the functions  $f_s = (1 - s)f_1 + sf_2$ ,  $s \in [0, 1]$ , are also of this form, and  $s \mapsto \vartheta_{f_s}$  is an isotopy in  $\text{Symp}^c(T^*B)$  joining  $\vartheta_{f_1}$  with  $\vartheta_{f_2}$ .

(ii) Without loss of generality we assume  $m = 1$ . Let  $\vartheta^t$  be the Hamiltonian flow of  $f(|p|)$ . Then  $\vartheta_f = \vartheta^1$ . For each  $r > 0$  the hypersurface  $S_r = \partial T_r^*B$  is invariant under  $\vartheta^t$ . We denote by  $\vartheta_r^t$  the restriction of  $\vartheta^t$  to  $S_r$ . As before, we endow  $T^*B$  with the Riemannian metric  $g^*$ . For  $x \in S_r$  let  $\|d\vartheta_r^t(x)\|$  be the operator norm of the differential of  $\vartheta_r^t$  at  $x$  induced by  $g^*$ . Since  $\vartheta_1^t$  is 1-periodic, we find  $C < \infty$  such that  $\|d\vartheta_1^t(x)\| \leq C$  for all  $t$  and all  $x \in S_1$ . Since

$$\vartheta_r^t(x) = r\vartheta_1^{f'(r)t} \left( \frac{x}{r} \right)$$

for all  $t \in \mathbb{R}$ ,  $r > 0$  and  $x \in S_r$ , we conclude that

$$\|d\vartheta_r^t(x)\| = \left\| d\vartheta_1^{f'(r)t} \left(\frac{x}{r}\right) \right\| \leq C \tag{3}$$

for all  $t \in \mathbb{R}$ ,  $r > 0$  and  $x \in S_r$ . We next fix  $(q, p) \in T^*B \setminus B$  and consider the line  $F_p = \mathbb{R}p \subset T_q^*B$  orthogonal to  $S_{|p|}$  through  $(q, p)$ . We denote by  $\vartheta_p^t$  the restriction of  $\vartheta^t$  to  $F_p$ . Let  $\gamma$  be the geodesic on  $B$  with  $\gamma(0) = q$  and  $\dot{\gamma}(0) = p/|p|$ . Then  $\vartheta_p^t(F_p) \subset T^*\gamma$  for all  $t$ . As a parametrized curve,  $\gamma$  is isometric to the circle  $S^1$  of length 1, and so  $T^*\gamma \setminus \gamma$  is isometric to  $T^*S^1 \setminus S^1$ . We thus find

$$\|d\vartheta_p^t(q, p)\| = \sqrt{(f''(|p|)t)^2 + 1} \leq C'(t + 1) \tag{4}$$

for all  $t \geq 0$  and  $(q, p) \in T^*B$  and some constant  $C' < \infty$ . The estimates (3) and (4) show that for any  $i$ -cube  $\sigma : Q^i \hookrightarrow T^*B$ ,

$$\mu_{g^*}(\vartheta_f^n(\sigma)) \leq C^{i-1}C'(n + 1)$$

for all  $n \geq 1$ , and so  $s_i(\vartheta_f) \leq 1$  for all  $i$ .

We are left with showing  $s_i(\vartheta_f) \geq 1$  for  $i \in \{1, \dots, 2d - 1\}$ . Fix  $q \in B$ , choose an orthonormal basis  $\{e_1, \dots, e_d\}$  of  $T_q^*B$ , and let  $R$  be such that  $f([0, 1]) \subset [0, R]$ . For  $j \in \{1, \dots, d\}$  we let  $E^j$  be the subspace of  $T_q^*B$  generated by  $\{e_1, \dots, e_j\}$ , and we set  $E_R^j = E^j \cap T_R^*B$ . We first assume  $i \in \{1, \dots, d\}$ . We then choose  $\sigma : Q^i \hookrightarrow E^i$  such that  $E_R^i \subset \sigma(Q^i)$ . The set  $\pi(\vartheta_f(\sigma))$  consists of a smooth  $(i - 1)$ -dimensional family of geodesics in  $B$ . Its  $i$ -dimensional measure  $\mu_g(\pi(\vartheta_f(\sigma)))$  with respect to  $g$  thus exists and is positive. Moreover,  $\pi(\vartheta_f^n(\sigma)) = \pi(\vartheta_f(\sigma))$  for all  $n \geq 1$ , and every point in  $\pi(\vartheta_f^n(\sigma))$  has at least  $2n$  preimages in  $\vartheta_f^n(\sigma)$ . Since  $\pi : (T^*B, g^*) \rightarrow (B, g)$  is a Riemannian submersion, we conclude that

$$\mu_{g^*}(\vartheta_f^n(\sigma)) \geq 2n\mu_g(\pi(\vartheta_f^n(\sigma))),$$

and so  $s_i(\vartheta_f) \geq 1$ .

Since the fibre  $T_q^*B$  is a Lagrangian submanifold of  $T^*B$ , we have shown that  $s(\vartheta_f) = l(\vartheta_f) = 1$ . We shall therefore only sketch the proof of the remaining inequalities  $s_i(\vartheta_f) \geq 1$ ,  $i \in \{d + 1, \dots, 2d - 1\}$ . For such an  $i$  we choose a small  $\epsilon > 0$ , set  $B_i = \exp_q E_\epsilon^{i-d}$ , and choose  $\sigma : Q^i \hookrightarrow T^*B_i$  such that  $T_R^*B_i \subset \sigma(Q^i)$ . Then there is a constant  $c > 0$  such that

$$\mu_{g^*}(\vartheta_f^n(\sigma)) \geq cn \quad \text{for all } n \geq 1. \tag{5}$$

This is so because  $\vartheta_f$  restricts to a symplectomorphism on the  $i - d$  cylinders  $T^*\gamma_j$  over the geodesics  $\gamma_j$  with  $\gamma_j(0) = q$  and  $\dot{\gamma}(0) = e_j$ , and – as we have seen above – grows linearly on the  $(2d - i)$ -dimensional remaining factor in the fibre. An explicit proof of (5) can be given by computing the

differential  $d\vartheta_f(q, p)$  with respect to suitable orthonormal bases of  $T_{(q,p)}T^*B$  and  $T_{\vartheta_f(q,p)}T^*B$ .  $\square$

Let  $\tau \in \text{Symp}^c(T^*S^d)$  be a generalized Dehn twist as defined in Figure 2; for an analytic definition (of its inverse) we refer to [S3, 5a]. Then  $\tau^2$  is a twist  $\vartheta_f$ . Proposition 2.2 (ii) and the argument given in 2.7 below thus show that  $s_i(\tau^m) = l(\tau^m) = 1$  for every  $i \in \{1, \dots, 2d - 1\}$  and every  $m \in \mathbb{Z} \setminus \{0\}$ .

Theorem 1 is a special case of the following theorem, which is the main result of this paper.

**Theorem 2.3.** *Let  $(B, g)$  be a  $d$ -dimensional  $P$ -manifold. If  $d \geq 3$ , assume that  $(B, g)$  is an  $SC_k$ -manifold or a Riemannian quotient of such a manifold, and if  $d \geq 3$  and  $k = 1$ , assume that  $(B, g)$  is  $\mathbb{C}P^n$  or  $\mathbb{C}P^{2n-1}/\mathbb{Z}_2$ . Let  $\vartheta$  be a twist on  $T^*B$ . If  $\varphi \in \text{Symp}^c(T^*B)$  is such that  $[\varphi] = [\vartheta^m] \in \pi_0(\text{Symp}^c(T^*B))$  for some  $m \in \mathbb{Z} \setminus \{0\}$ , then  $s_d(\varphi) \geq l(\varphi) \geq 1$ .*

REMARKS 2.4. 1. (i) Theorem 2.3 covers all known  $P$ -manifolds. Indeed, it covers CROSSes and their Riemannian quotients. Moreover, if  $(S^d, g)$  is a Zoll manifold, we choose a smooth family  $g_t$ ,  $t \in [0, 1]$ , of  $P$ -metrics on  $S^d$  with  $g_0 = g_{\text{can}}$  and  $g_1 = g$ . The induced isotopy  $\vartheta_t$  of twists shows that  $[\vartheta_0] = [\vartheta_1]$  in  $\pi_0(\text{Symp}^c(T^*S^d))$ , and so the conclusion of Theorem 2.3 for Zoll manifolds follows from the one for  $(S^d, g_{\text{can}})$ .

(ii) The following result suggests that Theorem 2.3 covers all  $SC$ -manifolds: If  $(B, g)$  is an  $SC_1$ -manifold, then  $B$  has the homotopy type of  $\mathbb{C}P^n$ , see [B, 7.23].

2. (i) We recall from [S1,8] that  $\pi_0(\text{Symp}^c(T^*S^2)) = \mathbb{Z}$  is generated by the class  $[\tau]$  of a generalized Dehn twist.

(ii) For  $S^d$ ,  $d \geq 3$ ,  $[\tau]^2 = [\vartheta]$  and Theorem 2.3 imply that  $[\tau]$  generates an infinite cyclic subgroup of  $\pi_0(\text{Symp}^c(T^*S^d))$ , and for those  $P$ -manifolds  $(B, g)$  covered by Theorem 2.3 which are not diffeomorphic to a sphere, Theorem 2.3 implies that  $[\vartheta]$  generates an infinite cyclic subgroup of  $\pi_0(\text{Symp}^c(T^*B))$ . This was proved in [S3, Corollary 4.5] for all  $P$ -manifolds. (It is assumed in [S3] that  $H^1(B; \mathbb{R}) = 0$ . Besides for  $B = S^1$  this is, however, guaranteed by the Bott–Samelson theorem [B, Theorem 7.37].) It would be interesting to know whether there are other elements in these symplectic mapping class groups.  $\square$

Theorem 2.3 is proved in the next two sections.

**2.4 Lagrangian Floer homology.** Floer homology for Lagrangian submanifolds was invented by Floer in a series of seminal papers, [F1,2,3,4], and more general versions have been developed meanwhile, [FuOOO], [O1]. In this section we first follow [KhS] and define Lagrangian Floer homology for certain pairs of Lagrangian submanifolds with boundary in an exact compact convex symplectic manifold. We then compute this Floer homology in the special case that the pair consists of a fibre and the image of another fibre under an iterated twist on the unit coball bundle over a (known)  $SC$ -manifold.

**2.4.1 Lagrangian Floer homology on convex symplectic manifolds.** We consider an exact compact connected symplectic manifold  $(M, \omega)$  with boundary  $\partial M$  and two compact Lagrangian submanifolds  $L_0$  and  $L_1$  of  $M$  meeting the following hypotheses:

- (H1)  $L_0$  and  $L_1$  intersect transversally;
- (H2)  $L_0 \cap L_1 \cap \partial M = \emptyset$ ;
- (H3)  $H^1(L_j; \mathbb{R}) = 0$  for  $j = 0, 1$ .

We also assume that there exists a Liouville vector field  $X$  (i.e.  $\mathcal{L}_X \omega = d\nu_X \omega = \omega$ ) which is defined on a neighbourhood  $U$  of  $\partial M$  and is everywhere transverse to  $\partial M$ , pointing outwards, such that

- (H4)  $X(x) \in T_x L_j$  for all  $x \in L_j \cap U$ ,  $j = 0, 1$ .

Let  $\varphi_r$  be the local semiflow of  $X$  defined near  $\partial M$ . Since  $\partial M$  is compact, we find  $\epsilon > 0$  such that  $\varphi_r(x)$  is defined for  $x \in \partial M$  and  $r \in [-\epsilon, 0]$ . For these  $r$  we set

$$U_r = \bigcup_{r \leq r' \leq 0} \varphi_{r'}(\partial M).$$

In view of (H2) there exists  $\epsilon' \in ]0, \epsilon[$  such that for  $V = U_{\epsilon'}$  we have

$$V \cap L_0 \cap L_1 = \emptyset. \quad (6)$$

An almost complex structure  $J$  on  $(M, \omega)$  is called  $\omega$ -compatible if  $\omega \circ (\text{id} \times J)$  is a Riemannian metric on  $M$ . Following [BiPS], [CFH], [V], we consider the space  $\mathcal{J}$  of smooth families  $\mathbf{J} = \{J_t\}$ ,  $t \in [0, 1]$ , of smooth  $\omega$ -compatible almost complex structures on  $M$  such that  $J_t(x) = J(x)$  does not depend on  $t$  for  $x \in V$  and such that

- (J1)  $\omega(X(x), J(x)v) = 0$ ,  $x \in \partial M$ ,  $v \in T_x \partial M$ ;
- (J2)  $\omega(X(x), J(x)X(x)) = 1$ ,  $x \in \partial M$ ;
- (J3)  $d\varphi_r(x)J(x) = J(\varphi_r(x))d\varphi_r(x)$ ,  $x \in \partial M$ ,  $r \in [-\epsilon', 0]$ .

For later use we examine conditions (J1) and (J2) more closely. The contact structure  $\xi$  on  $\partial M$  is defined as

$$\xi = \{v \in T\partial M \mid \omega(X, v) = 0\}, \tag{7}$$

and the Reeb vector field  $R$  on  $\partial M$  is defined by

$$\omega(X, R) = 1 \quad \text{and} \quad \omega(R, v) = 0 \quad \text{for all } v \in T\partial M. \tag{8}$$

LEMMA 2.5. *Conditions (J1) and (J2) are equivalent to*

$$J\xi = \xi \quad \text{and} \quad JX = R.$$

The proof follows from definitions and the  $J$ -invariance of  $\omega$ . It follows from Lemma 2.5 that the set  $\mathcal{J}$  is nonempty and connected, see [CFH]. Let

$$S = \{z = s + it \in \mathbb{C} \mid s \in \mathbb{R}, t \in [0, 1]\}$$

be the strip. The energy of  $u \in C^\infty(S, M)$  is defined as

$$E(u) = \int_S u^* \omega.$$

For  $u \in C^\infty(S, M)$  consider Floer’s equation

$$\begin{cases} \partial_s u + J_t(u) \partial_t u = 0, \\ u(s, j) \in L_j \quad \text{for } j \in \{0, 1\}, \\ E(u) < \infty. \end{cases} \tag{9}$$

Notice that for a solution  $u$  of (9),

$$E(u) = \int_S \|\partial_s u\|^2 = \frac{1}{2} \int_S \|\partial_s u\|^2 + \|\partial_t u\|^2$$

is the energy of  $u$  associated with respect to any Riemannian metric defined via an  $\omega$ -compatible  $J$ . It follows from (H1) that for every solution  $u$  of (9) there exist points  $c_-, c_+ \in L_0 \cap L_1$  such that  $\lim_{s \rightarrow \pm\infty} u(s, t) = c_\pm$  uniformly in  $t$ , cf. [S, Proposition 1.21]. The following lemma taken from [EHS], [KhS] shows that the images of solutions of (9) uniformly stay away from  $\partial M$ .

LEMMA 2.6. *Let  $u$  be a finite energy solution of (9). Then*

$$u(S) \cap V = \emptyset.$$

*Proof.* Define  $f : V \rightarrow \mathbb{R}$  by  $f(\varphi_r(x)) = e^r$ , where  $x \in \partial M$  and  $r \in [-\epsilon', 0]$ . Using (J1), (J2), (J3) we find that the gradient  $\nabla f$  with respect to each metric  $\omega \circ (\text{id} \times J_t)$  is  $X$ ; for the function

$$F : \Omega = u^{-1}(V) \rightarrow \mathbb{R}, \quad (s, t) = z \mapsto F(z) = f \circ u(z),$$

one therefore computes  $\Delta F = \langle \partial_s u, \partial_s u \rangle$ , see e.g. [FrS1], so that  $F$  is subharmonic. It follows that  $F$  does not attain a strict maximum on the interior of  $\Omega$ . In order to see that this holds on  $\Omega$ , fix a point  $z \in \partial S$ . We

first assume  $z = (s, 0)$ , and claim that the function  $F$  satisfies the Neumann boundary condition at  $z$ ,

$$\partial_t F(z) = 0.$$

Indeed, we compute at  $z$  that

$$\begin{aligned} \partial_t F &= df(\partial_t u) = \langle \nabla f, \partial_t u \rangle = \langle X, \partial_t u \rangle \\ &= \omega(X, J\partial_t u) = -\omega(X, \partial_s u) = 0, \end{aligned}$$

where in the last step we have used that  $X \in TL_0$  by (H4) and  $\partial_s u \in TL_0$  by (9). Let now  $\tau$  be the reflection  $(s, t) \mapsto (s, -t)$ , set  $\widehat{\Omega} = \Omega \cup \tau(\Omega)$ , and let  $\widehat{F}$  be the extension of  $F$  to  $\widehat{\Omega}$  satisfying  $\widehat{F}(s, -t) = F(s, t)$ . Since  $\partial_t F = 0$  along  $\{t = 0\}$ , the continuous function  $\widehat{F}$  is weakly subharmonic, and hence cannot have a strict maximum on  $\widehat{\Omega}$ . Repeating this argument for  $z = (s, 1) \in \Omega$ , we see that the same holds for  $F$  on  $\Omega$ , and so either  $u(S) \cap V = \emptyset$ , or  $F$  is locally constant. In the latter case,  $\Omega = S$ , so that

$$\lim_{s \rightarrow \infty} u(s, t) = c_+ \in L_0 \cap V,$$

which is impossible in view of (6). □

We endow  $\mathcal{J}$  with the  $C^\infty$ -topology. Recall that a subset of  $\mathcal{J}$  is *generic* if it is contained in a countable intersection of open and dense subsets. For  $\mathbf{J} \in \mathcal{J}$  let  $\mathcal{M}(\mathbf{J})$  be the space of solutions of (9). The following proposition is proved in [FHS], [O2].

**PROPOSITION 2.7.** *There exists a generic subset  $\mathcal{J}_{\text{reg}}$  of  $\mathcal{J}$  such that for each  $\mathbf{J} \in \mathcal{J}_{\text{reg}}$  the moduli space  $\mathcal{M}(\mathbf{J})$  is a smooth finite dimensional manifold.*

Under hypotheses (H1)–(H4), the ungraded Floer homology  $HF(M, L_0, L_1)$  can be defined. In order to prove Theorem 2.3 we must compute the rank of this homology, and to this end it will be crucial to endow it with a relative  $\mathbb{Z}$ -grading. We therefore impose a final hypothesis. For  $c_-, c_+ \in L_0 \cap L_1$  consider the space  $\mathcal{B}(c_-, c_+)$  of smooth maps  $u : S \rightarrow M$  which satisfy  $u(s, j) \in L_j$ ,  $j = 0, 1$ , and  $\lim_{s \rightarrow \pm\infty} u(s, t) = c_\pm$  uniformly in  $t$  in the  $C^\infty$ -topology. For  $u \in \mathcal{B}(c_-, c_+)$  we consider the Banach spaces

$$W_u^{1,p} = \{ \xi \in W^{1,p}(S, u^*TM) \mid \xi(s, j) \in T_{u(s,j)}L_j, j = 0, 1 \}$$

and  $L_u^p = L^p(S, u^*TM)$ . Linearizing Floer’s equation for  $\mathbf{J} \in \mathcal{J}$  we obtain the linear operator  $D_{u,\mathbf{J}} : W_u^{1,p} \rightarrow L_u^p$  given by

$$D_u \xi = \nabla_s \xi + J_t(u) \nabla_t \xi + \nabla_\xi J_t(u) \partial_t u.$$

This operator is Fredholm, cf. [S, Theorem 2.2], and we denote by  $I(u)$  its Fredholm index. If  $\mathbf{J} \in \mathcal{J}_{\text{reg}}$  and  $u$  solves Floer’s equation, then  $I(u)$  is the

dimension of the manifold

$$\mathcal{M}(c_-, c_+; \mathbf{J}) = \mathcal{M}(\mathbf{J}) \cap \mathcal{B}(c_-, c_+).$$

We can now formulate our fifth hypothesis.

- (H5) The Fredholm index  $I(u)$  of  $u \in \mathcal{B}(c_-, c_+)$  only depends on  $c_-$  and  $c_+$ .

Using (H5) and the gluing theorem for Fredholm indices one sees that there exists an index function

$$\text{ind} : L_0 \cap L_1 \rightarrow \mathbb{Z}$$

such that  $I(u) = \text{ind } c_- - \text{ind } c_+$  for every  $u \in \mathcal{B}(c_-, c_+)$ . Such an index function is unique up to addition of an integer, and hence defines a relative grading on  $L_0 \cap L_1$ . Moreover,

$$\dim \mathcal{M}(c_-, c_+; \mathbf{J}) = \text{ind } c_- - \text{ind } c_+.$$

For  $k \in \mathbb{Z}$  let  $CF_k(M, L_0, L_1)$  be the  $\mathbb{Z}_2$ -vector space generated by the points  $c \in L_0 \cap L_1$  with  $\text{ind } c = k$ . In view of (H1), the rank of  $CF_k(M, L_0, L_1)$  is finite. In order to define a chain map on  $CF_*(M, L_0, L_1)$  we need the following:

LEMMA 2.8. For  $u \in \mathcal{M}(c_-, c_+; \mathbf{J})$  the energy  $E(u)$  only depends on  $c_-$  and  $c_+$ .

*Proof.* We have  $E(u) = \int_u d\lambda = \int_{\partial u} \lambda = \int_{u(\mathbb{R}, 0)} \lambda - \int_{u(\mathbb{R}, 1)} \lambda$  for any primitive  $\lambda$  of  $\omega$ . Since  $d\lambda|_{L_j} = 0$  and  $H^1(L_j; \mathbb{R}) = 0$ , we find smooth functions  $f_i$  on  $L_j$  such that  $\lambda|_{L_j} = df_j$  for  $j = 0, 1$ . Therefore,  $E(u) = f_0(c_+) - f_0(c_-) - f_1(c_+) + f_1(c_-)$ .  $\square$

The group  $\mathbb{R}$  acts on  $\mathcal{M}(c_-, c_+; \mathbf{J})$  by time-shift. In view of Lemma 2.6 the elements of  $\mathcal{M}(c_-, c_+; \mathbf{J})$  uniformly stay away from the boundary  $\partial M$ , and by Lemma 2.8 and (H1), their energy is uniformly bounded. Moreover,  $[\omega]|_{\pi_2(M)} = 0$  and  $[\omega]|_{\pi_2(M, L_j)} = 0$  since  $\omega$  is exact and by (H3), so that when taking limits in  $\mathcal{M}(c_-, c_+; \mathbf{J})$  there is no bubbling off of  $\mathbf{J}$ -holomorphic spheres or discs. The Floer–Gromov compactness theorem thus implies that the quotient  $\mathcal{M}(c_-, c_+; \mathbf{J})/\mathbb{R}$  is compact. In particular, if  $\text{ind } c_- - \text{ind } c_+ = 1$ , then  $\mathcal{M}(c_-, c_+; \mathbf{J})/\mathbb{R}$  is a finite set, and we then set

$$n(c_-, c_+; \mathbf{J}) = \#\{\mathcal{M}(c_-, c_+; \mathbf{J})/\mathbb{R}\} \pmod{2}.$$

For  $k \in \mathbb{Z}$  define the Floer boundary operator  $\partial_k(\mathbf{J}) : CF_k \rightarrow CF_{k-1}$  as the linear extension of

$$\partial_k(\mathbf{J})c = \sum_{\substack{c' \in L_0 \cap L_1 \\ i(c')=k-1}} n(c', c)c'.$$

Using the compactness of the 0- and 1-dimensional parts of  $\mathcal{M}(\mathbf{J})/\mathbb{R}$  one shows by gluing that  $\partial_{k-1}(\mathbf{J}) \circ \partial_k(\mathbf{J}) = 0$  for each  $k$ , see [F2], [Sc]. The complex  $(CF_*(M, L_0, L_1; \mathbf{J}), \partial_*(\mathbf{J}))$  is called the Floer chain complex. A continuation argument together with Lemma 2.6 shows that its homology

$$HF_k(M, L_0, L_1; \mathbf{J}) = \frac{\ker \partial_k(\mathbf{J})}{\text{im } \partial_{k+1}(\mathbf{J})}$$

is a graded  $\mathbb{Z}_2$ -vector space which does not depend on  $\mathbf{J} \in \mathcal{J}_{\text{reg}}$ , see again [F2], [Sc], and so we can define the Lagrangian Floer homology of the triple  $(M, L_0, L_1)$  by

$$HF_*(M, L_0, L_1) = HF_*(M, L_0, L_1; \mathbf{J})$$

for any  $\mathbf{J} \in \mathcal{J}_{\text{reg}}$ . We denote by  $\text{Ham}^c(M)$  the group of Hamiltonian diffeomorphisms generated by time-dependent Hamiltonian functions  $H : [0, 1] \times M \rightarrow \mathbb{R}$  whose support is contained in  $[0, 1] \times (M \setminus \partial M)$ . The usual continuation argument also implies

PROPOSITION 2.9. *For any  $\varphi \in \text{Ham}^c(M)$  we have  $HF_*(M, \varphi(L_0), L_1) = HF_*(M, L_0, L_1)$  as relatively graded  $\mathbb{Z}_2$ -vector spaces.*

**2.5 Computation of  $HF_*(\vartheta^m(D_x), D_y)$ .** We consider a  $d$ -dimensional  $SC_k$ -manifold  $(B, g)$ . Using the Riemannian metric  $g$  we identify  $T_1^*B$  with the unit ball bundle  $T_1B$ , and for  $x \in B$  we set  $D_x = T_xB \cap T_1B$ . We choose  $x \in B$ , denote by  $\rho$  the injectivity radius at  $x$ , and define the non-empty open subset  $W$  of  $B$  by

$$W = \exp_x \{v \in T_xB \mid 0 < |v| < \rho\}.$$

Let  $f : [0, \infty[ \rightarrow [0, \infty[$  be a smooth function as in (2). More precisely, we choose  $f$  such that

$$f(r) = 0 \text{ if } r \in [0, \frac{1}{3}] , \quad f'(r) = 1 \text{ if } r \geq \frac{2}{3}, \quad f''(r) > 0 \text{ if } r \in ]\frac{1}{3}, \frac{2}{3}[.$$

Fix  $m \in \mathbb{Z} \setminus \{0\}$ . For notational convenience we assume  $m \geq 1$ . The symplectomorphism  $\vartheta^m = \vartheta_f^m \in \text{Symp}^c(T^*B)$  is generated by  $mf(|p|)$ . Choose now  $y \in W$ . Since  $(B, g)$  is an  $SC$ -manifold, there is only one geodesic circle  $\gamma$  containing both  $x$  and  $y$ , see [B, 7.27]. This and our choice of  $f$  imply that the two Lagrangian submanifolds

$$L_0 = \vartheta^m(D_x) \quad \text{and} \quad L_1 = D_y$$

intersect transversely in exactly  $2m$  points over  $\gamma$  and in particular meet hypothesis (H1); moreover,  $\vartheta^m$  is the identity on  $U = T_1^*B \setminus T_{2/3}^*B$ , so that  $L_0 \cap L_1 \cap U = \emptyset$  and (H2) is met. Since  $L_0$  and  $L_1$  are simply connected, (H3) is also met, and

$$X = X(q, p) = \sum_{i=1}^d p_i \frac{\partial}{\partial p_i} \tag{10}$$

is a Liouville vector field defined on all of  $T_1^*B$  which is transverse to  $\partial T_1^*B$ , pointing outwards, and  $X(x) \in T_x L_j$  for all  $x \in L_j \cap U$ ,  $j = 0, 1$ , verifying (H4). Finally, hypothesis (H5) follows from the general theory of Maslov indices, which applies in view of (H3) and the fact that the first Chern class  $c_1$  of  $(T_1^*B, d\lambda)$  vanishes, see [S2].

We now follow [S2] and describe the natural grading on  $HF(T_1^*B, L_0, L_1)$ . Let  $\delta$  be the distance of  $y$  from  $x$ ; then  $0 < \delta < \rho < 1/2$ . For  $i \in \mathbb{N}_m = \{0, 1, \dots, m - 1\}$  we set

$$\tau_i^+ = i + \delta \quad \text{and} \quad \tau_i^- = i + 1 - \delta$$

and define  $r_i^\pm \in ]\frac{1}{3}, \frac{2}{3}[$  by  $mf'(r_i^\pm) = \tau_i^\pm$ . The  $2m$  points in  $L_0 \cap L_1$  are then given by

$$c_i^\pm = \vartheta^m(r_i^\pm \dot{\gamma}^\pm(0)) = r_i^\pm \dot{\gamma}^\pm(\delta)$$

where  $\gamma^+ : \mathbb{R} \rightarrow B$  is the geodesic with  $\gamma^+(0) = x$  and  $\gamma(\delta) = y$  and  $\gamma^-(t) = \gamma^+(-t)$  is the opposite geodesic, cf. Figure 3.

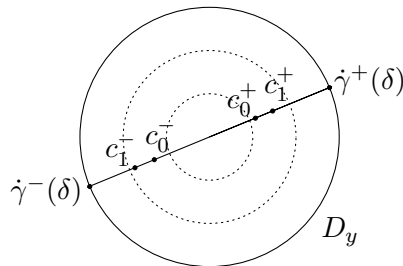

Figure 3: The points  $c_i^\pm \in L_0 \cap L_1$  for  $m = 2$ .

Define the index function  $\text{ind} : L_0 \cap L_1 \rightarrow \mathbb{Z}$  by

$$\text{ind } c_i^\pm = \sum_{0 < t < \tau_i^\pm} \text{ind } \dot{\gamma}^\pm(t), \quad i \in \mathbb{N}_m.$$

It is shown in [S2] that for  $u \in \mathcal{B}(c_-, c_+)$  the Fredholm index  $I(u)$  is  $\text{ind } c_- - \text{ind } c_+$ , so that  $\text{ind}$  indeed serves as an index function. Using this grading, we abbreviate

$$CF_*(B, m) = CF_*(T_1^*B, L_0, L_1) \quad \text{and} \quad HF_*(B, m) = HF_*(T_1^*B, L_0, L_1).$$

Our next goal is to compute the Floer chain groups  $CF_*(B, m)$ .

PROPOSITION 2.10. For a  $d$ -dimensional  $SC_k$ -manifold  $(B, g)$  and  $i \in \mathbb{N}_m$ ,

$$\text{ind } c_i^+ = i(k + d - 1) \quad \text{and} \quad \text{ind } c_i^- = i(k + d - 1) + k.$$

*Proof.* We start with a general lemma.

LEMMA 2.11. *Let  $\gamma : \mathbb{R} \rightarrow B$  be a geodesic of a  $P$ -manifold  $(B, g)$ , and let  $J : \mathbb{R} \rightarrow B$  be a Jacobi field along  $\gamma$  such that  $J(0) = 0$ . If  $J(t) = 0$ , then  $J(t + n) = 0$  for all  $n \in \mathbb{Z}$ .*

*Proof.* We can assume that  $J'(t) \neq 0$  since otherwise  $J \equiv 0$ . Fix  $n \in \mathbb{Z}$ . Since  $(B, g)$  is a  $P$ -manifold,  $\gamma(t + n)$  is conjugate to  $\gamma(t)$  with multiplicity  $d - 1$ . Since this is the maximal possible multiplicity of a conjugate point, and since  $J(t) = 0$  and  $J'(t) \neq 0$ ,  $J$  must be a Jacobi field conjugating  $J(t)$  and  $J(t + n)$ , i.e.  $J(t + n) = 0$ .  $\square$

By our choice of  $y$ , the point  $y$  is not conjugate to  $x$  along  $\gamma^+ : [0, \delta] \rightarrow B$ , and so  $\text{ind } c_0^+ = 0$ . Since  $(B, g)$  is a  $d$ -dimensional  $SC_k$ -manifold, Lemma 2.11 now implies  $\text{ind } c_i^+ = i(k + d - 1)$  for all  $i \in \mathbb{N}_m$ . The choice of  $y$  and Lemma 2.11 imply that  $\text{ind } c_0^- = k$ , and now Lemma 2.11 implies  $\text{ind } c_i^- = i(k + d - 1) + k$  for all  $i \in \mathbb{N}_m$ .  $\square$

In view of Proposition 2.10 we find

COROLLARY 2.12. *Let  $(B, g)$  be a  $d$ -dimensional  $SC_k$ -manifold.*

*If  $k \geq 1$ ,*

$$CF_i(B, m) = \begin{cases} \mathbb{Z}_2 & i \in (k + d - 1)\mathbb{N}_m \cup ((k + d - 1)\mathbb{N}_m + k) \\ 0 & \text{otherwise;} \end{cases}$$

*if  $k = 0$  and  $d > 1$ ,*

$$CF_i(B, m) = \begin{cases} \mathbb{Z}_2^2 & i \in (d - 1)\mathbb{N}_m \\ 0 & \text{otherwise;} \end{cases}$$

*if  $k = 0$  and  $d = 1$ ,*

$$CF_i(B, m) = \begin{cases} \mathbb{Z}_2^{2m} & i = 0 \\ 0 & \text{otherwise.} \end{cases}$$

**Theorem 2.13.** *Assume that  $(B, g)$  is a  $d$ -dimensional  $SC_k$ -manifold. If  $d = 2$  or  $k = 1$ , assume that  $(B, g) = (\mathbb{C}P^n, g_{\text{can}})$ . Then the Floer boundary operator  $\partial_* : CF_*(B, m) \rightarrow CF_{*-1}(B, m)$  vanishes identically, and so  $HF_*(B, m) = CF_*(B, m)$ . In particular,  $\text{rank } HF(B, m) = 2m$ .*

*Proof.* We first assume that  $d \neq 2$  and  $k \neq 1$ . Corollary 2.12 then shows that for any  $*$   $\in \mathbb{Z}$ , at least one of the chain groups  $CF_*(B, m)$  and  $CF_{*-1}(B, m)$  is trivial, and so  $\partial_* = 0$ . It remains to prove the vanishing of  $\partial_*$  for  $(\mathbb{C}P^n, g_{\text{can}})$ ,  $n \geq 1$ . We shall do this by using a symmetry argument.

**The case  $(\mathbb{C}P^n, g_{\text{can}})$ .** Note that every diffeomorphism  $\varphi$  of  $\mathbb{C}P^n$  lifts to a symplectomorphism  $(\varphi^{-1})^*$  of  $T^*\mathbb{C}P^n$ , and that if  $\varphi$  is an isometry, then  $(\varphi^{-1})^*$  is a symplectomorphism of  $T_1^*\mathbb{C}P^n$ . Let  $\mathbb{R}P^n$  be the real locus of  $\mathbb{C}P^n$ .

LEMMA 2.14. *We can assume without loss of generality that  $x, y \in \mathbb{R}P^n$ .*

*Proof.* Choose a unitary matrix  $U \in \mathbf{U}(n + 1)$  such that  $x' = U(x) = [1 : 0 : \dots : 0] \in \mathbb{R}P^n$  and  $y' = U(y) \in \mathbb{R}P^n$ . We again identify  $T_1^*\mathbb{C}P^n$  with  $T_1\mathbb{C}P^n$  via the Riemannian metric  $g_{\text{can}}$ . Since  $U$  is an isometry of  $(\mathbb{C}P^n, g_{\text{can}})$ , its lift  $U_*$  to  $T_1\mathbb{C}P^n$  commutes with the geodesic flow on  $T_1\mathbb{C}P^n$ , and hence  $(U^{-1})^*$  commutes with  $\vartheta^m$ . Therefore,

$$(U^{-1})^*L_0 = (U^{-1})^*\vartheta^m(D_x) = \vartheta^m(U^{-1})^*(D_x) = \vartheta^m(D_{x'})$$

and  $(U^{-1})^*L_1 = (U^{-1})^*D_y = D_{y'}$ . By the natural invariance of Lagrangian Floer homology we thus obtain

$$\begin{aligned} HF_*(T_1\mathbb{C}P^n, L_0, L_1) &= HF_*(T_1\mathbb{C}P^n, (U^{-1})^*L_0, (U^{-1})^*L_1) \\ &= HF_*(T_1\mathbb{C}P^n, \vartheta^m(D_{x'}), D_{y'}), \end{aligned}$$

as desired. □

Consider the involution

$$[z_0 : z_1 : \dots : z_n] \mapsto [\bar{z}_0 : \bar{z}_1 : \dots : \bar{z}_n] \tag{11}$$

of  $\mathbb{C}P^n$ . Its fixed point set is  $\mathbb{R}P^n$ . Since complex conjugation (11) is an isometry of  $(\mathbb{C}P^n, g_{\text{can}})$ , it lifts to a symplectic involution  $\sigma$  of  $T_1^*\mathbb{C}P^n$ . Since  $x, y \in \mathbb{R}P^n$  and since complex conjugation is an isometry, we see as in the proof of Lemma 2.14 that  $\sigma(L_j) = L_j$ ,  $j = 0, 1$ . Moreover,  $\sigma$  acts trivially on  $L_0 \cap L_1$ . Indeed, two different geodesics through  $x$  either meet in  $x$  only or in  $x$  and in one point of the cut locus  $C(x)$  diffeomorphic to  $\mathbb{C}P^{n-1}$ , see [B, 3.33]. Since by assumption  $y \in W = \mathbb{C}P^n \setminus (\{x\} \cup C(x))$ , there is only one geodesic circle containing  $x$  and  $y$ . It lies in  $\mathbb{R}P^n$  because  $\mathbb{R}P^n$  is a totally geodesic submanifold of  $(\mathbb{C}P^n, g_{\text{can}})$ . It follows that  $\sigma$  fixes  $L_0 \cap L_1$ .

Assume that  $\mathbf{J} \in \mathcal{J}(T_1^*\mathbb{C}P^n)$  is invariant under  $\sigma$ , i.e.  $\sigma^*J_t = \sigma_*J_t\sigma_* = J_t$  for every  $t \in [0, 1]$ . Then  $\sigma$  induces an involution on the solutions of (9) by

$$u \mapsto \sigma \circ u.$$

If  $u$  is invariant under  $\sigma$ , i.e.  $u = \sigma \circ u$ , then  $u$  is a solution of (9) with  $M$  replaced by the fixed point set  $M^\sigma = T_1^*\mathbb{R}P^n$  of  $\sigma$  and  $L_j$  replaced by  $L_j^\sigma = L_j \cap M^\sigma$  for  $j = 0, 1$ . According to Proposition 2.1,  $\mathbb{C}P^n$  is an  $SC_1$ -manifold and  $\mathbb{R}P^n$  is an  $SC_0$ -manifold, and so we read off from Corollary 2.12 that

if  $\text{ind}_M(c_-) - \text{ind}_M(c_+) = 1$ , then  $\text{ind}_{M^\sigma}(c_-) - \text{ind}_{M^\sigma}(c_+) = 0$ . One thus expects that for generic  $\sigma$ -invariant  $\mathbf{J} \in \mathcal{J}$  there are no solutions of (9) which are invariant under  $\sigma$ . In particular, solutions of (9) appear in pairs, and so  $\partial_* = 0$ . To make this argument precise, we need to show that there exist  $\sigma$ -invariant  $\mathbf{J} \in \mathcal{J}$  which are “regular” for every non-invariant solution of (9) and whose restriction to  $M^\sigma$  is also “regular”. This will be done in the next paragraph.

**2.5.1 A transversality theorem.** We consider, more generally, an exact compact symplectic manifold  $(M, \omega)$  with boundary  $\partial M$  containing two compact Lagrangian submanifolds  $L_0$  and  $L_1$  as in 2.4.1: (H1), (H2), (H3) hold and there is a Liouville vector field  $X$  on a neighbourhood  $U$  of  $\partial M$  such that (H4) holds. We in addition assume that  $\sigma$  is a symplectic involution of  $(M, \omega)$  such that

$$\sigma(L_j) = L_j \text{ for } j = 0, 1, \quad \sigma|_{L_0 \cap L_1} = \text{id}, \quad \sigma_*X = X. \quad (12)$$

We have already verified the first two properties for  $M = T_1^* \mathbb{C}P^n$  and the lift  $\sigma$  of (11), and we notice that  $\sigma_*X = X$  for the Liouville vector field (10). The fixed point set  $M^\sigma = \text{Fix}(\sigma)$  is a symplectic submanifold of  $(M, \omega)$ . Set  $\omega^\sigma = \omega|_{M^\sigma}$ . Since  $\sigma_*X = X$  the vector field  $X^\sigma = X|_{U \cap M^\sigma}$  is a Liouville vector field near  $\partial M^\sigma$ . As in 2.4.1 we denote by  $\mathcal{J} = \mathcal{J}(M)$  the space of smooth families  $\mathbf{J} = \{J_t\}$ ,  $t \in [0, 1]$ , of smooth  $\omega$ -compatible almost complex structures on  $M$  which on  $V$  do not depend on  $t$  and meet (J1), (J2), (J3). The space  $\mathcal{J}(M^\sigma)$  is defined analogously by imposing (J1), (J2), (J3) for  $X^\sigma$  on  $M^\sigma \cap V$ . The subspace of those  $\mathbf{J}$  in  $\mathcal{J}(M)$  which are  $\sigma$ -invariant is denoted  $\mathcal{J}^\sigma(M)$ . There is a natural restriction map

$$\rho : \mathcal{J}^\sigma(M) \rightarrow \mathcal{J}(M^\sigma), \quad \mathbf{J} \mapsto \mathbf{J}|_{TM^\sigma}.$$

LEMMA 2.15. *The restriction map  $\rho$  is open.*

*Proof.* Recall that  $\varphi_r$ ,  $r \leq 0$ , denotes the semiflow of  $X$ , and that  $\xi$  and  $R$  are the contact structure and the Reeb vector field on  $\partial M$  defined by (7) and (8). Since  $\sigma$  is symplectic,  $\sigma_*X = X$  and  $\sigma(\partial M) = \partial M$  we have

$$\sigma_*\xi = \xi \quad \text{and} \quad \sigma_*R = R.$$

The contact structure  $\xi^\sigma$  on  $\partial M^\sigma$  associated with  $X^\sigma$  is  $\xi \cap T\partial M^\sigma$ , and the Reeb vector field  $R^\sigma$  is  $R|_{\partial M^\sigma}$ . We shall prove Lemma 2.15 by first showing that  $\rho$  is onto. From the proof it will then easily follow that  $\rho$  is open.

**Step 1.  $\rho$  is onto:** Fix  $\mathbf{J}^\sigma \in \mathcal{J}(M^\sigma)$ . We set  $g_t^\sigma = \omega \circ (\text{id} \times J_t^\sigma)$ . Choose a smooth family  $\mathbf{g} = \{g_t\}$ ,  $t \in [0, 1]$ , of Riemannian metrics on  $TM$  which on  $V$  does not depend on  $t$  and satisfies

- (g1)  $g(X(x), v) = 0, x \in \partial M, v \in T_x \partial M,$
- (g2)  $g(X(x), X(x)) = 1, x \in \partial M,$
- (g3)  $\varphi_r^* g(x) = e^r g(x), x \in \partial M, r \in [-\epsilon', 0],$
- (g4)  $g(R(x), R(x)) = 1, x \in \partial M,$
- (g5)  $g(R(x), v) = 0, x \in \partial M, v \in \xi,$

and in addition satisfies for each  $t$

- (g6) if  $x \in M^\sigma$ , then  $g_t(x)|_{T_x M^\sigma} = g_t^\sigma(x),$
- (g7) if  $x \in M^\sigma$ , then the Riemannian and the symplectic orthogonal complement of  $T_x M^\sigma$  in  $T_x M$  coincide, i.e. if for  $\eta \in T_x M$  it holds that  $\omega(\eta, \zeta) = 0$  for every  $\zeta \in T_x M^\sigma$ , then also  $g(\eta, \zeta) = 0$  for every  $\zeta \in T_x M^\sigma$ ,
- (g8)  $\sigma^* g_t = g_t.$

In order to see that such a family  $\mathbf{g}$  exists, first notice that in view of (J1), (J2), (J3), Lemma 2.5 and (8), the metric  $g^\sigma$  satisfies (g1)–(g5) for  $X^\sigma, R^\sigma, x \in \partial M^\sigma$  and  $v \in T_x \partial M^\sigma$  or  $v \in \xi^\sigma$ . We thus find a family  $\mathbf{g}_0$  satisfying (g1)–(g7). Then  $\sigma^* \mathbf{g}_0$  also satisfies (g1)–(g7) as one readily verifies; we only mention that (g3) follows from  $\sigma^* \circ \varphi_r = \varphi_r \circ \sigma$  which is a consequence of  $\sigma_* X = X$ . Now set

$$\mathbf{g} = \frac{1}{2}(\mathbf{g}_0 + \sigma^* \mathbf{g}_0).$$

Let  $\mathfrak{Met}$  be the space of smooth Riemannian metrics on  $M$  and let  $\mathcal{J}(\omega)$  be the space of smooth  $\omega$ -compatible almost complex structures on  $M$ . For  $J \in \mathcal{J}(\omega)$  we write  $g_J = \omega \circ (\text{id} \times J) \in \mathfrak{Met}$ . It is shown in [MS1, Proposition 2.50 (ii)] that there exists a smooth map

$$r : \mathfrak{Met} \rightarrow \mathcal{J}(\omega), \quad g \mapsto r(g) =: J_g,$$

such that

$$r(g_J) = J \quad \text{and} \quad r(\varphi^* g) = \varphi^* r(g) \tag{13}$$

for every symplectomorphism  $\varphi$  of  $M$ . We define  $\mathbf{J} = \{J_t\}$  by

$$J_t = r(g_t).$$

The second property in (13) and (g8) show that  $\mathbf{J}$  is  $\sigma$ -invariant. In order to prove that  $\mathbf{J} \in \mathcal{J}^\sigma(M)$  we also need to show that each  $J_t$  meets (J1), (J2), (J3) and  $J_t|_{M^\sigma} = J_t^\sigma$ . To this end we must recall the construction of  $r$  from [MS1]. Fix  $g \in \mathfrak{Met}$  and  $x \in M$ . The automorphism  $A$  of  $T_x M$  defined by  $\omega_x(v, w) = g_x(Av, w)$  is  $g$ -skew-adjoint. Denoting by  $A^*$  its  $g$ -adjoint, we find that  $P = A^* A = -A^2$  is  $g$ -positive definite. Let  $Q$  be the automorphism of  $T_x M$  which is  $g$ -self-adjoint,  $g$ -positive definite, and satisfies  $Q^2 = P$ , and then set

$$J_x(\omega, g) = Q^{-1} A.$$

It is clear that  $J_x(\omega, g)$  depends smoothly on  $x$ . The map  $r$  is defined by  $r(g)(x) = J_x(\omega, g)$ . One readily verifies that  $r(g)$  is  $\omega$ -compatible, see [HZ, p. 14], and meets (13). From the construction we moreover read off that

- (r1)  $J_x(c_1\omega, c_2g) = J_x(\omega, g)$  for all  $c_1, c_2 > 0$ ,
- (r2) if  $T_xM = V \oplus W$  in such a way that  $W$  is both  $\omega$ -orthogonal and  $g$ -orthogonal to  $V$ , i.e.  $W = V^\omega = V^\perp$ , then  $A, P$  and  $Q$  leave both  $V$  and  $W$  invariant, so that  $J_x(\omega, g)$  leaves  $V$  invariant and

$$J_x(\omega, g)|_V = J_x(\omega|_V, g|_V).$$

We are now in position to verify (J1), (J2), (J3) for  $J_t = r(g_t) = J_{g_t}$ . In view of (7) and (8) and (g1) and (g5) the plane field  $\langle X, R \rangle$  on  $\partial M$  generated by  $X$  and  $R$  is both  $\omega$ -orthogonal and  $g$ -orthogonal to  $\xi$ ,

$$\langle X, R \rangle = \xi^\omega = \xi^\perp,$$

and so (r2) implies

$$J_g|\langle X, R \rangle = J_{g|\langle X, R \rangle}. \tag{14}$$

Define the complex structure  $J_0$  on  $\langle X, R \rangle$  by  $J_0X = R$ . Using (g1), (g2), (g4) and (8) we find  $g|\langle X, R \rangle = g_{J_0}$ , and so the first property in (13) implies  $J_{g|\langle X, R \rangle} = J_0$ . Together with (14) we find

$$J_g|\langle X, R \rangle = J_0. \tag{15}$$

The  $J_g$ -invariance of  $\omega$ , (15) and (8) yield (J1) and (J2). The identity (J3) follows from  $\varphi_r^*\omega = e^r\omega$ , (g3) and (r1). Finally,  $J_t|_{M^\sigma} = J_t^\sigma$  follows from (g6), (g7), (r2) and the first property in (13).

**Step 2.  $\rho$  is open:** Let  $U$  be an open subset of  $\mathcal{J}^\sigma(M)$ . We must show that given  $\mathbf{J}^\sigma \in \rho(U)$ , every  $(C^\infty)$ -close enough  $\tilde{\mathbf{J}}^\sigma \in \mathcal{J}(M^\sigma)$  belongs to  $\rho(U)$ . Fix  $\mathbf{J} \in U$  with  $\rho(\mathbf{J}) = \mathbf{J}^\sigma$ , and set  $\mathbf{g} = g_{\mathbf{J}}$ . Since  $\mathbf{J} \in \mathcal{J}^\sigma(M)$ , the family  $\mathbf{g}$  satisfies (g1)–(g8). If  $\tilde{\mathbf{J}}^\sigma \in \mathcal{J}(M^\sigma)$  is close to  $\mathbf{J}^\sigma$ , then  $\tilde{\mathbf{g}}^\sigma = g_{\tilde{\mathbf{J}}^\sigma}$  is close to  $g_{\mathbf{J}^\sigma}$ , and so we can choose a smooth family  $\tilde{\mathbf{g}}_0$  close to  $\mathbf{g}$  which satisfies (g1)–(g7). Then

$$\tilde{\mathbf{g}} = \frac{1}{2}(\tilde{\mathbf{g}}_0 + \sigma^*\tilde{\mathbf{g}}_0)$$

satisfies (g1)–(g8), and since  $\tilde{\mathbf{g}}_0$  was close to  $\mathbf{g}$  and since  $\sigma^*\mathbf{g} = \mathbf{g}$ , the family  $\tilde{\mathbf{g}}$  is also close to  $\mathbf{g}$ . Set  $\tilde{\mathbf{J}} = r(\tilde{\mathbf{g}})$ . Then  $\rho(\tilde{\mathbf{J}}) = \tilde{\mathbf{J}}^\sigma$ , and since  $r : \mathfrak{Met} \rightarrow \mathcal{J}(\omega)$  is smooth and  $\tilde{\mathbf{g}}$  is close to  $\mathbf{g}$ , we see that  $\tilde{\mathbf{J}} = r(\tilde{\mathbf{g}})$  is close to  $r(\mathbf{g}) = r(g_{\mathbf{J}}) = \mathbf{J}$ . In particular, if  $\tilde{\mathbf{J}}^\sigma$  was close enough to  $\mathbf{J}^\sigma$ , then  $\tilde{\mathbf{J}} \in U$ . The proof of Lemma 2.15 is complete.  $\square$

For the remainder of the proof of Theorem 2.13 for  $(\mathbb{C}P^n, g_{\text{can}})$  we assume that the reader is familiar with the standard transversality arguments

in Floer theory as presented in Section 5 of [FHS] or Sections 3.1 and 3.2 of [MS2], and we shall focus on those aspects of the argument particular to our situation. Fix  $c_-, c_+ \in L_0 \cap L_1$ . We interpret solutions of (9) with  $\lim_{s \rightarrow \pm\infty} u(s, t) = c_\pm$  as the zero set of a smooth section from a Banach manifold  $\mathcal{B}$  to a Banach bundle  $\mathcal{E}$  over  $\mathcal{B}$ . We fix  $p > 2$ . According to Lemma D.1 in [RS] there exists a smooth family of Riemannian metrics  $\{g_t\}$ ,  $t \in [0, 1]$ , on  $M$  such that  $L_j$  is totally geodesic with respect to  $g_j$ ,  $j = 0, 1$ . Let  $\mathcal{B} = \mathcal{B}^{1,p}(c_-, c_+)$  be the space of continuous maps  $u$  from the strip  $S = \mathbb{R} \times [0, 1]$  to the interior of  $M$  which satisfy  $\lim_{s \rightarrow \pm\infty} u(s, t) = c_\pm$  uniformly in  $t$ , are locally of class  $W^{1,p}$ , and satisfy the conditions

- (B1)  $u(s, j) \in L_j$  for  $j = 0, 1$ ,
- (B2) there exists  $T > 0$ ,  $\xi_- \in W^{1,p}((-\infty, -T] \times [0, 1], T_{c_-} M)$ , and  $\xi_+ \in W^{1,p}([T, \infty) \times [0, 1], T_{c_+} M)$  with  $\xi_\pm(s, j) \in T_{c_\pm} L_j$  such that

$$u(s, t) = \begin{cases} \exp_{c_-}(\xi_-(s, t)), & s \leq -T, \\ \exp_{c_+}(\xi_+(s, t)), & s \geq T. \end{cases}$$

Here,  $\exp_{c_\pm}(\xi_\pm(s, t))$  denotes the image of  $\xi_\pm(s, t)$  under the exponential map with respect to  $g_t$  at  $c_\pm$ . The space  $\mathcal{B}$  is an infinite dimensional Banach manifold whose tangent space at  $u$  is

$$T_u \mathcal{B} = \{ \xi \in W^{1,p}(S, u^* TM) \mid \xi(s, j) \in T_{u(s, j)} L_j, j = 0, 1 \}.$$

Let  $\mathcal{E}$  be the Banach bundle over  $\mathcal{B}$  whose fibre over  $u \in \mathcal{B}$  is

$$\mathcal{E}_u = L^p(S, u^* TM).$$

For  $\mathbf{J} \in \mathcal{J}(M)$  define the section  $\mathcal{F}_\mathbf{J} : \mathcal{B} \rightarrow \mathcal{E}$  by

$$\mathcal{F}_\mathbf{J}(u) = \partial_s u + J_t(u) \partial_t(u)$$

and set  $\mathcal{M}_\mathbf{J} = \mathcal{F}_\mathbf{J}^{-1}(0)$ . The set  $\mathcal{M}_\mathbf{J}$  agrees with the set of those  $u \in \mathcal{M}(\mathbf{J})$  with  $\lim_{s \rightarrow \pm\infty} u(s, t) = c_\pm$ . Indeed, Lemma 2.6 and Proposition 1.21 in [FHS] show that the latter set belongs to  $\mathcal{M}_\mathbf{J}$ . Conversely, in view of  $p > 2$ , elliptic regularity and (B2) imply that  $u \in \mathcal{M}_\mathbf{J}$  is smooth and satisfies  $\lim_{s \rightarrow \pm\infty} \partial_s u(s, t) = 0$  uniformly in  $t$ , so that  $E(u) < \infty$  by Proposition 1.21 in [FHS]. If  $u \in \mathcal{M}_\mathbf{J}$ , then the vertical differential of  $\mathcal{F}_\mathbf{J}$ ,

$$D_{u, \mathbf{J}} \equiv D\mathcal{F}_\mathbf{J}(u) : T_u \mathcal{B} \rightarrow \mathcal{E}_u, \quad \xi \mapsto \nabla_s \xi + J_t(u) \nabla_t \xi + \nabla_\xi J_t(u) \partial_t u,$$

is a Fredholm operator, cf. [S, Theorem 2.2]. Here,  $\nabla$  denotes the Levi-Civita connection with respect to the  $t$ -dependent metric  $g_{J_t}$ . We further consider the Banach submanifold

$$\mathcal{B}^\sigma = \{ u \in \mathcal{B} \mid u = \sigma \circ u \},$$

of those  $u$  in  $\mathcal{B}$  whose image lies in  $M^\sigma$ . We denote by  $\mathcal{E}^\sigma$  the Banach bundle over  $\mathcal{B}^\sigma$  whose fibre over  $u \in \mathcal{B}^\sigma$  is

$$\mathcal{E}_u^\sigma = L^p(S, u^*TM^\sigma).$$

Note that  $\mathcal{E}^\sigma$  is a subbundle of the restriction of  $\mathcal{E}$  to  $\mathcal{B}^\sigma$ . For  $\mathbf{J} \in \mathcal{J}^\sigma(M)$  we abbreviate

$$\mathcal{M}_\mathbf{J}^\sigma \equiv \mathcal{F}_\mathbf{J}^{-1}(0) \cap \mathcal{B}^\sigma = \mathcal{M}_\mathbf{J} \cap \mathcal{B}^\sigma$$

and for  $u \in \mathcal{M}_\mathbf{J}^\sigma$  we set

$$D_{u,\mathbf{J}}^\sigma \equiv D_{u,\mathbf{J}}|_{T_u\mathcal{B}^\sigma} : T_u\mathcal{B}^\sigma \rightarrow \mathcal{E}_u^\sigma.$$

DEFINITION 2.16. We say that  $\mathbf{J} \in \mathcal{J}^\sigma(M)$  is *regular* if for every  $u \in \mathcal{M}_\mathbf{J} \setminus \mathcal{M}_\mathbf{J}^\sigma$  the operator  $D_{u,\mathbf{J}}$  is onto and if for every  $u \in \mathcal{M}_\mathbf{J}^\sigma$  the operator  $D_{u,\mathbf{J}}^\sigma$  is onto.

PROPOSITION 2.17. *The set  $(\mathcal{J}^\sigma(M))_{\text{reg}}$  of regular almost complex structures is generic in  $\mathcal{J}^\sigma(M)$ .*

*Proof.* It is proved in [KhS, Proposition 5.13] that the subset  $\mathcal{R}_1$  of those  $\mathbf{J} \in \mathcal{J}^\sigma(M)$  for which  $D_{u,\mathbf{J}}$  is onto for every  $u \in \mathcal{M}_\mathbf{J} \setminus \mathcal{M}_\mathbf{J}^\sigma$  is generic in  $\mathcal{J}^\sigma(M)$ . Moreover, it is proved in [FHS, Section 5] that the subset  $\mathcal{R}_2^\sigma$  of those  $\mathbf{J} \in \mathcal{J}(M^\sigma)$  for which  $D_{u,\mathbf{J}^\sigma}$  is onto for every  $u \in \mathcal{M}_\mathbf{J}^\sigma$  is generic in  $\mathcal{J}(M^\sigma)$ . Notice that for  $\mathbf{J} \in \mathcal{J}^\sigma(M)$  we have  $\mathcal{M}_\mathbf{J}^\sigma = \mathcal{M}_{\rho(\mathbf{J})}$  and  $D_{u,\mathbf{J}}^\sigma = D_{u,\rho(\mathbf{J})}$  for  $u \in \mathcal{M}_\mathbf{J}^\sigma = \mathcal{M}_{\rho(\mathbf{J})}$ . It follows that for  $\mathbf{J} \in \mathcal{R}_2 \equiv \rho^{-1}(\mathcal{R}_2^\sigma)$  the operator  $D_{u,\mathbf{J}}^\sigma$  is onto for every  $u \in \mathcal{M}_\mathbf{J}^\sigma$ . Since the preimage of a generic set under a continuous open map is generic,  $\mathcal{R}_2$  is generic in  $\mathcal{J}^\sigma(M)$ . Therefore, the set of regular  $\mathbf{J} \in \mathcal{J}^\sigma(M)$  contains the generic set  $\mathcal{R}_1 \cap \mathcal{R}_2$ , and the proof of Proposition 2.17 is complete.  $\square$

In order to complete the proof of Theorem 2.13 for  $(\mathbb{C}P^n, g_{\text{can}})$ , set again  $M = T_1^* \mathbb{C}P^n$ . In view of Proposition 2.17 we find a  $\mathbf{J} \in \mathcal{J}^\sigma(M)$  which is regular for all  $c_-, c_+ \in L_0 \cap L_1$ . Fix  $c_-, c_+$  with  $\text{ind}_M(c_-) - \text{ind}_M(c_+) = 1$ . Since  $\text{ind}_{M^\sigma}(c_-) - \text{ind}_{M^\sigma}(c_+) = 0$ , the Fredholm index of  $D_{u,\mathbf{J}}^\sigma$  for  $u \in \mathcal{M}_\mathbf{J}^\sigma$  vanishes, so that the manifold of solutions of (9) contained in  $M^\sigma$  is 0-dimensional and hence empty. Moreover,  $D_{u,\mathbf{J}}$  is onto for every  $u \in \mathcal{M}_\mathbf{J} \setminus \mathcal{M}_\mathbf{J}^\sigma$ , and so  $D_{u,\mathbf{J}}$  is onto for every  $u \in \mathcal{M}_\mathbf{J}$ . We can thus compute the Floer homology  $HF_*(M, L_0, L_1)$  by using  $\mathbf{J}$ . Since  $\mathcal{M}_\mathbf{J}^\sigma$  is empty,  $\partial_* = 0$ , and the proof of Theorem 2.13 for  $(\mathbb{C}P^n, g_{\text{can}})$  is complete.  $\square$

**2.6 End of the proof of Theorem 1.** We recall that Theorem 1 is a special case of Theorem 2.3. For  $(B, g) = S^1$ , Theorem 2.3 follows from the topological argument given in section 2.1, see also Corollary 2.21 below. For the remainder of this section we therefore assume that  $(B, g)$  is a  $P$ -manifold of dimension  $d \geq 2$ . We abbreviate  $M = T^*B$  and  $M_r = T_r^*B$ .

The group  $\text{Ham}^c(M)$  is the union of the groups  $\text{Ham}^c(M_r)$ ,  $r > 0$ , defined before Proposition 2.9.

LEMMA 2.18.  $\text{Ham}^c(M) = \text{Symp}_0^c(M)$ .

*Proof.* Since  $M$  is orientable, Poincaré duality yields

$$H_c^1(M; \mathbb{R}) \cong H_{2d-1}(M; \mathbb{R}) \cong H_{2d-1}(B; \mathbb{R}) = 0.$$

The lemma now follows in view of the exact sequence

$$0 \rightarrow \text{Ham}^c(M) \rightarrow \text{Symp}_0^c(M) \rightarrow H_c^1(M; \mathbb{R}) \rightarrow 0$$

where the first map is inclusion and the second map is the flux homomorphism  $\varphi \mapsto [\varphi^*\lambda - \lambda]$ , see [MS1, Chapter 10]. □

**Case 1. SC-manifolds as in Theorem 2.13.** Let now  $(B, g)$  be an SC-manifold as in Theorem 2.13. Let  $\vartheta = \vartheta_f$  be the twist considered in section 2.5, and let  $\varphi \in \text{Symp}^c(M)$  be such that  $[\varphi] = [\vartheta^m] \in \pi_0(\text{Symp}^c(M))$  for some  $m \in \mathbb{Z} \setminus \{0\}$ . We assume without loss of generality that  $m \geq 1$ . By Lemma 2.18 we find  $r > 0$  such that  $\vartheta^m \varphi^{-1} \in \text{Ham}^c(M_r)$ . Then  $\vartheta^{mn} \varphi^{-n} \in \text{Ham}^c(M_r)$  for all  $n \geq 1$ . We assume without loss of generality that  $r = 1$ . Let  $W$  be the non-empty open subset of  $B$  defined in 2.5, and fix  $y \in W$ . We first assume that  $\varphi^n(D_x)$  intersects  $D_y$  transversally. Then  $HF(M_1, \varphi^n(D_x), D_y)$  is defined, and in view of Proposition 2.9 and Theorem 2.13 we find that

$$\begin{aligned} \text{rank } CF(M_1, \varphi^n(D_x), D_y) &\geq \text{rank } HF(M_1, \varphi^n(D_x), D_y) \\ &= \text{rank } HF(M_1, \vartheta^{mn}(D_x), D_y) \\ &= 2mn. \end{aligned}$$

It follows that the  $d$ -dimensional submanifold  $\varphi^n(D_x)$  of  $M_1$  intersects  $D_y$  at least  $2mn$  times. Since this holds true for every  $y \in W$  and since  $\pi : (M_1, g^*) \rightarrow (B, g)$  is a Riemannian submersion, we conclude that

$$\mu_{g^*}(\varphi^n(D_x)) \geq 2mn\mu_g(W).$$

If  $\varphi^n(D_x)$  and  $D_y$  are not transverse, we choose a sequence  $\varphi_i \in \text{Symp}^c(M_1)$  such that  $\varphi_i^n(D_x)$  and  $D_y$  are transverse for all  $i$ , and  $\varphi_i \rightarrow \varphi$  in the  $C^\infty$ -topology. For  $i$  large enough,  $[\varphi_i] = [\varphi] \in \pi_0(\text{Symp}^c(M_1))$ , and

$$\mu_{g^*}(\varphi^n(D_x)) = \lim_{i \rightarrow \infty} \mu_{g^*}(\varphi_i^n(D_x)) \geq 2mn\mu_g(W). \tag{16}$$

Choose a smooth embedding  $\sigma : Q^d \rightarrow T_x^*B$  such that  $D_x \subset \sigma(Q^d)$ . Then  $\mu_{g^*}(\varphi^n(\sigma)) \geq (2m\mu_g(W))n$ , and so  $s_d(\varphi) \geq l(\varphi) \geq 1$ , as claimed.

**Case 2. Riemannian quotients.** Assume next that  $(B, g)$  is a Riemannian quotient of an  $SC$ -manifold  $(\tilde{B}, \tilde{g})$  as in Case 1, and that  $[\varphi] = [\vartheta^m] \in \pi_0(\text{Symp}^c(M))$ . For this proof we assume that  $g$  and  $\tilde{g}$  are locally isometric. Suppose that  $B = \tilde{B}/G$  and that  $q$  is the smallest number such that  $h^q = 1$  for all  $h \in G$ . Then the twist  $\tilde{\vartheta}$  on  $\tilde{M} = T^*\tilde{B}$  is a lift of  $\vartheta^q$ , and so  $\tilde{\vartheta}^m$  is a lift of  $\vartheta^{mq}$ . Lifting a symplectic isotopy between  $\vartheta^{mq}$  and  $\varphi^q$  to  $\tilde{M}$ , we obtain a symplectic isotopy between  $\tilde{\vartheta}^m$  and a lift  $\tilde{\varphi}$  of  $\varphi^q$ . Since the projection  $\tilde{M} \rightarrow M$  is a local isometry, we thus obtain from (16) that

$$\mu_{g^*}(\varphi^{nq}(D_x)) = \mu_{\tilde{g}^*}(\tilde{\varphi}^n(D_{\tilde{x}})) \geq 2mn\mu_{\tilde{g}}(W) =: cn \tag{17}$$

for any  $x \in B$  and a lift  $\tilde{x} \in \tilde{B}$ . We denote by  $\|D_z\varphi\|$  the operator norm of the differential of  $\varphi$  at a point  $z \in M$  with respect to  $g^*$ , and we abbreviate  $\|D\varphi\| = \max_{z \in M} \|D_z\varphi\|$ . Using the estimate (17) we find for every  $n \in \mathbb{N}$  and  $p \in \{0, 1, \dots, q-1\}$  that

$$\begin{aligned} \mu_{g^*}(\varphi^{nq-p}(D_x)) &\geq \|D\varphi\|^{-pd} \mu_{g^*}(\varphi^{nq}(D_x)) \\ &\geq \|D\varphi\|^{-pd} cn \\ &\geq (\|D\varphi\|^{-pd} cq^{-1})(nq - p). \end{aligned}$$

This proves  $s_d(\varphi) \geq l(\varphi) \geq 1$ .

**Case 3. Surfaces different from  $(S^2, g_{\text{can}})$ .** Assume finally that  $(B, g)$  is a  $P$ -manifold modelled on a surface. Since  $\pi_1(B)$  is finite,  $B = S^2$  or  $B = \mathbb{R}P^2$ . By the argument in Case 2, the latter case is reduced to the former one. So assume that  $(B, g)$  is a  $P$ -manifold modelled on  $S^2$ , and let  $\vartheta$  be a twist defined by  $g$ . According to [S1],  $\pi_0(\text{Symp}^c(T^*S^2))$  is generated by the class  $[\tau]$  of a generalized Dehn twist  $\tau$  defined with respect to  $g_{\text{can}}$ , and so  $[\vartheta] = [\tau^k]$  for some  $k \in \mathbb{Z}$ . Clearly,  $\vartheta \neq \text{id}$ . If  $k = 0$ , the estimate  $s_1(\vartheta) = l(\vartheta) \geq 1$  therefore follows from Remark 1, and if  $k \neq 0$  from Corollary 1. The proof of Theorem 2.3 is complete.  $\square$

**2.7 Proof of Corollary 1.** Let  $\varphi \in \text{Symp}^c(T^*S^d)$  be such that  $[\varphi] = [\tau^m] \in \pi_0(\text{Symp}^c(T^*S^d))$  for some  $m \in \mathbb{Z} \setminus \{0\}$ . Since  $[\tau^2] = [\vartheta]$ , we then have  $[\varphi^2] = [\vartheta^m]$ . Proceeding as in Case 1 above and assuming again  $r = 1$  we find  $c > 0$  such that

$$\mu_{g^*}(\varphi^{2n}(D_x)) \geq cn \tag{18}$$

for all  $n \geq 1$ . We denote by  $\|D_z\varphi\|$  the operator norm of the differential of  $\varphi$  at a point  $z \in T^*S^d$  with respect to  $g^*$ , and we abbreviate  $\|D\varphi\| = \max_{z \in T^*S^d} \|D_z\varphi\|$ . Using the estimate (18) we find

$$\mu_{g^*}(\varphi^{2n+1}(D_x)) \geq \|D\varphi\|^{-d} \mu_{g^*}(\varphi^{2n+2}(D_x)) \geq \|D\varphi\|^{-d} c(n+1). \tag{19}$$

The estimates (18) and (19) now show that  $l(\varphi) \geq 1$ , as claimed.  $\square$

**2.8 A remark on smoothness.** Given a  $P$ -manifold  $B$ , let  $\text{Symp}^{c,1}(T^*B)$  be the group of compactly supported  $C^1$ -smooth symplectomorphisms of  $(T^*B, d\lambda)$  endowed with the  $C^1$ -topology. According to a result of Zehnder, [Z],  $\text{Symp}^c(T^*B)$  is dense in  $\text{Symp}^{c,1}(T^*B)$ , and by a result of Weinstein, [MS1, Theorem 10.1], both groups are locally path connected. It follows that the inclusion  $\text{Symp}^c(T^*B) \rightarrow \text{Symp}^{c,1}(T^*B)$  induces an isomorphism of mapping class groups,  $\pi_0(\text{Symp}^c(T^*B)) = \pi_0(\text{Symp}^{c,1}(T^*B))$ .

**PROPOSITION 2.19.** *Theorem 2.3 and Corollary 1 hold true for  $C^1$ -smooth symplectomorphisms.*

*Proof.* Let  $(B, g)$  be as in Theorem 2.3, and let  $\varphi \in \text{Symp}^{c,1}(T^*B)$  be such that  $[\varphi] = [\vartheta^m] \in \pi_0(\text{Symp}^c(T^*B))$  for some  $m \in \mathbb{Z} \setminus \{0\}$ . We can assume that  $\varphi$  is supported in  $T_1^*B$ . Choose a sequence  $\varphi_i \in \text{Symp}^c(T_1^*B)$  such that  $\varphi_i \rightarrow \varphi$  in the  $C^1$ -topology. For  $i$  large enough,  $[\varphi_i] = [\varphi] \in \pi_0(\text{Symp}^c(T^*B))$ . Using the estimate (16) we thus conclude

$$\mu_{g^*}(\varphi^n(D_x)) = \lim_{i \rightarrow \infty} \mu_{g^*}(\varphi_i^n(D_x)) \geq 2mn\mu_g(U)$$

for all  $n \geq 1$ . Therefore,  $s_d(\varphi) \geq l(\varphi) \geq 1$ . Corollary 1 now follows also for  $C^1$ -smooth symplectomorphisms.  $\square$

**2.9 Differential topology of twists.** In this section we collect results concerning the differential topology of twists. We shall in particular see that for odd spheres and their quotients, Theorem 1 already holds for topological reasons, while for even spheres and  $\mathbb{C}P^n$ 's, Theorem 1 is a genuinely symplectic result.

As above,  $(B, g)$  is a  $d$ -dimensional  $P$ -manifold,  $M = T^*B$  and  $M_r = T_r^*B$ . We denote by  $\text{Diff}^c(M)$  the group of compactly supported diffeomorphisms of  $M$ . Each  $\varphi \in \text{Diff}^c(M)$  induces a variation homomorphism

$$\text{var}_\varphi : H_*^{cl}(M) \rightarrow H_*(M), \quad [c] \mapsto [\varphi_*c - c].$$

Here, the homology  $H_*^{cl}(M)$  with closed support as well as  $H_*(M)$  are taken with integer coefficients. Notice that  $\varphi$  is not isotopic to the identity in  $\text{Diff}^c(M)$  if  $\text{var}_\varphi \neq 0$ . By Poincaré–Lefschetz duality,

$$H_*^{cl}(M) \cong H_*^{cl}(M_r \setminus \partial M_r) \cong H_*(M_r, \partial M_r) \cong H^{2d-*}(M_r) \cong H^{2d-*}(B),$$

and  $H_*(M) \cong H_*(B)$ , and so  $\text{var}_\varphi = 0$  except possibly in degree  $* = d$ . It is known from classical Picard–Lefschetz theory that  $\text{var}_\tau : H_d^{cl}(T^*S^d) \rightarrow H_d(T^*S^d)$  does not vanish, see [ArGV, p. 26]. Assume now that  $B$  is oriented. We orient the fibres  $T_x^*B$ ,  $x \in B$ , such that  $[B] \cdot [T_x^*B] = 1$ , where

the dot  $\cdot$  denotes the intersection product in homology determined by the natural orientation of the cotangent bundle  $M$ . Then  $H_d^{cl}(M) \cong \mathbb{Z}$  is generated by the fibre class  $F = [T_x^*B]$ , and  $H_d(M) \cong \mathbb{Z}$  is generated by the base class  $[B]$ , which by abuse of notation is denoted  $B$ .

PROPOSITION 2.20. *Assume that  $(B, g)$  is an oriented  $SC_k$ -manifold.*

- (i) *If  $k$  is even and  $d$  is odd,  $\text{var}_{\vartheta^m}(F) = 2mB$  for  $m \in \mathbb{Z}$ .*
- (ii) *If  $k$  is odd,  $\text{var}_{\vartheta^m} = 0$  for all  $m \in \mathbb{Z}$ .*

*Proof.* For simplicity we assume again  $m \geq 1$ . As in section 2.5 we choose  $\vartheta = \vartheta_f$ , fix  $x \in B$ , choose  $y \in W$ , and let  $\vartheta^m(T_x^*B) \cap T_y^*B = \{c_0^\pm, \dots, c_{m-1}^\pm\}$ . The local intersection number of  $\vartheta^m(T_x^*B)$  and  $T_y^*B$  at  $c_i^\pm$  is  $(-1)^{\text{ind}(c_i^\pm)}$ . Recall from Proposition 2.10 that  $\text{ind } c_0^+ = 0$  and

$$\text{ind } c_i^- = \text{ind } c_i^+ + k \quad \text{and} \quad \text{ind } c_{i+1}^+ = \text{ind } c_i^+ + k + d - 1.$$

- (i) *If  $k$  is even and  $d$  is odd, we find*

$$\vartheta_*^m(F) \cdot F = \sum_{i=0}^{m-1} (-1)^{\text{ind } c_i^+} + (-1)^{\text{ind } c_i^-} = \sum_{i=0}^{m-1} 2 = 2m,$$

and so  $\text{var}_{\vartheta^m}(F) \cdot F = \vartheta_*^m(F) \cdot F - F \cdot F = 2m$ , i.e.  $\text{var}_{\vartheta^m}(F) = 2mB$ .

- (ii) *If  $k$  is odd, we find*

$$\vartheta_*^m(F) \cdot F = \sum_{i=0}^{m-1} (-1)^{\text{ind } c_i^+} + (-1)^{\text{ind } c_i^-} = 0,$$

and so  $\text{var}_{\vartheta^m}(F) \cdot F = 0$ , i.e.  $\text{var}_{\vartheta^m}(F) = 0$ . □

Before discussing the variation homomorphism further, let us show how Proposition 2.20 (i) leads to a topological proof of Theorem 2.3 for the known odd-dimensional  $P$ -manifolds.

COROLLARY 2.21. *Assume that  $(B, g)$  is a round sphere  $S^{2n+1}$  or one of its quotients  $S^{2n+1}/G$  or a Zoll manifold  $(S^{2n+1}, g)$ . Then the conclusion of Theorem 2.3 holds true. In fact, if  $\varphi \in \text{Diff}^c(T^*B)$  is such that  $[\varphi] = [\vartheta^m] \in \pi_0(\text{Diff}^c(T^*B))$  for some  $m \in \mathbb{Z} \setminus \{0\}$ , then  $s_d(\varphi) \geq 1$ .*

*Proof.* Assume first that  $(B, g)$  is a round sphere  $S^{2n+1}$ . According to Proposition 2.1,  $(B, g)$  is an  $SC_{2n}$ -manifold, and so Proposition 2.20 (i) shows that  $\varphi_*^n(F) = 2mnB + F$  for all  $n \geq 1$ . Choose  $r < \infty$  so large that  $\varphi$  is supported in  $T_r^*B$ , choose  $x \in B$  and set  $D_x(r) = T_x^*B \cap T_r^*B$ . Then

$$\mu_{g^*}(\varphi^n(D_x(r))) \geq (2m\mu_g(B))n$$

for all  $n \geq 1$ , and so the claim follows for a round  $S^{2n+1}$ . For quotients  $S^{2n+1}/G$  the claim follows together with the argument given in Case 2

in section 2.6, and for odd-dimensional Zoll manifolds the claim follows together with the argument given in Remark 2.4.1 (i).  $\square$

We now turn to the known even-dimensional  $P$ -manifolds. Propositions 2.1 and 2.20 (ii) show that  $\text{var}_{g^m} = 0$  for  $S^{2n}$ ,  $\mathbb{C}P^n$ ,  $\mathbb{H}P^n$ ,  $\mathbb{C}aP^2$  and hence also for even-dimensional Zoll manifolds for all  $m \in \mathbb{Z}$ . For the non-orientable spaces  $\mathbb{R}P^{2n}$  and  $\mathbb{C}P^{2n-1}/\mathbb{Z}_2$  the vanishing of  $\text{var}_{g^m}$  follows from  $H_{2n}(\mathbb{R}P^{2n}) = 0$  and  $H_{4n-2}(\mathbb{C}P^{2n-1}/\mathbb{Z}_2) = 0$ . The variation homomorphism can be defined for homology with coefficients in any Abelian group  $G$ , and one checks that  $\text{var}_{g^m}$  vanishes over any finitely generated  $G$  for all the above even-dimensional  $P$ -manifolds and every  $m \in \mathbb{Z}$ . Note that if  $\text{var}_{g^m} \neq 0$  for some  $m \neq 0$  then  $\vartheta$  is not isotopic to the identity in  $\text{Diff}^c(M)$ . Since we are not aware of another obstruction we ask

QUESTION 2.22. If  $(B, g)$  is one of  $\mathbb{R}P^{2n}$ ,  $\mathbb{H}P^n$ ,  $\mathbb{C}aP^2$ ,  $\mathbb{C}P^{2n-1}/\mathbb{Z}_2$ , is then  $\vartheta$  isotopic to the identity in  $\text{Diff}^c(T^*B)$ ?

We did not ask Question 2.22 for even-dimensional Zoll manifolds or  $\mathbb{C}P^n$  in view of the following result due to Seidel and Kauffman–Krylov.

PROPOSITION 2.23. (i) *If  $(B, g)$  is  $\mathbb{C}P^n$  or a Zoll manifold of dimension 2 or 6, then  $\vartheta$  is isotopic to the identity in  $\text{Diff}^c(T^*B)$ .*

(ii) *If  $(B, g)$  is an even-dimensional Zoll manifold, then  $\vartheta^4$  is isotopic to the identity in  $\text{Diff}^c(T^*B)$ .*

*Proof.* (i) The result for  $\mathbb{C}P^n$ ,  $n \geq 1$ , has been proved in [S3] by extending the construction for  $S^2$  given in [S2]. This construction carries over literally to  $S^6$  since  $S^6$  carries an almost complex structure induced by the vector product on  $\mathbb{R}^7$  related to the Cayley numbers, see [MS1, Example 4.4]. A different proof for  $S^6$  is given in [KaK]. For other Zoll manifolds of dimensions 2 or 6, the claim follows together with the argument given in Remark 2.4.1 (i).

(ii) By (i) we can assume that  $n \geq 4$ . For  $S^n$  the claim follows from Theorem 1 and the proof of Corollary 4 in [KaK], and for arbitrary even-dimensional Zoll manifolds the claim now follows as in (i).  $\square$

REMARK 2.24. The period 4 in Proposition 2.23 (ii) is known to be minimal for “most” even dimensions  $\neq 2, 6$ . Indeed, it follows from [Br] or [DK, Proposition 6.1] and the fact that the tangent sphere bundle to  $S^{n+1}$  is not diffeomorphic to  $S^n \times S^{n+1}$  if  $n \neq 2, 6$ , that for  $n \neq 2, 6$  we have  $[\vartheta]^3 \neq \text{id}$  and hence  $[\vartheta] \neq \text{id}$  in  $\pi_0(\text{Diff}^c(T^*S^n))$ . Moreover, [Br] or [DK, Proposition 6.1] and the proof of Corollary 4 in [KaK] imply that  $[\vartheta]^2 \neq \text{id} \in \pi_0(\text{Diff}^c(T^*S^n))$  if and only if the  $(2n + 1)$ -dimensional Kervaire

sphere  $\Sigma$  is not diffeomorphic to  $S^{2n+1}$ . This is known to be the case if  $n \neq 2^i - 2$  by work of Kervaire and W. Browder, see [Ko, p. 219]. However,  $\Sigma^{29}$  is diffeomorphic to  $S^{29}$ , so that the period of  $[\vartheta] \in \pi_0(\text{Diff}^c(T^*S^{14}))$  is 2.

## References

- [AM] U. ABRESCH, W. MEYER, Injectivity radius estimates and sphere theorems, Comparison geometry (Berkeley, CA, 1993–94), Math. Sci. Res. Inst. Publ. 30, Cambridge Univ. Press, Cambridge (1997), 1–47.
- [Ar] V.I. ARNOL'D, Some remarks on symplectic monodromy of Milnor fibrations, The Floer memorial volume, Birkhäuser Progr. Math. 133 (1995), 99–103.
- [ArGV] V.I. ARNOL'D, S.M. GUSEIN-ZADE, A.N. VARCHENKO, Singularities of Differentiable Maps II, Birkhäuser Monographs in Mathematics 83 (1988).
- [B] A. BESSE, Manifolds all of Whose Geodesics are Closed, Ergebnisse der Mathematik und ihrer Grenzgebiete 93, Springer, Berlin-New York, 1978.
- [BiPS] P. BIRAN, L. POLTEROVICH, D. SALAMON, Propagation in Hamiltonian dynamics and relative symplectic homology, Duke Math. J. 119 (2003), 65–118.
- [Br] E. BRIESKORN, Beispiele zur Differentialtopologie von Singularitäten. Invent. Math. 2 (1966), 1–14.
- [CFH] K. CIELIEBAK, A. FLOER, H. HOFER, Symplectic homology II. A general construction, Math. Z. 218 (1995), 103–122.
- [DK] A. DURFEE, L. KAUFFMAN, Periodicity of branched cyclic covers, Math. Ann. 218 (1975), 157–174.
- [EHS] YA. ELIASHBERG, H. HOFER, D. SALAMON, Lagrangian intersections in contact geometry, GAFA, Geom. funct. anal. 5 (1995), 244–269.
- [F1] A. FLOER, A relative Morse index for the symplectic action, Comm. Pure Appl. Math. 41 (1988), 393–407.
- [F2] A. FLOER, The unregularized gradient flow of the symplectic action, Comm. Pure Appl. Math. 41 (1988), 775–813.
- [F3] A. FLOER, Morse theory for Lagrangian intersections, J. Differential Geom. 28 (1988), 513–547.
- [F4] A. FLOER, Witten's complex and infinite-dimensional Morse theory, J. Differential Geom. 30 (1989), 207–221.
- [FHS] A. FLOER, H. HOFER, D. SALAMON, Transversality in elliptic Morse theory for the symplectic action, Duke Math. J. 80 (1995), 251–292.
- [FrS1] U. FRAUENFELDER, F. SCHLENK, Hamiltonian dynamics on convex symplectic manifolds, math.SG/0303282.

- [FrS2] U. FRAUENFELDER, F. SCHLENK, Slow entropy and symplectomorphisms of cotangent bundles, math.SG/0404017.
- [FuOOO] K. FUKAYA, Y.-G. OH, H. OHTA, K. ONO, Lagrangian intersection Floer theory: Anomaly and obstruction, preprint, Kyoto University (2000).
- [GT] D. GILBARG, N. TRUDINGER, Elliptic Partial Differential Equations of Second Order, second edition, Grundlehren der Mathematischen Wissenschaften 224, Springer, Berlin, 1983.
- [GrG] D. GROMOLL, K. GROVE, On metrics on  $S^2$  all of whose geodesics are closed, Invent. Math. 65 (1981/82), 175–177.
- [HZ] H. HOFER, E. ZEHNDER, Symplectic Invariants and Hamiltonian Dynamics, Birkhäuser, Basel, 1994.
- [KT] A. KATOK, J.P. THOUVENOT, Slow entropy type invariants and smooth realization of commuting measure-preserving transformations, Ann. Inst. H. Poincaré Probab. Statist. 33 (1997), 323–338.
- [KaK] L. KAUFFMAN, N. KRYLOV, Kernel of the variation operator and periodicity of open books, Topology Appl. 148 (2005), 183–200.
- [KhS] M. KHOVANOV, P. SEIDEL, Quivers, Floer cohomology, and braid group actions, J. Amer. Math. Soc. 15 (2002), 203–271.
- [Ko] A. KOSINSKI, Differential Manifolds, Pure and Applied Mathematics 138, Academic Press, Inc., Boston, MA, 1993.
- [MS1] D. MCDUFF, D. SALAMON, Introduction to Symplectic Topology, second edition, Oxford Mathematical Monographs, The Clarendon Press, Oxford University Press, New York, 1998.
- [MS2] D. MCDUFF, D. SALAMON,  $J$ -Holomorphic Curves and Symplectic Topology, AMS Colloquium Publications 52, AMS, Providence, RI, 2004.
- [O1] Y.-G. OH, Floer cohomology of Lagrangian intersections and pseudo-holomorphic disks, I, Comm. Pure Appl. Math. 46 (1993), 949–993.
- [O2] Y.-G. OH, On the structure of pseudo-holomorphic discs with totally real boundary conditions, J. Geom. Anal. 7 (1997), 305–327.
- [P1] L. POLTEROVICH, Growth of maps, distortion in groups and symplectic geometry, Invent. Math. 150 (2002), 655–686.
- [P2] L. POLTEROVICH, Slow symplectic maps, continued fractions, and related stories, Symplectic and Contact Topology: Interactions and Perspectives (Toronto, ON/Montreal, QC, 2001), Fields Inst. Commun. 35, Amer. Math. Soc., Providence, RI (2003), 165–173.
- [RS] J. ROBBIN, D. SALAMON, Asymptotic behaviour of holomorphic strips, Ann. Inst. H. Poincaré Anal. Non Linéaire 18 (2001), 573–612.
- [S] D. SALAMON, Lectures on Floer homology, Symplectic Geometry and Topology (Park City, UT, 1997), IAS/Park City Math. Ser. 7, Amer. Math. Soc., Providence, RI (1999), 143–229.
- [Sc] M. SCHWARZ, Morse Homology, Birkhäuser Progress in Mathematics 111, (1993).

- [S1] P. SEIDEL, Symplectic automorphisms of  $T^*S^2$ , math.DG/9803084.
- [S2] P. SEIDEL, Lagrangian two-spheres can be symplectically knotted, *J. Differential Geom.* 52 (1999), 145–171.
- [S3] P. SEIDEL, Graded Lagrangian submanifolds, *Bull. Soc. Math. France* 128 (2000), 103–149.
- [S4] P. SEIDEL, Vanishing cycles and mutation, *European Congress of Mathematics, Vol. II (Barcelona, 2000)* Birkhäuser Progr. Math. 202 (2001), 65–85.
- [S5] P. SEIDEL, More about vanishing cycles and mutation, *Symplectic Geometry and Mirror Symmetry (Seoul, 2000)*, World Sci. Publishing, River Edge, NJ (2001), 429–465.
- [S6] P. SEIDEL, Fukaya categories and deformations, *Proceedings of the International Congress of Mathematicians, Vol. II (Beijing, 2002)*, Higher Ed. Press, Beijing (2002), 351–360.
- [S7] P. SEIDEL, A long exact sequence for symplectic Floer cohomology, *Topology* 42 (2003), 1003–1063.
- [S8] P. SEIDEL, Lectures on four-dimensional Dehn twists, math.SG/0309012.
- [S9] P. SEIDEL, Homological mirror symmetry for the quartic surface, math.SG/0310414.
- [ST] P. SEIDEL, R. THOMAS, Braid group actions on derived categories of coherent sheaves, *Duke Math. J.* 108 (2001), 37–108.
- [Sh] M. SHUB, Dynamical systems, filtrations and entropy, *Bull. Amer. Math. Soc.* 80 (1974), 27–41.
- [V] C. VITERBO, Functors and computations in Floer homology with applications. I, *GAFA, Geom. funct. anal.* 9 (1999), 985–1033.
- [W] A.W. WADSLEY, Geodesic foliations by circles, *J. Differential Geom.* 10 (1975), 541–549.
- [Wo] J. WOLF, *Spaces of Constant Curvature*, fifth edition. Publish or Perish, Inc., Houston, TX, 1984.
- [Z] E. ZEHNDER, Note on smoothing symplectic and volume-preserving diffeomorphisms, *Springer Lecture Notes in Math.* 597 (1977), 828–854.

U. FRAUENFELDER, Department of Mathematics, Hokkaido University, Sapporo 060-0810, Japan  
urs@math.sci.hokudai.ac.jp

F. SCHLENK, Mathematisches Institut, Universität Leipzig, 04109 Leipzig, Germany  
schlenk@math.uni-leipzig.de

Received: April 2004  
Revision: June 2004  
Accepted: October 2004