

Pulsed fiber laser using micro-electro-mechanical mirrors

Yves-Alain Peter
Hans Peter Herzig
Etienne Rochat
René Dändliker, MEMBER SPIE
Cornel Marxer
Nicolaas F. de Rooij
University of Neuchâtel
Institute of Microtechnology
rue A.-L. Breguet 2
CH-2000 Neuchâtel
Switzerland
E-mail: yves-alain.peter@imt.unine.ch

Abstract. Two different types of micromirrors are integrated with a fiber laser to modulate the cavity Q -factor. Both systems operate at frequencies up to 60 kHz and generate a pulse peak power 100 times higher than the continuous emission. We simulate the emitted pulses and find a good agreement with the measured value for the period of relaxation oscillations. The simulations also show the necessity of a shorter rise time of the Q -factor modulation to achieve one single giant and narrow Q -switched pulse.

Subject terms: fiber lasers; neodymium lasers; modulators; mirrors; switching; pulses.

1 Introduction

Recently, micro-optical and microelectromechanical technologies have been highlighted. Because of their potential for batch processing and inexpensive replication, these technologies are merging to create a new and broader class of micro-optoelectromechanical (MOEM) devices.

The development of commercial devices such as torsional mirrors, laser scanners, optical shutters and dynamic micromirror displays will benefit from this new technology.¹

The goal of this paper is to study the use of micromirrors in a switchable optomechanical system. For that purpose, we built a compact pulsed fiber laser with a microelectromechanical (MEM) element (torsional micromirror or vertical mirror) acting as one of the two reflectors of the cavity and as the switching element. To generate a pulse in a conventional Q -switched fiber laser, a modulator (acousto-optic, electro-optic or mechanical) must be introduced into the cavity.² In our configuration, no additional elements are needed; the modulator is the reflector itself, thus we can build an all fiber laser with a closed and compact cavity. Moreover, it has the potential of integration in a compact microsystem.

2 Fiber Laser

Figure 1 shows the setup of the pulsed fiber laser. The fiber laser is based on a 120 mm long Nd^{3+} doped fiber. The cavity consists of the switchable micromirror (torsional or vertical) described in Section 3 and a Bragg grating with 48% reflectivity and 0.1 nm bandwidth at 1071 nm, which is still inside the fluorescence spectrum of neodymium in silica. The laser fiber is spliced to a wavelength division multiplexing (WDM) coupler, enabling us to use the Bragg grating as an output reflector, while pumping through it. The pump source is a 150 mW GaAlAs laser diode emitting at 810 nm. For this configuration and with the torsional micromirror, we measured a laser threshold of 3 mW and a

slope efficiency of 19% (see Fig. 2). These results are in good agreement with the values commonly reported in the literature.³

3 Micromechanical Mirrors

Two types of micromechanical mirrors were fabricated. The first is a torsional mirror and the second is a vertical mirror.

The torsional micromirror has an area of $50 \times 70 \mu\text{m}^2$ and is fabricated by polysilicon surface micromachining.⁴ The rectangular mirror has a torsional suspension beam in the middle and two electrodes (address and landing) placed underneath (Fig. 3). The torsional micromirror is covered with $0.2 \mu\text{m}$ of aluminum to improve its reflectivity to typically 75%. When a voltage of 35 V is applied to the address electrode, the electrically grounded mirror rotates by an angle of 2.6 deg and hits the landing electrode. The SEM of Fig. 3(b) shows such a mirror, which is one element of an array of 20×20 torsional micromirrors.

The vertical mirror has an area of $75 \times 100 \mu\text{m}^2$ (Fig. 4). It is fabricated by deep anisotropic reactive ion etching.⁵ The vertical mirror moves along the optical axis driven by two comb actuators. The displacement of the mirror is typically $5 \mu\text{m}$ with an applied voltage of 40 V and frequencies up to 60 kHz. The vertical micromirror is covered with $0.2 \mu\text{m}$ of aluminum to improve its reflectivity, which was measured to be 65%. The SEM of Fig. 4 shows such a mirror with its two comb actuators and the U-groove for receiving the fiber.

4 Results

Experimentally, the fiber is first placed close to the mirror with a slight air gap. Then, the micromirrors are actuated at frequencies up to 60 kHz to produce a modulation of the resonator losses. Finally, we adjust the fiber-mirror distance and alignment to optimize the output signal of the pulsed laser. In such a configuration, we were able to achieve pulses up to 200 mW, which is about 100 times higher than

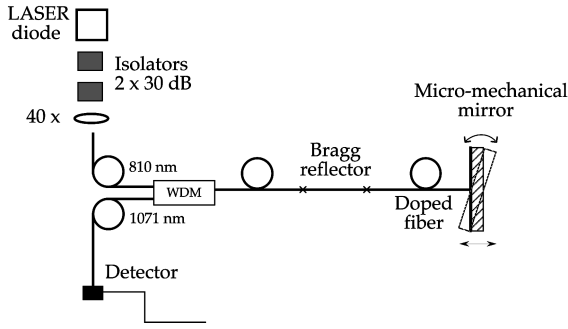

Fig. 1 Schematic diagram of the pulsed fiber laser system.

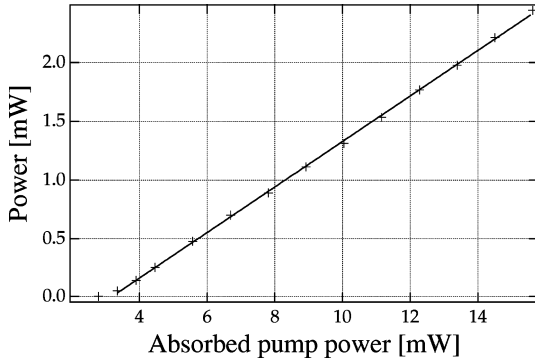

Fig. 2 Measured characteristics of the cavity: output power versus absorbed pump power. The laser threshold is $P_{th}=3$ mW and the slope efficiency is 19%.

the continuous emission. Figure 5(a) shows a typical output train obtained with the torsional mirror at 20 kHz modulation. If the mirror is operated at lower frequencies, we observe multiple pulses. Figure 5(b) shows such pulses separated by $25 \mu\text{s}$ and obtained with the torsional mirror modulated at 7 kHz. These multiple pulses are thought to be generated by the mechanical relaxation oscillations of the mirror, as described by Jaecklin et al.⁶ Figure 6 shows the results obtained with the vertical mirror. For a repetition rate of $f=16$ kHz, a single pulse per switching period is obtained. The enlarged view in Fig. 6(b) of one individual pulse indicates a pulse width of $2 \mu\text{s}$ with a superposed modulation of about 350 ns period.

Both types of mirrors give typically similar pulses. Nevertheless, the vertical mirror system showed a better stability compared with the torsional micromirror system. This is due to the integration of the fiber holder and the mirror on the same chip making the whole system more compact.

5 Simulations

To investigate the behavior of our device, we simulated the generated pulses by using the rate equations of the fiber laser⁷

$$\frac{dN}{dt} = P_p - \frac{N(t)}{\tau} - N(t)\eta(t)\sigma c \quad (1)$$

and

$$\frac{d\eta}{dt} = N(t)\eta(t)\sigma c - \eta(t)\beta(t)c + \frac{\Omega}{4\pi} \frac{N(t)}{\tau}, \quad (2)$$

where P_p is the pump density, $N(t)$ is the population inversion, τ is the fluorescent lifetime, $\eta(t)$ is the photon density, σ the transition cross section, c is the speed of light, $\beta(t)$ is the resonator losses and Ω is the diffraction limited solid angle of the fundamental mode. With the pump wavelength $\lambda_p=810$ nm, the diameter $\phi_{core}=2.8 \mu\text{m}$ of the core, the length $l_{fiber}=120$ mm of the fiber

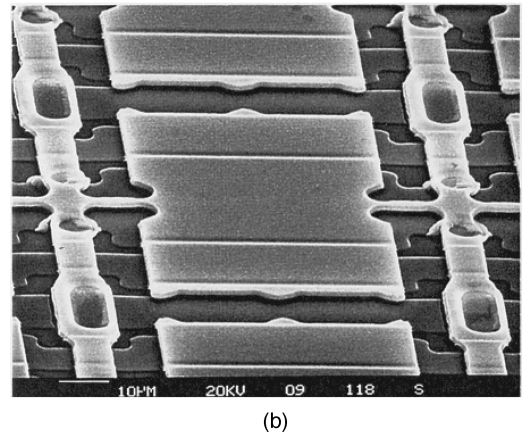
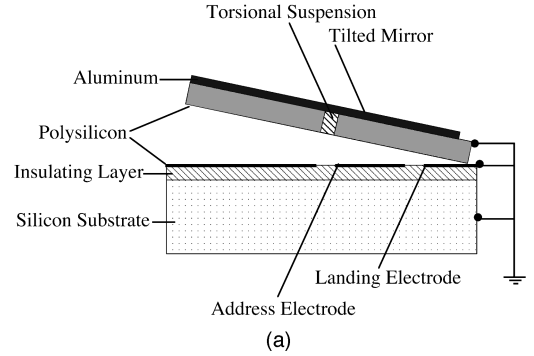

Fig. 3 (a) Schematic drawing of the cross section of the micromirror and (b) top view scanning electron micrograph (SEM) of a torsional micromirror without metallization.

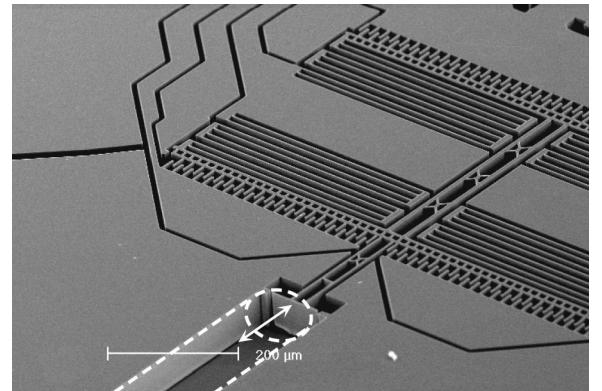
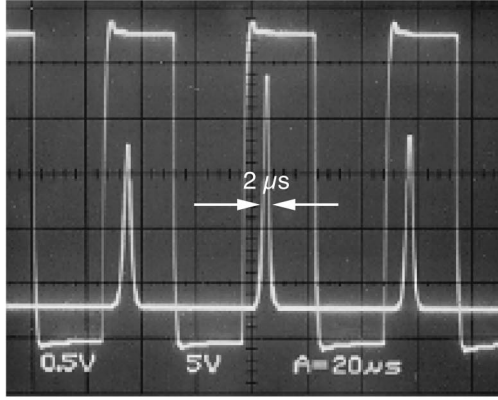
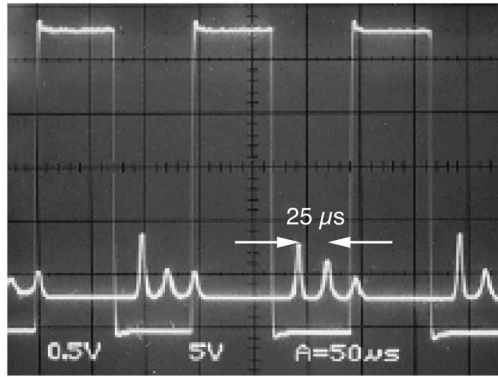

Fig. 4 Top view (SEM) of the vertical mirror with the comb actuators and the fiber (dashed drawn) in the U-groove.



(a)



(b)

Fig. 5 (a) Pulse train obtained with the torsional mirror for repetition rate $f=20$ kHz and pump power $P=15.8$ mW and (b) multiple-pulse train obtained with the torsional mirror for repetition rate $f=7$ kHz and pump power $P=15.8$ mW.

and the measured coupled power $P_{\text{cpl}} \approx 10$ mW, we get for the volume of the cavity $V \approx 7.4 \times 10^{-7}$ cm³ and for the pump density $P_p = P_{\text{cpl}} \lambda_p / hcV \approx 5.5 \times 10^{22}$ cm⁻³. With the emission wavelength $\lambda = 1071$ nm, the refractive index $n = 1.5$ and the area of the core $A = 6 \times 10^{-8}$ cm² we get for the diffraction limited solid angle of the fundamental mode $\Omega = \lambda^2 / n^2 A = 0.08$ sr. We measured the fluorescence spectrum and, with the Fuchtbauer-Ladenberg method,⁸ we obtained for the emission cross section $\sigma \approx 1.4 \times 10^{-20}$ cm². The value $\tau \approx 500$ μ s for the fluorescent lifetime was determined by measuring the frequency transfer function between pump light and fluorescence.⁹

With the mirror in the on position, we measured a laser threshold pump power of $P_{\text{th}} \approx 3$ mW (Fig. 2). The losses β_{th} can be estimated from the average reflectivity R of the two mirrors and the fiber length l_{fiber} of the laser through the relation

$$\beta_{\text{th}} = \frac{-\ln R}{l_{\text{fiber}}}. \quad (3)$$

With $R=65\%$ and $l_{\text{fiber}}=120$ mm we get $\beta_{\text{th}}=3$ m⁻¹. The corresponding population inversion N_{th} is then obtained from

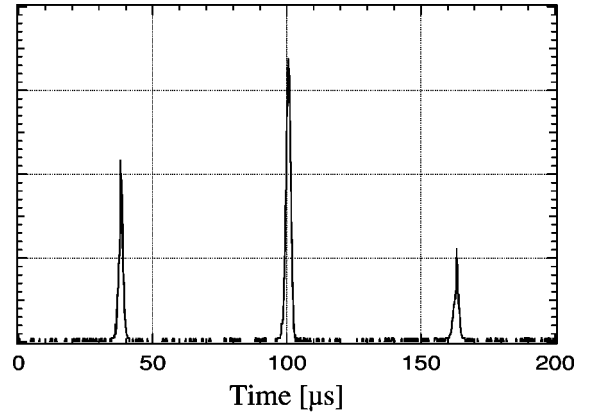

(a)

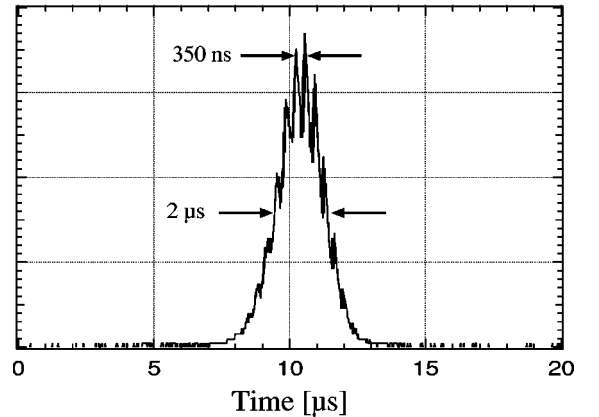

(b)

Fig. 6 (a) Pulse train obtained with the vertical mirror for repetition rate $f=16$ kHz and (b) enlarged view of an individual pulse.

$$\beta_{\text{th}} = N_{\text{th}} \sigma. \quad (4)$$

The initial population inversion N_i for a given coupled pump power P_{cpl} , with the mirror in the off-position, is related to N_{th} by

$$\frac{N_i}{N_{\text{th}}} = \frac{P_{\text{cpl}}}{P_{\text{th}}}. \quad (5)$$

For $P_{\text{cpl}} \approx 10$ mW and with $\sigma = 1.4 \times 10^{-20}$ cm² we get finally $N_{\text{th}} = 3 \times 10^{18}$ cm⁻³ and $N_i = 8 \times 10^{18}$ cm⁻³.

Eqs. (1) and (2) can now be solved numerically. Figure 7 shows the population inversion $N(t)$ and the photon density $\eta(t)$ during one switching period. We assume that the losses are switched linearly from the initial high to the final low value ($\beta_{\text{initial}} = N_i \sigma = 11$ m⁻¹ and $\beta_{\text{min}} = \beta_{\text{th}} = 3$ m⁻¹) with different rise times: 5 μ s for Fig. 7(a) and 2 μ s for Fig. 7(b).

The typical width of the simulated peak is 40 ns. The relaxation time is typically $T_{\text{relax}} \approx 320$ ns for 5 μ s switching time [Fig. 7(a)] and 200 ns for 2 μ s switching time [Fig. 7(b)]. If we consider Fig. 7(b), we can see that reducing the switching time from 5 to 2 μ s leads to a reduced number of peaks, which are also higher. Thus, if we want to get one giant and narrow pulse (one real Q-switched pulse),

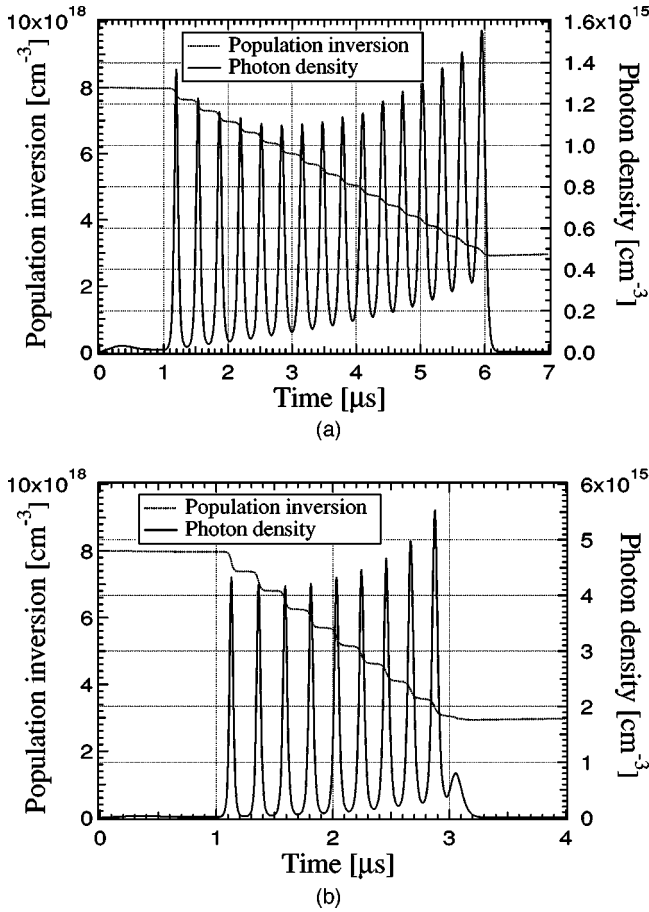

Fig. 7 Simulation of pulses with $\beta_{\max}=11\text{ m}^{-1}$ and $\beta_{\min}=3\text{ m}^{-1}$ where the rise times of the quality factor are (a) $5\text{ }\mu\text{s}$ and (b) $2\text{ }\mu\text{s}$.

we require shorter switching times, of the order of 100 ns. The numerical simulations also showed that the spontaneous emission terms $N(t)/\tau$ in Eqs. (1) and (2) cannot be neglected in this regime. The expected peak power of the pulse can be calculated from

$$P_{\text{pulse}} = \eta_{\text{pulse}} h \frac{c^2}{\lambda} \pi \left(\frac{\phi_{\text{core}}}{2} \right)^2. \quad (6)$$

With $\eta_{\text{pulse}}=1.6 \times 10^{15}\text{ cm}^{-3}$ [from Fig. 7(a)], we get $P_{\text{pulse}} \approx 500\text{ mW}$. The measured value of the period of relaxation oscillations, which is 350 ns [Fig. 6(b)] and is in good agreement with that obtained from the simulation shown in Fig. 7(b), which is 320 ns.

6 Conclusions

We demonstrated a pulsed fiber laser using two different types of micromechanical mirrors, a torsional micromirror and a vertical mirror. To generate real Q -switching pulses (single giant pulses with narrow widths), we should have shorter switching times. Nevertheless, the technology for the fabrication of the mirrors is compatible with the fabrication of other micro-optical elements, such as microlenses, fan-out and fan-in elements,¹⁰ which enables the realization

of compact microsystems. Arrays of pulsed lasers can be combined with arrays of micro-optical elements to form highly parallel optical networks.

Acknowledgments

The authors are thankful to J. P. Dan, G. Kotrotsios, V. Neuman and H. Berthou of the CSEM Neuchâtel for fabricating the doped fiber and to Dr. H. Limberger of the Swiss Federal Institute of Technology, Lausanne (EPFL) for manufacturing the Bragg grating. The project was supported by the Swiss priority programs OPTIQUE II and MINAST.

References

1. M. Motamedi and L. Beiser, Eds., *Micro-optics/Micromechanics and Laser Scanning and Shaping*, Proc. SPIE **2383** (1995).
2. W. Barnes, "Q-switched fiber lasers," in *Rare Earth Doped Fiber Lasers and Amplifiers*, M. Dignonnet, Ed., pp. 375–391, Marcel Dekker, New York (1993).
3. W. Lüthy and H. P. Weber, "High-power monomode fiber lasers," *Opt. Eng.* **34**, 2361–2364 (1995).
4. V. P. Jaecklin, C. Linder, N. de Rooij, J.-M. Moret, and R. Vuilleumier, "Optical microshutters and torsional micromirrors for light modulator arrays," in *Tech. Dig. IEEE Micro Electro Mech. Syst. Workshop*, pp. 124–127 (1993).
5. C. Marxer, M.-A. Gretillat, O. Anthamatten, R. Baettig, B. Valk, P. Vogel, and N. F. de Rooij, "Vertical mirrors fabricated by deep reactive ion etching for fiber-optic switching applications," *J. Microelectromech. Syst.* **6**, 277–285 (1997).
6. V. P. Jaecklin, C. Linder, N. de Rooij, J.-M. Moret, and R. Vuilleumier, "Line-addressable torsional micromirrors for light modulator arrays," *Sens. Actuators A* **41–42**, 324–329 (1994).
7. A. Yariv, "Theory of laser oscillations and its control in the continuous and pulsed regimes," in *Optical Electronics in Modern Communications*, Chap. 6, pp. 185–241, Oxford University Press, New York (1997).
8. W. L. Barnes, P. Morkel, and J. Townsend, "Detailed characterization of Nd^{3+} doped $\text{SiO}_2\text{-GeO}_2$ glass fibre lasers," *Opt. Commun.* **82**, 282–288 (1991).
9. J. Morel, A. Woodtli, and R. Dändliker, "Characterization of the fluorescent lifetime of doped fibers by measuring the frequency transfer function," *J. Lightwave Technol.* **14**, 739–742 (1996).
10. H. P. Herzig, Ed., *Micro-Optics*, Taylor & Francis, London (1997).



Yves-Alain Peter received his diploma in physics from the University of Neuchâtel, Switzerland, in 1994. In 1995, he was a scientific collaborator with the Medical Radiobiology Department of the Paul Scherrer Institute in Villigen, Switzerland, and joined the Applied Optics Group at the Institute of Microtechnology of the University of Neuchâtel, Switzerland, as a PhD student. His current research interests are the micro-optoelectromechanical systems with applications in optical switching. Mr. Peter is member of IEEE/LEOS, OSA and the Swiss Physical Society.

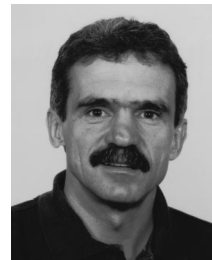

Hans Peter Herzig received his diploma in physics from the Swiss Federal Institute of Technology in Zürich, Switzerland, in 1978. From 1978 to 1982 he was a scientist with the Optics Development Department of Kern in Aarau, Switzerland, working in lens design and optical testing. In 1983, he became a graduate research assistant with the Applied Optics Group at the Institute of Microtechnology of the University of Neuchâtel, Switzerland, working in the field of holographic optical elements, especially scanning elements. In 1987, he received his PhD degree in optics. He currently heads the micro-optics research group and is a Privat-Docent at the University of Neuchâtel. Dr. Herzig is member of OSA and EOS and a board member of the Swiss Society of Optics and Microscopy.



Etienne Rochat received his engineering diploma in microtechnology from the Swiss Technical College, Yverdon, in 1991 and his engineering degree in microtechnology from the Swiss Federal Institute of Technology, Lausanne, in 1995. He is currently a PhD candidate with the Institute of Microtechnology, University of Neuchâtel. His research interests include rare-earth doped fiber sources for sensors application and doped fiber power amplifiers for coherent space communication systems.

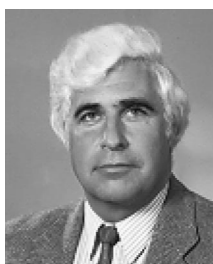

René Dändliker received his diploma in physics from the Swiss Federal Institute of Technology, Zürich, in 1963, his PhD in physics from the University of Berne, Switzerland, in 1968, and the Venia Legendi for applied physics from the Swiss Federal Institute of Technology, Zürich, in 1978. From 1963 to 1969 he was a graduate research assistant with the Institute of Applied Physics, University of Berne, working on gas and solid state lasers. From 1969 to

1970 he was a research scientist with the Philips Research Laboratories, Eindhoven, Netherlands, working in the field of applied optics. From 1970 to 1978 he was a senior scientist and head of the Coherent Optics Group at the Brown Boveri Research Center, Baden, Switzerland, where he was concerned with optical metrology applied to mechanics, such as laser Doppler velocimetry and heterodyne holographic interferometry. Since 1978 he has been a professor of applied optics with the University of Neuchâtel, Switzerland, and since 1989 also a professor of applied optics with the Swiss Federal Institute of Technology, Lausanne. His current research activities are in optical metrology, optical fibers and sensors, holography and optical computing, diffractive optical elements and micro-optics. Dr. Dändliker was president of the European Optical

Society from 1994 to 1996 and he is a vice-president of the International Commission for Optics, a fellow of the OSA and the Swiss Academy of Engineering Sciences, a member of the SPIE, the French Society of Optics, the German Society of Applied Optics, and the European Physical Society, and an affiliate of LEOS/IEEE.



Cornel Marxer received his diploma in microtechnology from the Swiss Federal Institute of Technology, Lausanne, in 1994 and his PhD from the University of Neuchâtel in 1997. Since 1994 he has been with the Institute of Microtechnology (IMT) at the University of Neuchâtel, Switzerland, where he has been a research and teaching assistant with the group of Prof. de Rooij. His research interests are novel silicon micro-machined actuators for optical applications

and reliability testing of micromechanical systems.



Nicolaas F. de Rooij received his PhD degree from Twente University of Technology, Netherlands, in 1978. From 1978 to 1982, he was with the Research and Development Department of Cordis Europa N.V., Netherlands. In 1982, he became a professor with the Institute of Microtechnology of Neuchâtel (IMT), Switzerland, and headed the Sensors, Actuators and Microsystems Laboratory. From October 1990 to October 1996 he directed the IMT. Since

1987, he has been a lecturer with the Swiss Federal Institute of Technology, Zurich, and since 1989, he has also been a professor at the Swiss Federal Institute of Technology, Lausanne. His research activities include microfabricated sensors, actuators and microsystems.