

Change detection in range imaging for 3D scene segmentation

Christian Schutz and Heinz Hugli

University of Neuchatel, Institute of Microtechnology
Tivoli 28, CH-2003 Neuchatel, Switzerland
schutz@imt.unine.ch, hugli@imt.unine.ch

ABSTRACT

This paper deals with the problem of segmenting a 3D scene obtained by range imaging. It assumes scenes of arbitrary complexity in which the objects to be recognized are newly added or removed and investigates how the methods of change detection and image difference used in classical image processing can be used in range imaging.

In a first step, we consider the case of ideal range images and conduct an analysis of segmentation by range image difference that shows the direct applicability of this principle. In a second step, we consider the case of the wide class of range sensors that suffer from shadowing effects which leads to missing data in the range image. An interpretation of this ambiguity in difference calculation and means to remove it will be given. Additional rules for the practical segmentation of 3D scenes by range image change detection are described.

The presented methods lead to the possibility to segment a scene by isolating newly added or removed objects. They are tested using range images from two distinct range imagers of the light stripping type. Results indicate the success of this approach and the practical possibility to use it in the frame of an assembly task.

KEYWORDS: segmentation, change detection, range imaging, free-form 3D object recognition

1. INTRODUCTION

The work in this paper addresses the segmentation problem of a 3D scene obtained by range imaging. A typical 3D scene considered consists of free-form objects, possibly occluding one another, lying on a complex 3D background as shown for example in Fig. 1. Furthermore, the objects and the background may be of different texture and color. The vision task to perform is to isolate a particular object, newly added or removed. This will, for example, allow a robot to locate and grasp the object in the 3D scene.



Fig. 1 Complex 3D scene to segment

The segmentation of a 3D scene into the objects it contains is a task which difficulty increases with increasing scene complexity. Simple thresholding methods are not sufficient when objects are not clearly separated from each other or from their environment. Only isolated objects lying on a simple background can be segmented that way. Segmentation methods based on region homogeneity must also be abandoned when the objects are arbitrary-shaped, with no chance to find simple object primitives nor an adequate homogeneity function to propose. Only objects made of simple edges or patches can be successfully segmented. Methods based on visual attention⁷ are not satisfactory either.

A possibility to escape this difficulty and to allow complex scenes uses image sequences. Rather than analyzing each image separately, it proceeds iteratively by detecting objects as they are moved in the 3D environment, keeping track of the previous objects as they are moved⁴. With it, the task becomes simpler just because one or only few objects must be detected at once.

Another potential advantage of this method is the possibility to find the objects by change detection. Change detection refers to the possibility to combine two successive images in order to find changes in the scene like objects added or removed from the scene. Widely used in quality control and motion detection, change detection often applies a simple difference of the two images⁸. Other combination rules have been proposed, as in remote sensing and medical applications².

Despite a wide use in intensity imaging, change detection has not found its way to range imaging. To our knowledge, the problem of change computation in presence of real range images has not been addressed in the literature.

In fact, there is a basic interest for detecting changes in range imaging. The motivation is related to the geometric nature of range imaging which results in measurements that reflect an intrinsic property of an object. Range differences are believed to be more stable than differences of the related intensity images.

Obviously change detection can only be applied to images where changes happen. To isolate an object from a complex background, at least two scene acquisitions are needed; before and after the object is moved. This is not a real limitation for the assembly task considered, since the addition of objects to a robots workspace is usually under control.

The paper is structured as follows: Section 2 introduces the basic change calculation principle and its application to range images. Rules to deal with non-valid points in range images are developed in section 3. Section 4 shows results for a series of range images acquired by different range sensors and finally section 5 concludes the work.

2. RANGE IMAGE CHANGE DETECTION

Multiple image acquisitions of a scene, before and after object changes, allow easy change detection by calculating the difference of two successive acquisitions. The difference calculation can be interpreted as a high-pass filter which extracts image regions undergoing temporal changes. An important decision is the selection of the physical value, e.g. intensity or color, to be used for difference calculation. It should allow to interpret reliably the circumstance which caused the changes.

Range is a promising measure since it is an explicit representation of the scene geometry. Range images measure the depth of a scene and changes are easily detectable.

Objects have a certain volume and their addition/removal to/from a scene results in significant difference in the range images which also permits reliable object detection. An object is detected if the change exceeds a certain threshold. Positive change values indicate a new object, whereas negative values indicate object removal. This leads to the following change labeling scheme:

$$\begin{aligned}
 d &= r_1 - r_0 \\
 \tau &\text{ threshold} \\
 \text{label} &= \begin{cases} \oplus & \text{"new object"} & d > \tau \\ \ominus & \text{"removed object"} & d < -\tau \\ \omin� & \text{"unchanged"} & -\tau \leq d \leq \tau \end{cases}
 \end{aligned} \tag{1}$$

The basic range change principle is explained with the following cube configurations shown in Fig. 2.

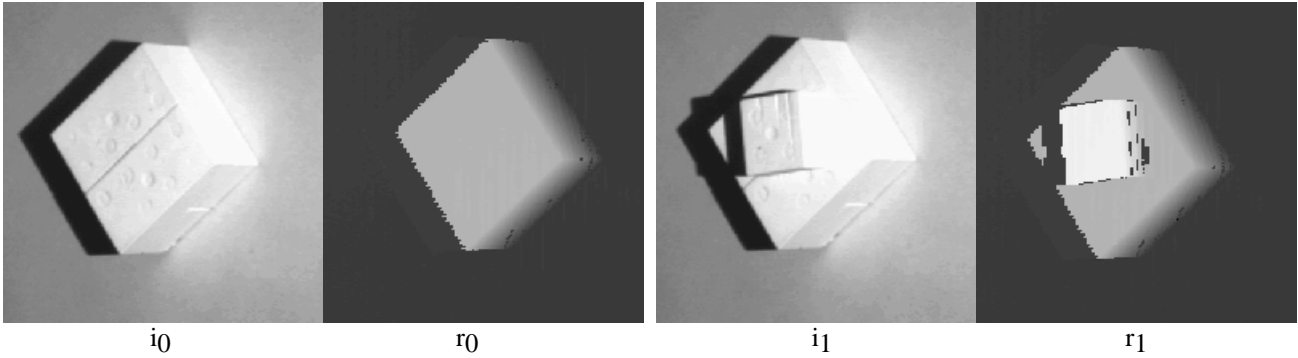

Fig. 2 Intensity (i) and range (r) images of successive scenes 0 and 1

Both cubes have the same color which results in little intensity change and object segmentation by intensity change detection becomes difficult, whereas the difference in range is of significant amount (Fig. 3). The range change image shown in Fig. 4 is calculated by subtracting the current image r_1 from the previous r_0 . Corresponding pixels to subtract have the same image array indices, because it is assumed that the camera has not moved in-between the different acquisitions and therefore no geometric matching of the images is necessary. Since a range image represents a perspective view, the 3D differences do not indicate the absolute dimensions of an object.

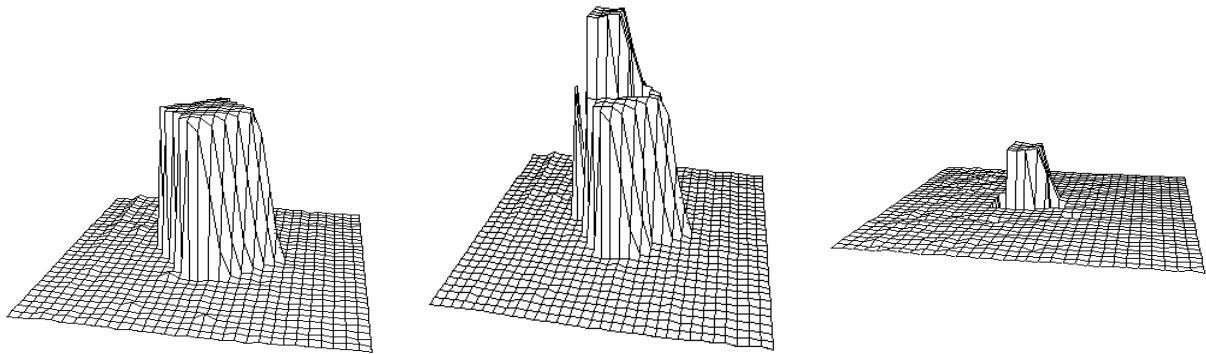

Fig. 3 Range images of the scenes shown in Fig. 2 and range change image plotted as surface graphs

Fig. 4 shows the range change image and the resulting "new object" region superimposed to the range image r_1 .

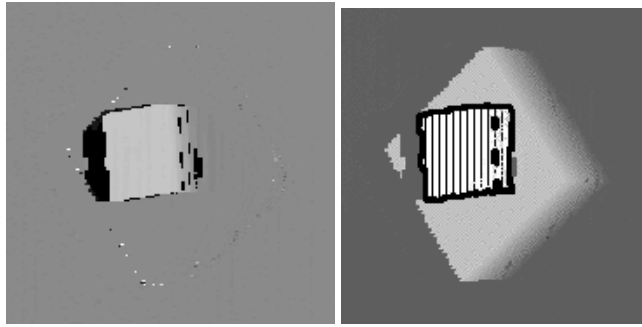

Fig. 4 Range change image and "new object" region

3. SHADOW CONTROLLING

Real range images contain pixels with an invalid range value. This fact is bound to the acquisition device. Range finders working on the triangulation principle encounter this problem⁶. Since the light source and the camera form a triangle, they do not see the scene from the same view angle. The camera picture may contain pixels not illuminated by the light source: i.e., objects may be hidden by shadows and thus cannot be measured. Moreover, the object color has an influence on the measurement process. Black objects do not reflect the light and remain unseen in the image. (This fact is sometimes used for background rejection where the object support is covered by a black sheet and easily extracted in the range image by filtering the non-valid pixels.)

Non-valid pixels caused by shadows and dark objects will be given the term shadow. Fig. 5 compares the ideal and real range image of the same object. The first one has been calculated with rendering software, so every pixel has a valid range value. The second is from a real range imager and exhibits typical invalid values shown as "holes". It was obtained by a BIRIS range finder which operates on the triangulation principle and thus generates invalid values at pixels covered by shadows¹¹.

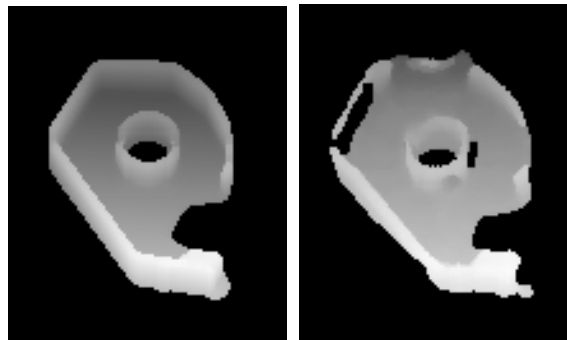

Fig. 5 Ideal and real range image of the same object

The labeling according to Eq. 1 applies well to ideal range images. However, the possibility that invalid range values may appear in range images, imposes a new definition of the difference calculation in Eq 1. Changes between two range images can only be calculated for valid pixels.

A new labeling scheme is necessary when calculating the difference between valid and non-valid pixels. It has to consider the four possible cases which may appear in the comparison of valid or non-valid values of two successive range images r_0 and r_1 . The case (valid, valid) refers to the case of an ideal range image: it is solved by Eq. 1. The case (non-valid, non-valid) refers to a situation without any measurements and is solved by giving the label "undefined". The remaining cases (valid, non-valid) and (non-valid, valid) receive the labels "new shadow" and "removed shadow" respectively. A first labeling is proposed according the following rule:

$$\text{label} = \begin{cases} \oplus \ominus \ominus \text{ (Eq. 1)} & \text{if } (r_0, r_1) = \\ \circ & \text{"removed shadow" (non-valid, valid)} \\ \bullet & \text{"new shadow" (valid, non-valid)} \\ \emptyset & \text{"undefined" (non-valid, non-valid)} \end{cases} \quad (2)$$

The following case study shown in Fig. 6 illustrates the application of the new labeling scheme to a scene where objects are added and removed.

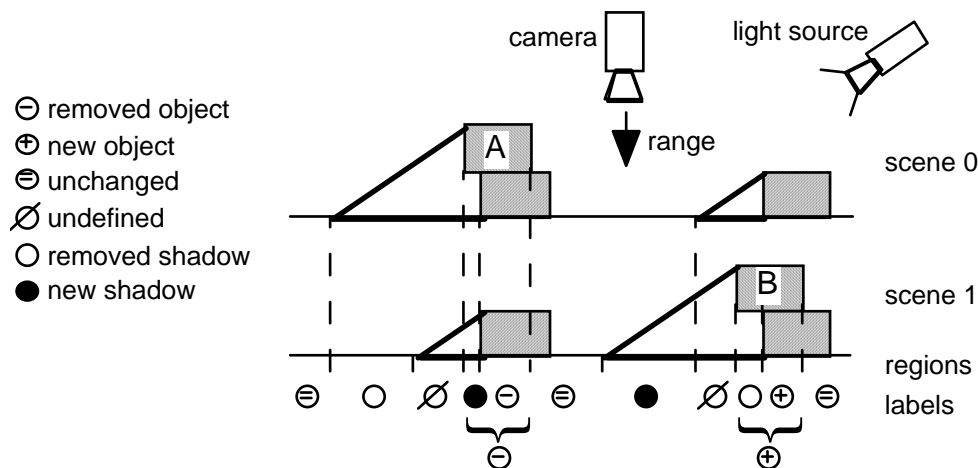

Fig. 6 Different range change labels for a case study

The illustration in Fig. 6 shows that the labeling according Eq. 2 is not fully correct. The regions of "new objects" and "removed objects" represent not completely the correct dimensions of the objects A and B. In fact, there exists some ambiguity for the "new shadow" and "removed shadow" which has to be solved after the labeling. In the case of "new shadow" the dilemma occurs, because it is not possible to determine if a "new shadow" has been added because a nearby added object casts a new shadow (B) or if an object has been removed (A). Similarly, "removed shadow" may be the result of a nearby removed object (A) or a new object (B) covering a shadow.

A heuristic solution is proposed to solve this dilemma. It is inspired by the two cases A and B presented in Fig. 6. We notice that a "new shadow" connected to a "removed object" region represents a part of the "removed object". Therefore, the complete object region A results out of the fusion of the connected "new shadow" and "removed object" regions as illustrated in Fig. 6. A similar case occurs for object B, where the "removed shadow" connected to the "new object" is added to the latter one to complete the object region. Formally, the "new shadow" and "removed shadow" regions are relabeled in a second step according to the following rules:

$$\forall \text{"removed shadow"}: \text{new label} = \begin{cases} \text{"new object"} & \text{if "removed shadow" is connected to a "new object"} \\ \text{"removed shadow"} & \text{otherwise} \end{cases} \quad (3)$$

$$\forall \text{"new shadow"}: \text{new label} = \begin{cases} \text{"removed object"} & \text{if "new shadow" is connected to a "removed object"} \\ \text{"new shadow"} & \text{otherwise} \end{cases}$$

The application of the enhanced labeling scheme (Eq. 2) with its rules (Eq. 3) to solve the shadow ambiguity is shown for two range images (Fig. 7) which have been acquired with an ABW range finder working on the principle of space

coding with projected stripe pattern and triangulation¹². Fig. 8 shows the result of the first labeling step (Eq. 2) as labeled regions superposed onto the range image r_1 . The labels "unchanged" and "undefined" have been omitted for display convenience. Fig. 9 shows the final segmentation after the shadow relabeling according to Eq 3. Only the "new object" and "removed object" regions are drawn and now represent the correct zones where added or removed objects are lying.

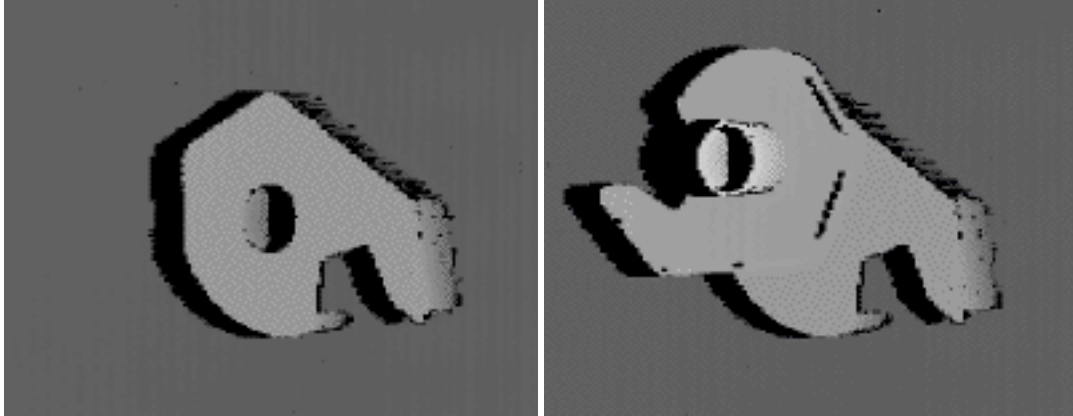

Fig. 7 Range images r_0 and r_1

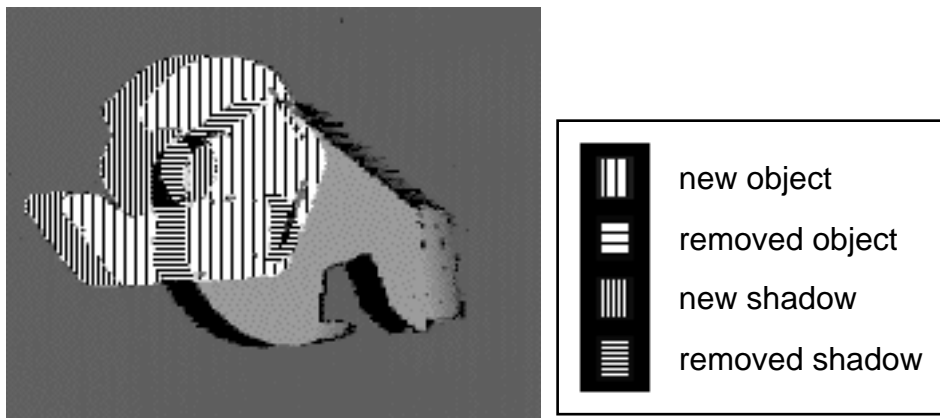

Fig. 8 First labeling step

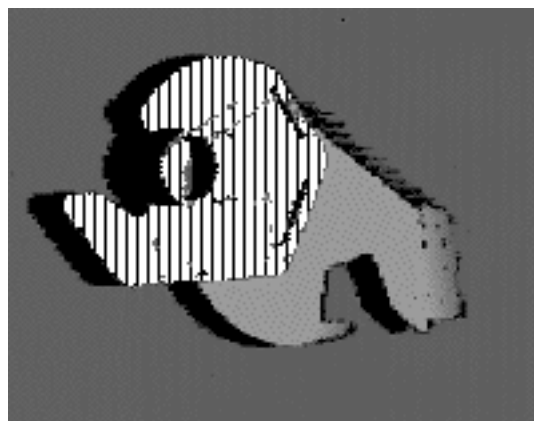

Fig. 9 Final segmentation after the second labeling step

An example of a removed object is simply obtained by flipping the order of the images in Fig. 7. The results of the two labeling steps are shown in Fig. 10. Notice the duality with the labeling of Fig. 8 and 9.

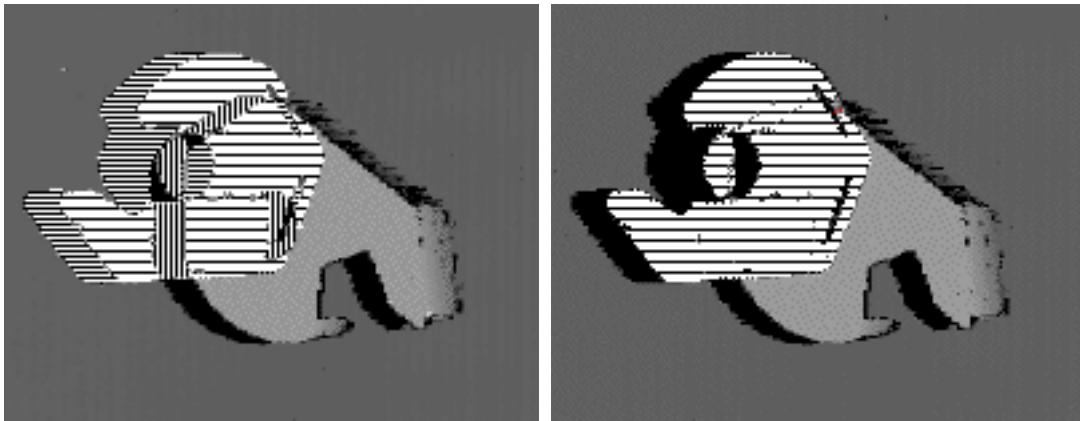

Fig. 10 Segmentation using the inverse order of the images in Fig. 7

The presented change detection method allows to detect added or removed objects of any form from two successive range images. The introduced shadow controlling helps to deal with range images containing non-valid pixels which makes the method applicable to a wide range of range finders.

More examples and also some limitations of the shadow controlling are shown in the next section.

4. APPLICATIONS

The presented range image segmentation algorithm based on change detection is part of our object recognition system^{5,9,10} and has been verified for several configurations. The range images are acquired with the ABW range finder. A typical scene and the successful object detection are shown in Fig. 11 where free-form objects are added and removed to/from a complex background.

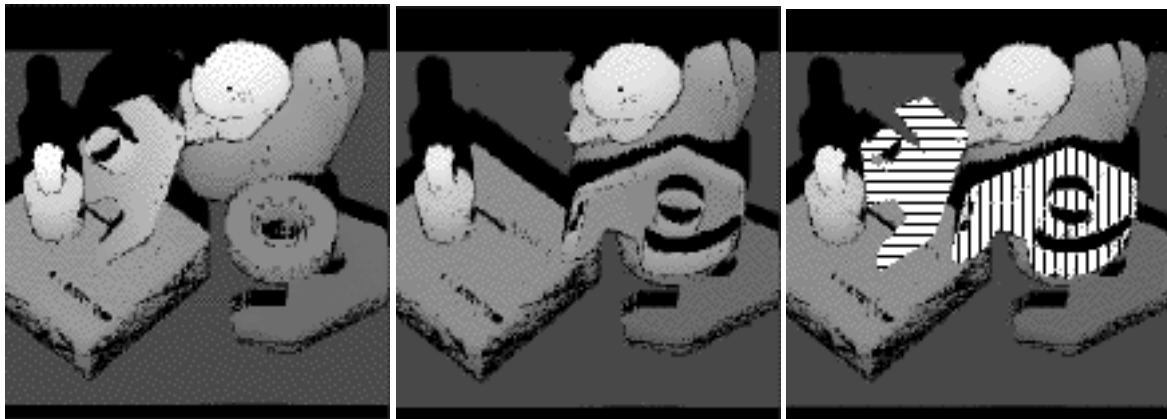

Fig. 11 Segmentation results for free-form objects on complex background

The presented change detection algorithm is also successfully used in a tape dispenser assembly system. It allows detection of objects which are grasped by a robot. The range images are obtained from the BIRIS range finder and contain significant noise. Here, a preceding gaussian filtering of the range images is necessary since the relative amount of noise is increased through subtraction⁸. Fig. 12 shows the segmentation of an added object occluding another one.

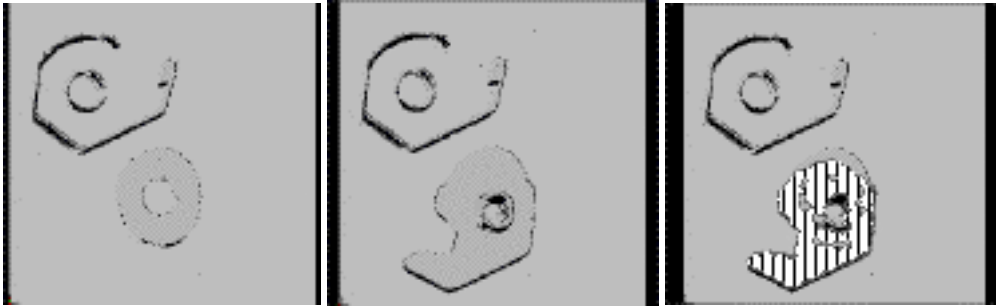

Fig. 12 Segmentation results for the BIRIS range finder

Finally, the example in Fig. 13 indicates some limitations of the proposed heuristic. If a shadow region is connected to both a "new object" and a "removed object" at the same time the mentioned shadow ambiguity is not solvable using the proposed rules in Eq 2 and 3. The "removed shadow" is added to the "new object" although it represents not a part of it.

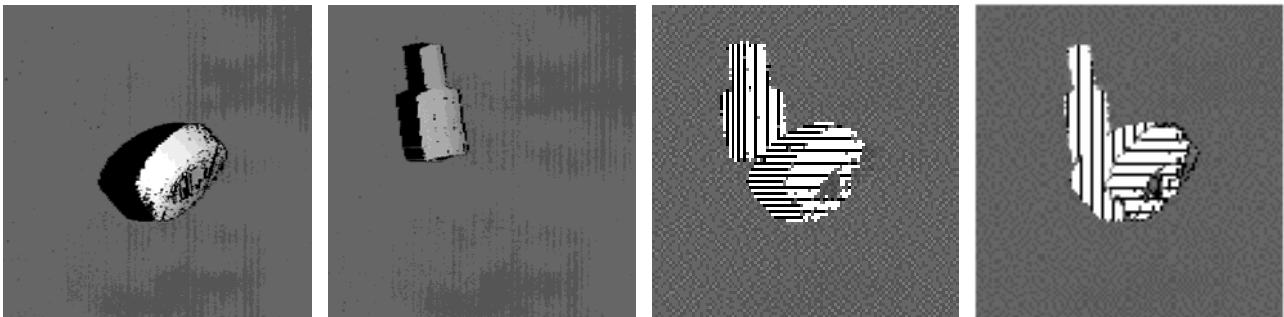

Fig. 13 Limitations of the shadow controlling

5. CONCLUSIONS

We proposed to extend the change detection method known in classical image processing for segmenting range images and presented a method to do so.

Since most range finders generate range images with missing values, a labeling scheme was introduced which permits the correct interpretation of the related values. Further rules based on connectivity allow a complete reconstruction of the object regions.

The change detection method allows to detect objects of any arbitrary concave and convex form. The method does not need object modeling or feature extraction. It leads to the possibility to segment a scene by isolating newly added or removed objects. The benefit is object separation and high rejection of the background, which are advantageous for the subsequent shape recognition.

The method was practically implemented. It was tested and run on two distinct range imagers of the light stripping type. We presented results that show the efficiency of this approach and the practical possibility to use it in the frame of an assembly task where vision is used to update the 3D model of the robot environment by detecting and recognizing new objects that enter the workspace, or old objects that are removed.

Future work will assess some of the limitations occurring with the shadow ambiguity and not solved yet by the defined rules.

6. ACKNOWLEDGMENTS

This research has been funded by the Swiss national Priority Program in Informatics, Knowledge-based systems, under project number 5003-344336.

7. REFERENCES

Literature:

1. P. Besl and N. McKay. "A method for registration of 3-D shapes," *IEEE Transactions On Pattern Analysis and Machine Intelligence*, Vol. 14, No. 2, pp. 239-256, 1992.
2. W. Frei, M. Singh & T. Shibata. "Digital Image Change Detection", *SPIE Optical Engineering*, Vol. 19, Nr. 3, pp. 331-338, 1980.
3. P. Gingins and H. Hugli. "Model-based 3D object recognition by a hybrid hypothesis generation and verification approach," *Intelligent Robots and Computer Vision XIII: Algorithms and Computer Vision*, Boston, SPIE 2353, pp. 67-77, 1994.
4. M. Hebert, J. Ponce, T. E. Boulton, A. Gross and D. Forsyth. "Representation for computer vision," *Report of the NSF/ARPA workshop on 3D object*, CUNY Graduate School and University Center, 1994.
5. H. Hugli, Ch. Schutz, D. Semitekos. "Geometric matching for free-form 3D object recognition," *ACCV 95*, Singapore, Vol 3, pp. 819-823, 1995.
6. R. C. Jain & A.K. Jain. *Analysis and Interpretation of Range Images*, Springer Verlag, New York, 1990.
7. R. Milanese. *Detecting Salient Regions in an Image: from Biological Evidence to Computer Implementation*, Thesis No. 2647, Dept. of Computer Science, University of Geneva, Switzerland, December 1993.
8. J. C. Russ. *The Image Processing Handbook*, CRC Press, pp. 272-274, 1995.
9. Ch. Schutz and H. Hugli. "Recognition of 3-D objects with a closest point matching algorithm," *From Pixels to Sequences*, Proc. conf. ISPRS, Zurich, Vol. 30, pp. 128-133, 1995.
10. Ch. Schutz, H. Hugli. "Towards the recognition of 3D free-form objects", *SPIE Int. Symposium on Intelligent Robots and Advanced Manufacturing, Intelligent Robots and Computer Vision XIV*, Philadelphia, Vol. 2588, pp. 476-484, 1995.

Range finders:

11. VITANA Corp., 24-5470 Canotek Road, Gloucester, Ontario, K1J 9H3, Canada.
12. ABW, Gutenbergstrasse 9, D-72636 Frickenhausen, Germany.