

Free-running 9.1- μm distributed-feedback quantum cascade laser linewidth measurement by heterodyning with a C^{18}O_2 laser

D. Weidmann, L. Joly, V. Parpillon, and D. Courtois

Groupe de Spectroscopie Moléculaire et Atmosphérique, Faculté des Sciences, Université de Reims Champagne—Ardenne, B.P. 1039, 51687 Reims Cedex 2, France

Y. Bonetti

Alpes Lasers SA, Passage Max Meuron 1-3, 2001, Neuchâtel, Switzerland

T. Aellen, M. Beck, J. Faist, and D. Hofstetter

Institut de Physique, Université de Neuchâtel, Rue A. L. Bréguet 1, 2000 Neuchâtel, Switzerland

We report spectral linewidth measurements of a 9.1- μm distributed-feedback quantum cascade laser (QCL). The free-running QCL beam was mixed with a waveguide isotopic C^{18}O_2 laser onto a high-speed HgCdTe photomixer, and beat notes were recorded from a radio-frequency spectral analyzer. Beating was performed at two operating conditions, first near the QCL laser threshold (beating with the C^{18}O_2 R10 line) and then at a high injection current (beating with the C^{18}O_2 R8 line). Overall, beat note widths of 1.3–6.5 MHz were observed, which proves that a free-running QCL can have a short-term spectral width near 1 MHz.

OCIS codes: 140.3070, 140.3490, 140.3600, 140.5960, 120.5050, 120.4820.

Quantum cascade lasers¹ (QCLs) are tunable medium-IR laser sources that are widely used. Either for free-space optical communications² or for high-resolution spectroscopy,³ cw operation and low spectral width are key parameters. A cw narrow linewidth yields either a high transmitted data rate or high spectral resolution. Using a QCL in pulse mode causes a thermal chirp, which degrades spectral purity. Several authors have reported spectral width measurements of frequency-stabilized⁴ and free-running QCLs.^{5,6} To the best of our knowledge, we report in this Letter the first direct observation of a 9.1- μm distributed-feedback QCL spectral width by heterodyning with a cw C^{18}O_2 laser. This QCL wavelength is particularly attractive because it hits the 8–13- μm atmospheric window.

The QCL is housed inside a laboratory-built cryostat filled with liquid nitrogen.⁷ The temperature is monitored and stabilized by a digital controller (Lakeshore 340). Its long-term (several seconds) temperature stability is ± 0.02 K, but its short-term stability (less than 1 s) is better. However, its behavior was found to be variable and unpredictable. The current is supplied to the QCL by a linearly stabilized dc power supply (Lambda LQD-421-W), with an additional 10- Ω serial resistance. To reduce current fluctuations we added a RC low-pass filter with a 30-Hz cutoff frequency at the supply's output. The QCL then reached a long-term stability of ± 16 μA at 0.6A. We shall see below that these two kinds of instability induce additional frequency drifts in the QCL. The QCL beam is collected and shaped by ZnSe lenses. Then, a C^{18}O_2 laser beam (Model C7,

SAT-France) is superimposed upon it by a ZnSe beam splitter ($T = R = 50\%$), where T means transmittance and R means reflectance. The beam waists of the two lasers are conjugated by a mixing plate. The two beams are mixed onto a high-speed HgCdTe photodiode (SAT-France; >1500-MHz bandwidth). We took care to avoid optical feedback in the QCL by making a slight misalignment. Figure 1 gives experimental details of the optical setup.

For coarse evaluation of QCL wavelength we used an Ebert–Fastie grating spectrometer with a 300-mm focal length and a 150-line/mm grating. The resolution was 0.1 cm^{-1} , with slits opened at 0.2 mm.

We used direct absorption spectroscopy of SO_2 to calibrate the QCL wavelength finely relative to

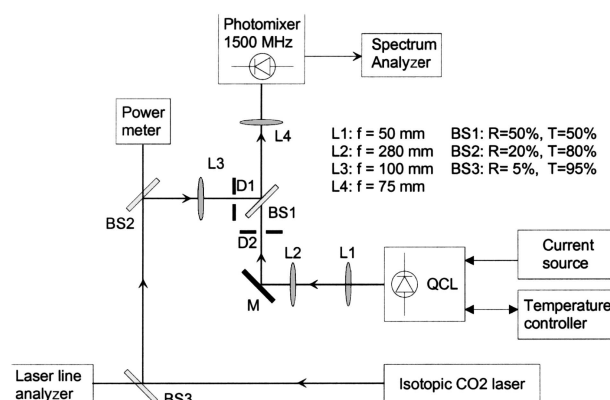

Fig. 1. Schematic of the optical setup for the beating experiment: BS1–BS3, beam splitters; L1–L3, lenses; D1, D2, beam waists; M, mirror.

temperature and current. ν_1 band SO_2 absorption lines gave us an absolute frequency reference. The 20-cm-long gas cell was filled with 10 Torr of SO_2 . A high-finesse confocal etalon provided a 0.01-cm^{-1} relative frequency reference. We determined the tunable range of the laser: From 1091.04 cm^{-1} at $T = 86\text{ K}$ and $I = 0.45\text{ A}$ to 1087.28 cm^{-1} at $T = 120\text{ K}$ and $I = 0.97\text{ A}$, it operates single mode over the entire range. The laser threshold is 0.43 A at 80 K . It can emit as much as 38 mW of optical power at $I = 0.85\text{ A}$ and $T = 80\text{ K}$. In addition, we thus deduced the current-tuning rate, $-2.5\text{ cm}^{-1}/\text{A}$, and the temperature-tuning rate, $-0.064\text{ cm}^{-1}/\text{K}$ near threshold to $-0.075\text{ cm}^{-1}/\text{K}$ at high injection current.

The isotopic C^{18}O_2 laser is cooled to 10°C by an alcohol circuit. At this temperature, rather weak transitions of the $^{18}\text{O}^{12}\text{C}^{18}\text{O}$ II-band R branch can be reached. We performed the beating experiment with the laser working at $1089.74096\text{ cm}^{-1}$ ($R8$ line) and $1091.02466\text{ cm}^{-1}$ ($R10$).⁸ The optical power emitted is $\sim 11\text{ mW}$ for lasing on the $R8$ line and 31 mW for lasing on the $R10$ line. The laser is sealed off and contains 50 Torr of gas. It is actively stabilized by an optogalvanic method; the stability reached during 1 s is 1 MHz .

Both the C^{18}O_2 laser and the QCL optical powers were reduced by use of iris diaphragms D1 and D2 (Fig. 1). The HgCdTe photodiode operates at reverse bias. The photocurrent is fed into a radio-frequency spectrum analyzer (Model IFR-2398). During the beating the QCL and the C^{18}O_2 laser operate at a fixed frequency, and beat notes are then recorded by a PC.

Figure 2 shows beat notes obtained with the C^{18}O_2 laser $R10$ line under identical experimental conditions. At this frequency the QCL operates at $I = 0.47\text{ A}$ and $T = 86.3\text{ K}$, viz., very near threshold ($I_{\text{th}} = 0.46\text{ A}$). It emits $400\text{ }\mu\text{W}$ of optical power. As one can see from the figure, the frequency difference between the two lasers is 512 MHz .

By recording several successive single shots with a spectrum analyzer with a resolution bandwidth of 30 kHz and a 0.5-s sweep time, we observed that the beat note's linewidth varies from 1.3 to 5 MHz . In accordance with the established long-term stability and current-tuning rate, the QCL spectral linewidth should always be below 2.2 MHz . We believe that the linewidth variations from one shot to another are directly linked to unpredictable short-term temperature stability. At this operating point the best-fitting peak function was found to be Gaussian. One can argue that the low-frequency phase noise caused by both temperature and current instabilities is the main noise source.⁹ In Fig. 2(a) the C^{18}O_2 spectral contribution to the beating width is no longer insignificant. If we consider Gaussian laser profiles, the resultant QCL spectral width is near 1 MHz .

Figure 3 shows two new beat notes, but this time the QCL operates at a high injection current, viz., 0.85 A , with $T = 91\text{ K}$, emitting $\sim 20\text{ mW}$ of optical power. The C^{18}O_2 laser cavity and grating were adjusted to reach emission at the $R8$ line frequency. The frequency difference between the two lasers

is 1205 MHz . Again, under identical experimental conditions, the observed linewidth varies from one shot to another, from 2.8 to 6.5 MHz . This time the best fitting function is a Lorentzian, though the QCL is far from operating under the quantum noise limit. Low-frequency phase noise is no longer the main one.

We believe that a comparison of the QCL with other tunable laser sources operating in the same spectral region could be of interest. Near $9.1\text{ }\mu\text{m}$, only lead salt diode lasers are available. Except at specific measurements that achieve quantum noise limited width,¹⁰ diode laser linewidths are often found to be greater than 10 MHz .^{11,12} Unlike diode lasers, QCLs, have a linewidth enhancement parameter α (Ref. 13) that is near zero.¹ In addition, current- and temperature-tuning rates are more than 10 times lower for QCLs. Therefore QCLs are less sensitive to current and temperature fluctuations than are lead salt lasers. In addition, the QCL's optical power is 100 times greater than a lead salt laser's power.

In conclusion, we have measured a cw $9.1\text{-}\mu\text{m}$ QCL linewidth in a heterodyne experiment. These results demonstrate that, even with an almost standard power supply and medium temperature stability, linewidths of $1\text{--}6\text{ MHz}$ can easily be obtained. These narrow widths are a new advantageous feature of QCLs in addition to high power and single-mode emission.

The limitation observed here is due to technical noise produced by current and temperature

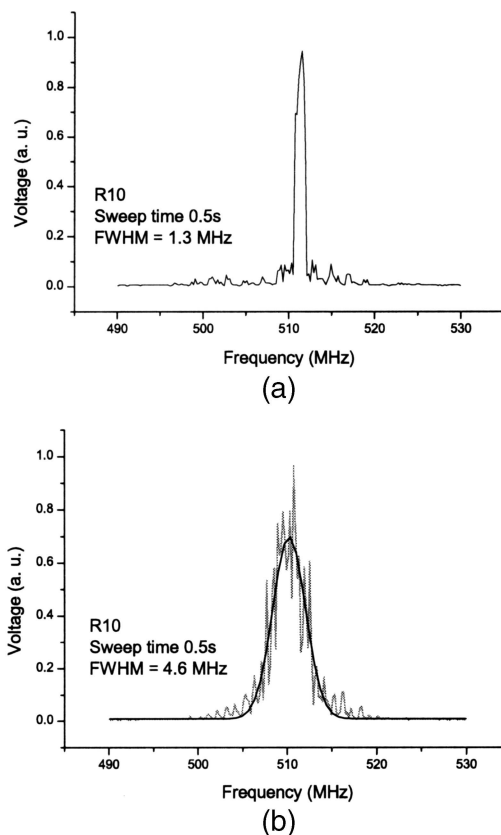

Fig. 2. Beat notes of the QCL operating at 0.47 A and 86.3 K and of the isotopic C^{18}O_2 laser lasing on the $R10$ line. (a) Low and (b) high linewidth limits observed under identical experimental conditions.

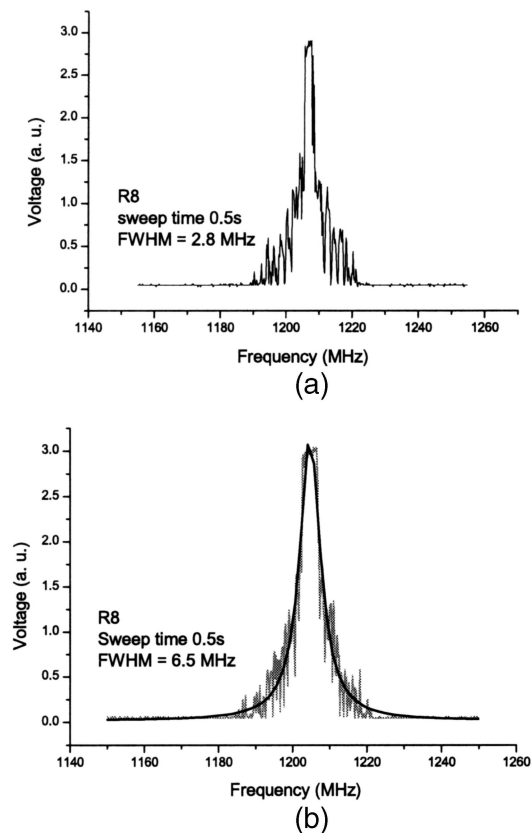

Fig. 3. Beat notes of the QCL operating at 0.85 A and 91 K and of the isotopic $C^{18}O_2$ laser lasing on the R8 line under the same experimental conditions as for Fig. 2.

instabilities and is not a QCL limitation. We are now working to solve this technical problem. A goal for the future is to actively stabilize the QCL frequency on a molecular line or on a high-finesse etalon fringe to achieve a narrower QCL spectral width.

The authors thank D. Décatore, F. Polak, X. Thomas, and P. Von Der Heyden of the Groupe de

Spectroscopie Moléculaire et Atmosphérique Laboratory, Université de Reims, for technical assistance. D. Weidmann's e-mail address is damien.weidmann@univ-reims.fr.

References

1. J. Faist, F. Capasso, D. L. Sivco, C. Sirtori, A. L. Hutchinson, and A. Y. Cho, *Science* **264**, 553 (1994).
2. R. Martini, C. Bethea, F. Capasso, C. Gmachl, R. Paiella, E. A. Whittaker, H. Y. Hwang, D. L. Sivco, J. N. Baillargeon, and A. Y. Cho, *Electron. Lett.* **38**, 181 (2002).
3. A. A. Kosterev, R. F. Curl, F. K. Tittel, C. Gmachl, F. Capasso, D. L. Sivco, J. N. Baillargeon, A. L. Hutchinson, and A. Y. Cho, *Appl. Opt.* **39**, 4425 (2000).
4. R. M. Williams, J. F. Kelly, J. S. Hartman, S. W. Sharpe, M. S. Taubman, J. L. Hall, F. Capasso, C. Gmachl, D. L. Sivco, J. N. Baillargeon, and A. Y. Cho, *Opt. Lett.* **24**, 1844 (1999).
5. S. W. Sharpe, J. F. Kelly, J. S. Hartman, C. Gmachl, F. Capasso, D. L. Sivco, J. N. Baillargeon, and A. Y. Cho, *Opt. Lett.* **23**, 1396 (1998).
6. H. Ganser, B. Frech, A. Jentsch, M. Mürztz, C. Gmachl, F. Capasso, D. L. Sivco, J. N. Baillargeon, A. L. Hutchinson, A. Y. Cho, and W. Urban, *Opt. Commun.* **197**, 127 (2001).
7. D. Weidmann and D. Courtois, *Infrared Phys. Technol.* **41**, 361 (2000).
8. C. Freed, L. C. Bradley, and R. G. O'Donnell, *IEEE J. Quantum Electron.* **QE-16**, 1195 (1980).
9. D. S. Elliott, R. Roy, and S. J. Smith, *Phys. Rev. A* **26**, 12 (1982).
10. E. D. Hinkley and C. Freed, *Phys. Rev. Lett.* **23**, 277 (1969).
11. J. Reid, D. T. Cassidy, and R. T. Menzies, *Appl. Opt.* **21**, 3961 (1982).
12. R. Brunner and M. Tacke, *Infrared Phys. Technol.* **43**, 61 (2002).
13. C. H. Henry, *IEEE J. Quantum Electron.* **18**, 259 (1982).